



Part # 11371010

1988-1998 GM C1500 CoolRide AirSpring Kit with HQ Series Shocks



Recommended Tools



1988-1998 GM C1500 CoolRide AirSpring Kit Installation Instructions

Table of contents	
Page 2.....	CoolRide Kit Components
Page 3.....	Hardware List & Getting Started
Page 4.....	Installing Shock Bracket & Assembling CoolRide
Page 5.....	Installing CoolRide
Page 6.....	Shock Adjustment

THIS COOLRIDE KIT IS DESIGNED TO BE USED WITH STOCK 88-98 C1500 CONTROL.

THE SHOCK BRACKETS IN THIS KIT NEED TO BE INSTALLED BEFORE THE AIRSPRINGS!



CoolRide Kit ComponentsIn the box

Item #	Part Number	Description	QTY
1	90000024	Upper Air Spring Cup Bracket	2
2	90006873	8" Diameter AirSpring	2
3	90000057	Lower Air Spring Cup Bracket	2
4	986-10-035	3.85" HQ Series Shock Assembly	2
5	90001341	Shock Mount - Driver	1
5	90001342	Shock Mount - Passenger	1
6	70011138	3/4" ID Shock Bushing	4
7	90000549	1/2" ID x 2" Shock Sleeve	2
8	90002103	5/8" ID x 1.312" Shock Sleeve	2
9	90001619 KIT	Cantilever PIN 1/2"-2- X 3" Bolt	2
10	90001619 KIT	Cantilever Pin Bolt Spacer	2
11	9000169 KIT	1/2" Flat Washer	2
12	90001619 KIT	1/2"-20 N Nylok Nut	2

Driver Side Shock Bracket Shown

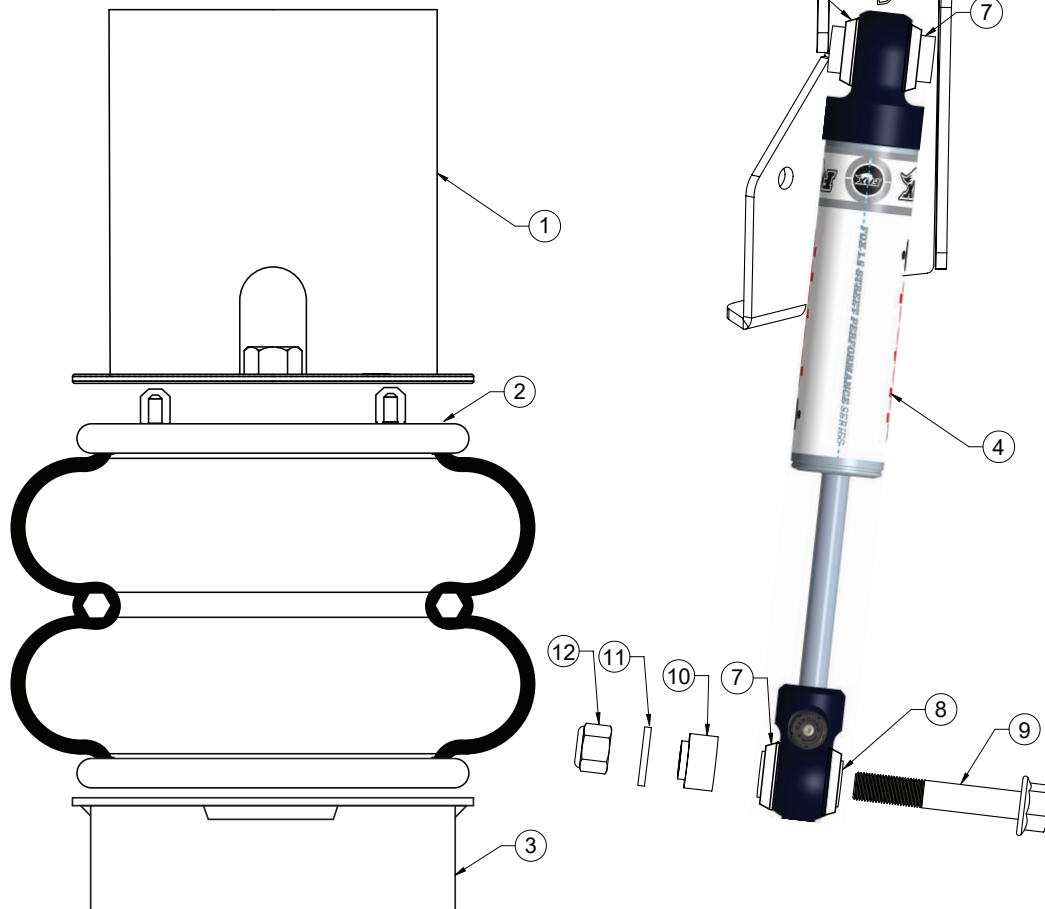



CoolRide Hardware Kit #99010093.....In the box

QTY	Part Number	Description	QTY	Part Number	Description
UPPER AIRSPRING MOUNTING			LOWER AIRSPRING MOUNTING		
2	99435002	7/16" -14 x 8" Stud	2	99371001	3/8" -16 X 3/4" Hex Bolt
2	99432001	7/16" -14 Nylok Nut	2	99373005	3/8" Split Lock Washer
2	99433002	7/16" Flat Washer	2	99373003	3/8" SAE Flat Washer
4	99372002	3/8" -16 Nylok Nut			
4	99373003	SAE Flat Washer			

Shock Kit Hardware Kit #99010094.....In the box

QTY	Part Number	Description	QTY	Part Number	Description
UPPER SHOCK MOUNTING			SHOCK MOUNT TO FRAME		
2	99501005	1/2" -13 x 3 1/2" Hex Bolt	6	99371004	3/8" -16 X 1 1/4" Hex Bolt
2	99502009	1/2" -13 Nylok Nut	6	99372002	3/8" -16 Nylok Nut
4	99503014	1/2" SAE Flat Washer	12	99373003	3/8" SAE Flat Washer

Getting Started.....

1. Remove the OEM coil springs from the truck. Refer to a Factory Service Manual for the proper method. Leave the lower control arm disconnected from the spindle until the air springs are installed.

THE SHOCK MOUNT WILL NEED TO BE INSTALLED BEFORE INSTALLING THE AIR SPRINGS. YOU NEED TO BE ABLE TO ACCESS THE INSIDE OF THE FRAME THROUGH THE COILSPRING POCKET.

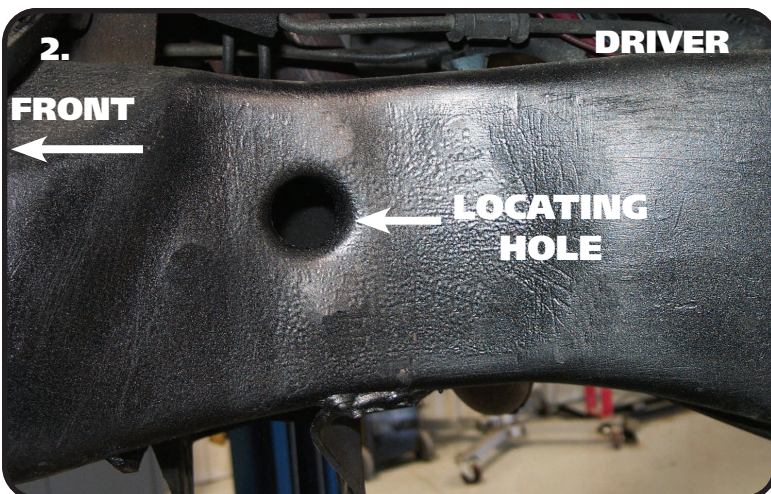

2. Use Images 2 & 3 for installation of the Shock Brackets. DRIVER SIDE IS SHOWN IN THE IMAGES. The Shock Brackets locate off the bottom of the frame rail and the LARGE HOLE that is located to the rear of the coil spring pocket.



Installing Shock Bracket & Assembling CoolRide

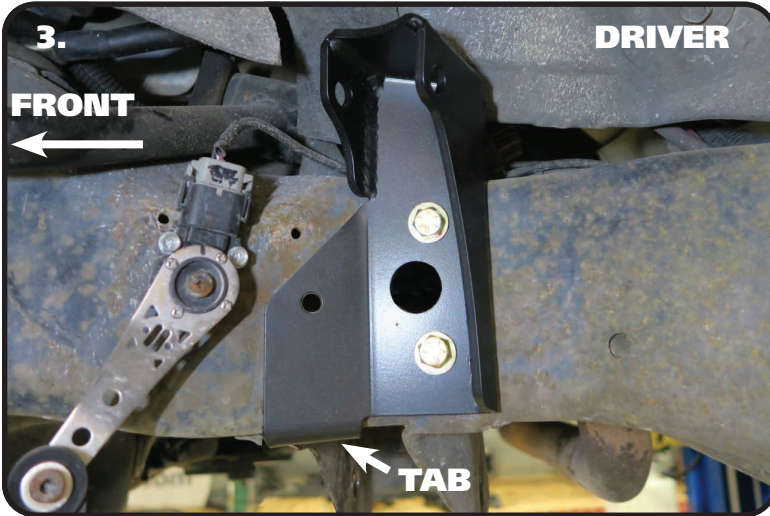

3. Hold the DRIVER Shock Bracket on the frame rail with the LOWER TAB AGAINST THE BOTTOM OF THE FRAME AND LOCATING HOLE ALIGNED WITH THE HOLE IN THE FRAME. Using the bracket as a template, mark the holes and drill with a 3/8" drill bit. Install a 3/8" flat washer on each of (3) 3/8"-16 x 1 1/4" hex bolts. Insert the bolt/washers through the bracket and frame. Install a 3/8" flat washer and 3/8"-16 nylok nut on the threads of each of the bolts sticking through the frame. You will have to reach in the coil spring pocket to install the washers and nuts. Torque the hardware to 35 ftlbs. Repeat for the passenger side.



4. Insert the SHOCK BODY end of the shock into the shock bracket. Align the through hole with the 1/2" holes in the shock bracket. Install a 1/2" flat washer on a 1/2"-13 x 3 1/2" hex bolt. Insert the bolt/washer through the aligned holes. Install a 1/2" flat washer & 1/2"-13 nylok nut on the threads that are sticking through the bracket. Torque the bolt/nut to 75 ftlbs.

THE SHOCK BRACKETS NEED TO BE INSTALLED BEFORE THE AIRSPRINGS!



5. Apply thread sealant to the air fitting and screw it into the air spring. Assemble the upper cup bracket to the air spring, using 3/8"-16 Nylok nuts and 3/8" flat washers. Bolt the lower cup to the bottom of the air spring using a 3/8" x 3/4" bolt, flat washer and lock washer. Torque the 3/8" hardware 15-20 ftlbs. Thread the 8" stud into nut welded to the bottom of the cup bracket.



Installing CoolRide



6. Place the assembly up into the upper coil spring pocket; the stud will go through the factory shock hole. Fasten with a 7/16"-14 Nylok nut and 7/16" flat washer. Tighten the nut enough to hold the airspring/cup solidly in place. Reattach the lower arm to the spindle. The lower cup is not attached to the lower arm; it will simply sit in the coil spring pocket.

Note: The airline must also be routed at this time.

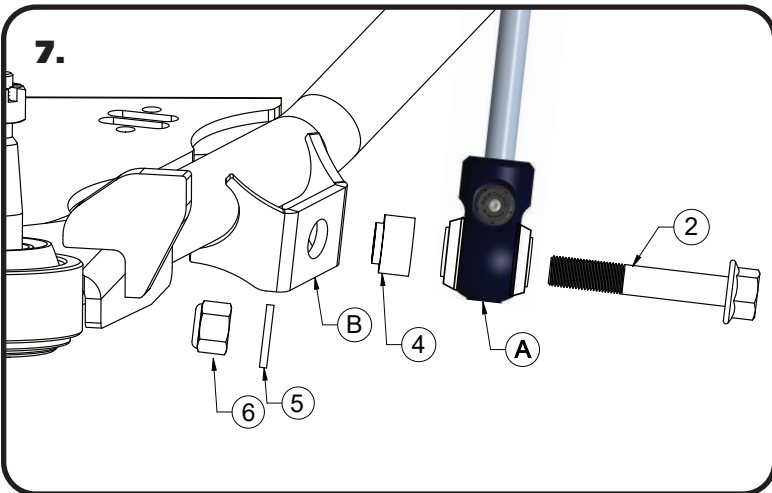

7. Drill a 5/8" hole in the rear leg of the lower control arm approximately 8 1/2" from the mounting bolt. This can be moved slightly to achieve maximum tire clearance. Check tire clearance lock to lock. Attach the shock(A) to the lower control arm(B). Attach the shock(A) to the lower control arm(B). Insert the 1/2"-20 x 3" flanged head bolt(2) through the bushing sleeve. Install the aluminum T-spacer(4) on the threads of the shock bolt with the SMALL OD toward the control arm. Insert the shock bolt/shock through the holes in the control arm shock mount. Install the flat washer(5) on the threads, followed by the 1/2"-20 nylok nut(6). Torque the nut to 75 ftlbs.

8. The final step is to have the vehicle realigned. You will want to have this done at ride height. Ride height is determined by air spring height. This spring should be approximately 4 3/4"-5" tall, which should occur around 90-105 psi. This will vary to driver preference and vehicle weight.



Shock Adjustment

Shock adjustment 101- Single Adjustable

Rebound Adjustment:

How to adjust your new shocks.

The rebound adjustment knob is located on the top of the shock absorber protruding from the eyelet.

You must first begin at the ZERO setting, then set the shock to a soft setting of 20.



-Begin with the shocks adjusted to the ZERO rebound position (full stiff). Do this by rotating the rebound adjuster knob clockwise until it stops.



-Now turn the rebound adjuster knob counter clock wise 20 clicks. This sets the shock at 20. (settings 21-24 are typically too soft for street use).

Take the vehicle for a test drive.



-if you are satisfied with the ride quality, do not do anything, you are set!

-if the ride quality is too soft increase the damping effect by rotating the rebound knob clock wise 3 clicks.

Take the vehicle for another test drive.



-if the vehicle is too soft increase the damping effect by rotating the rebound knob clock wise 3 additional clicks.



-If the vehicle is too stiff rotate the rebound adjustment knob counter clock wise 2 clicks and you are set!

Take the vehicle for another test drive and repeat the above steps until the ride quality is satisfactory.

Note:

One end of the vehicle will likely reach the desired setting before the other end. If this happens stop adjusting the satisfied end and keep adjusting the unsatisfied end until the overall ride quality is satisfactory.