

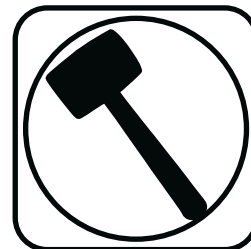

### Part # 12099599 - 1964-1966 Ford Mustang Front TruTurn System

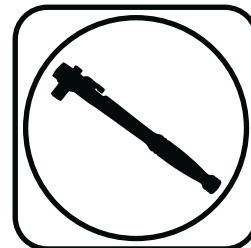

#### Recommended Tools



## 1966-1966 Ford Mustang TruTurn System Installation Instructions

### Table of contents

Page 2.....	Major Components
Page 3.....	Upper Control Arm Components
Page 4.....	Lower Control Arm Components
Page 5.....	TruTurn Steering Components
Page 6.....	Hardware & Getting Started
Page 7.....	Installing Strut Rod Adapter
Page 8-10.....	Installing Control Arms
Page 10.....	Spindle Installation
Page 11-12.....	Centerlink Adapter Installation
Page 13.....	Steering Arm & Stop Installation
Page 14-15.....	Tie-Rod Assembly and Installation
Page 16-17.....	Crossmember Brace Installation

Mini-Starter required to clear TruTurn Centerlink Adapter (not Included).

The OEM Front Brakes will not work with this kit. (See Page 6 for details)



### Major Components Assembled .....In the box

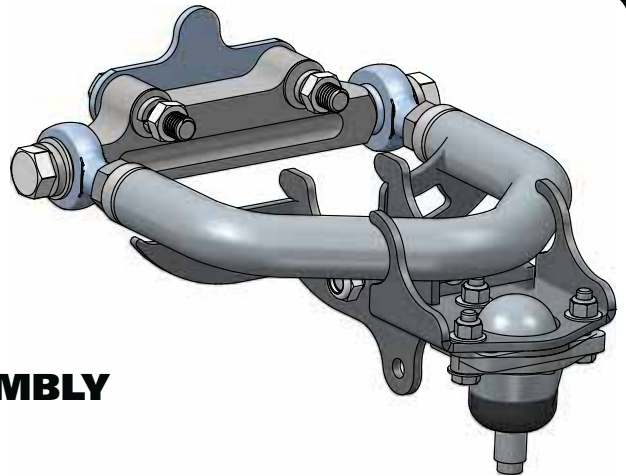

#### **DRIVER UPPER CONTROL ARM ASSEMBLY**

Exploded View on Page 3

#### **DRIVER LOWER CONTROL ARM ASSEMBLY**

Exploded View on Page 4

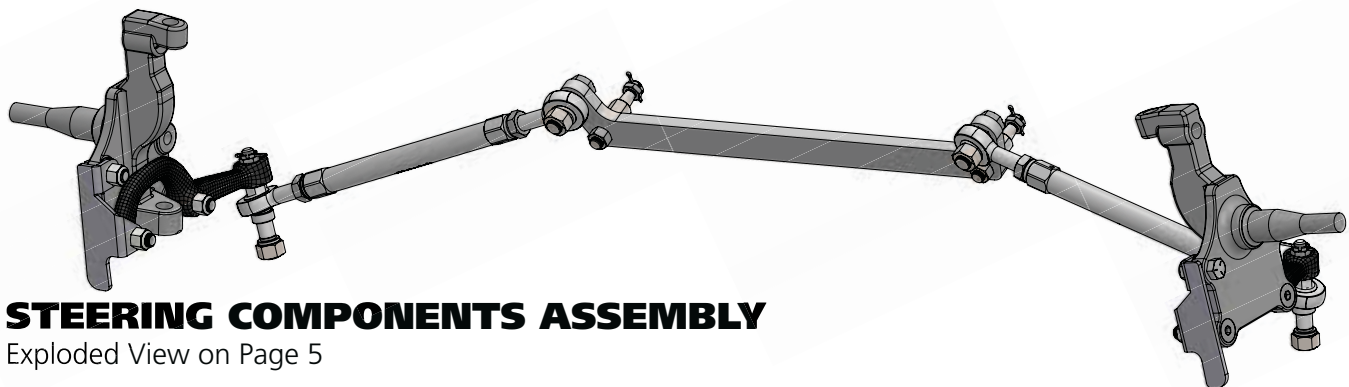
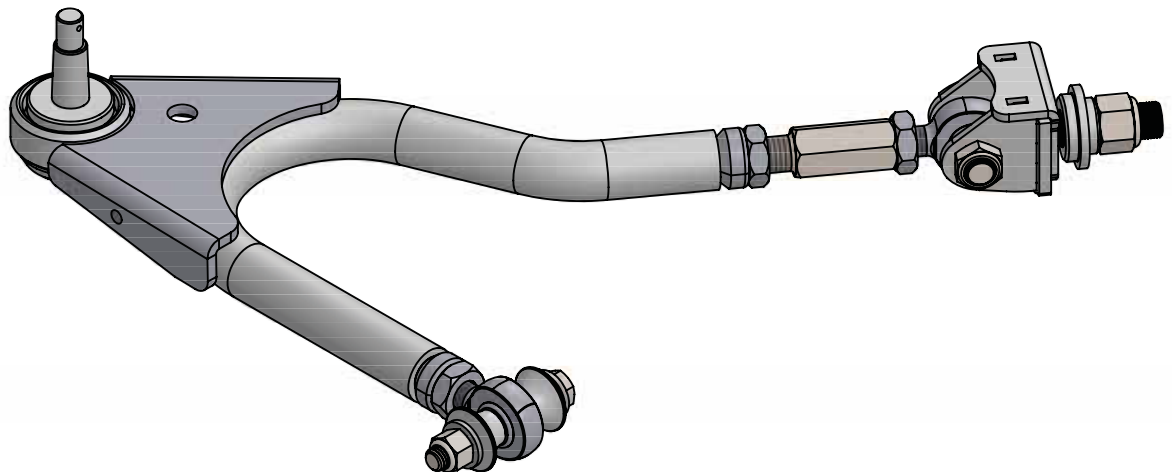

#### **STEERING COMPONENTS ASSEMBLY**

Exploded View on Page 5





### Lower Control Arm Components .....In the box

Item #	Part Number	Description	QTY
20	90003221	Driver Lower Control Arm <b>(Shown)</b>	1
21	90003222	Passenger Lower Control Arm	1
22	90003223	Strut Rod Frame Bracket Assembly	2
23	90003228	Frame T-Bushing	2
24	90001589	3/4" -16 x 5/8" Bolt Heim End - RH	2
25	90001591	3/4" -16 x 5/8" Bolt Heim End - LH	2
26	99752004	3/4" -16 Jam Nut - RH	4
27	99752006	3/4" -16 Jam Nut - LH	2
28	90002338	Frame Heim Spacer - 1/2" ID x 1.00" Long	4
29	90003225	Strut Rod Bracket Heim Spacer - 5/8" ID x .320" Long	4
30	90002582	Heim End Double Adjuster	2
31	90000898	Lower Ball joint - Proforged # 101-10013	2

Driver Side Shown

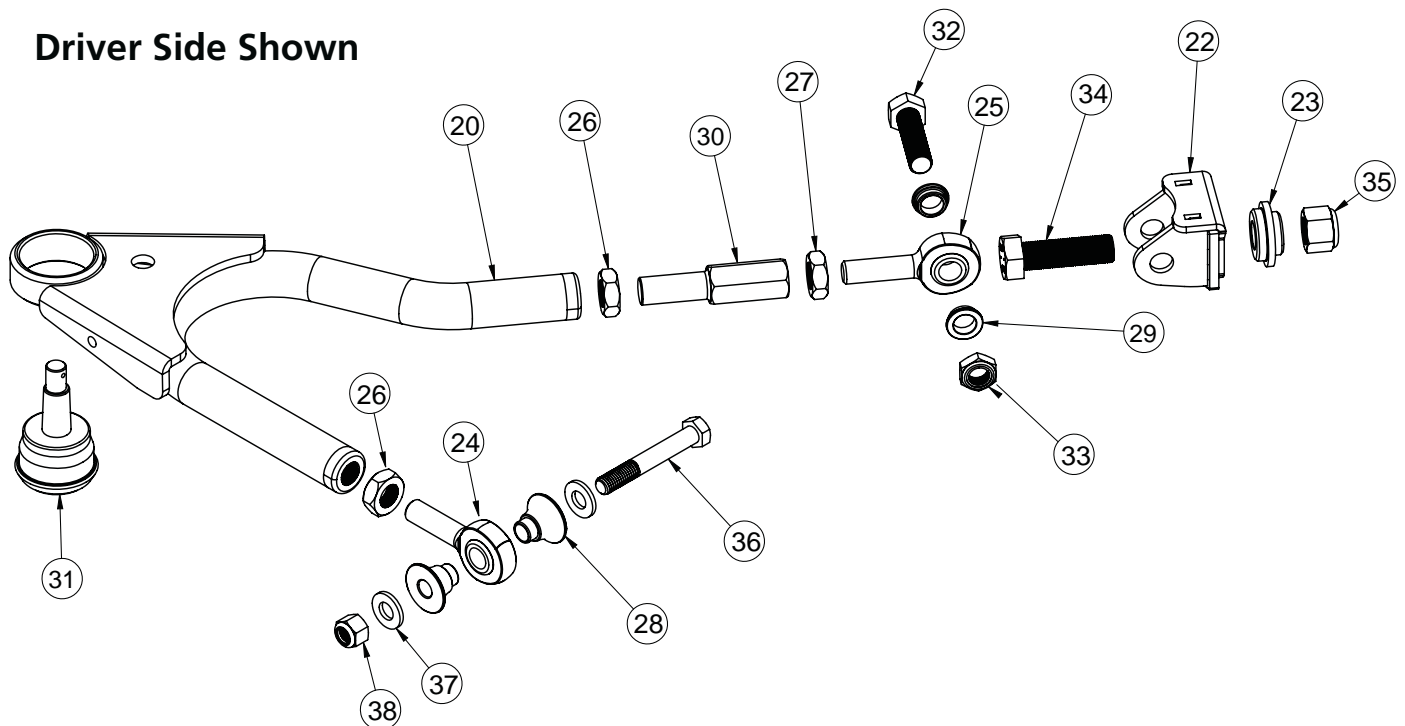



### TruTurn Steering Components ....In the box

Item #	Part Number	Description	QTY
39	11009303	Ridetech Tall Spindle	1 pr
40	90002345	Drag Link Stud	2
41	90002351	Inner Tie Rod Stud	2
42	90002346	Tie-Rod Adjuster	2
43	90002347	Driver Steering Arm	1
44	90002348	Passenger Steering Arm	1
45	90002349	Bolt On Steering Stop - Driver	1
46	90002350	Bolt On Steering Stop - Passenger	1
47	90001582	Heim End - 5/8"-18 x 5/8" Bolt - RH Thread	2
48	90001590	Heim End - 5/8"-18 x 5/8" Bolt - LH Thread	2
49	90009931	Outer Tie Rod Stud	2
50	90002344	Centerlink Adapter	1

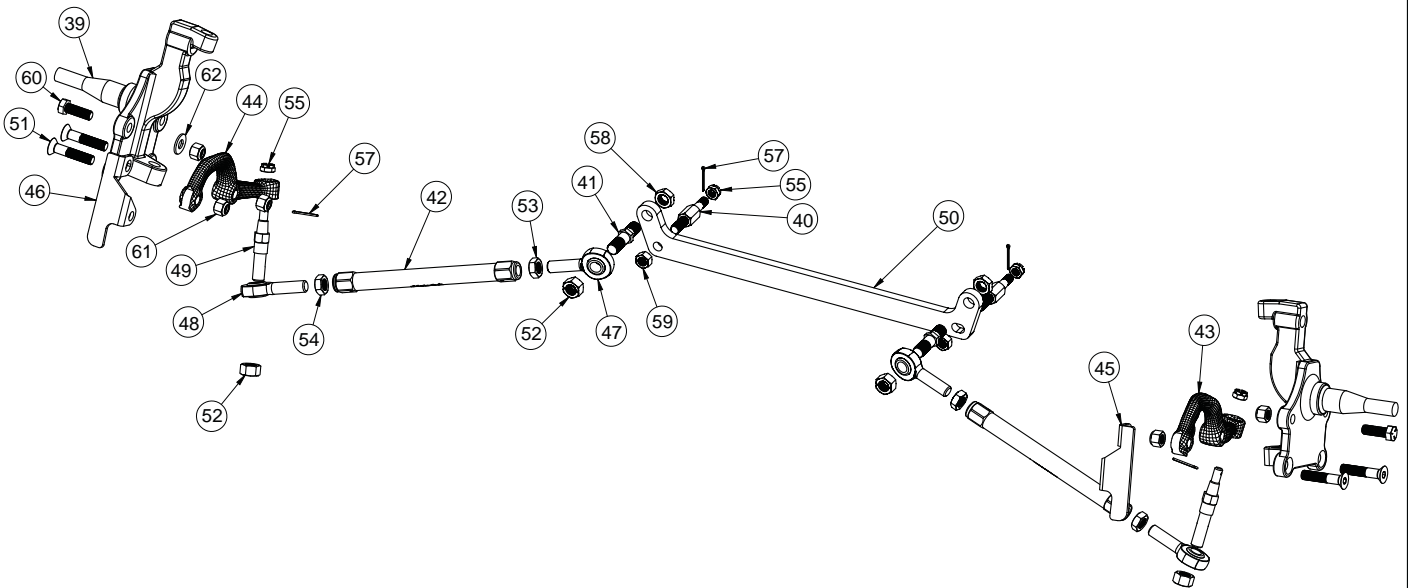



### Hardware Shown in Diagrams ....Kit# 99010164

Shock To Upper Control Arm				Spindle To Steering Arm			
ITEM #			QTY	ITEM #			QTY
14	99501005	1/2"-13 x 3 1/2" bolt GR8	2	51	99501054	1/2-20 X 2 1/2" Flat Head Socket Cap Screw	2
15	99502009	1/2"-13 Nylok Nut GR8	2	<b>Steering Linkage</b>			
16	99503014	1/2" SAE Flat Washer GR8	4	52	99622003	5/8"-18 TOP LOCK NUT	4
<b>Upper Control Arm To Car</b>				53	99800003	5/8"-18 RH Jam Nut	2
16	99503014	1/2" SAE Flat Washer GR8	8	54	99800002	5/8"-18 LH Jam Nut	2
17	99501050	1/2"-13 x 2 1/2" bolt GR8	4	55	99432005	7/16"-20 Castle Nut	2
18	99503015	1/2" SPLIT LOCK WASHER, GR8	4	56	99433002	7/16" SAE Flat Washer	2
19	99502021	1/2"-13 HEX Nut GR8	4	57	99952002	3/32" Cotter Pin	2
<b>Upper Ball Joint To Spindle</b>				<b>Draglink Adapter</b>			
	99502017	1/2"-20 Castle Nut	2	55	99432005	7/16"-20 Castle Nut	2
<b>Heim End Coupler</b>				56	99433002	7/16" SAE Flat Washer	4
26	99752004	3/4-16 Jam Nut	2	57	99952002	3/32" Cotter Pin	2
27	99752006	3/4-16 LH Jam Nut	2	58	99622005	5/8"-18 THIN mechanical locking nut	2
<b>Heim End To Strut Rod Frame Bracket</b>				59	99502010	1/2"-20 Mechanical Locking Nut	2
32	99621031	5/8-18 X 2 1/4" Hex Bolt Gr8	2	<b>Steering Stop</b>			
33	99622006	5/8-18 Thin Nylok Nut	2	60	99501053	1/2"-13 x 1 1/2" Hex Bolt GR8	2
<b>Strut Rod Frame Bracket To Car</b>				61	99502009	1/2"-13 Nylok Nut GR8	2
34	99751005	3/4-16 X 2" Hex Bolt Gr8	2	62	99503014	1/2" SAE Flat Washer GR8	2
35	99752001	3/4-16 Nylok Nut Gr8	2				
<b>Lower Control Arm To Car</b>							
36	99501005	1/2-13 X 3 1/2" Bolt GR8	2				
37	99503001	1/2" SAE Flat Washer	4				
38	99502001	1/2-13 Nylok Nut	2				

## Getting Started.....

Congratulations on your purchase of the Ridetech TruTurn System. This System has been designed to give your Mustang excellent handling along with a lifetime of enjoyment. Some of the key features of the TruTurn System: Ball joint angles have been optimized for the lowered ride height, eliminated rubber bushings to get rid of bushing deflection and provide free suspension movement through the entire range of travel. The geometry has been optimized for excellent handling, driveability and minimal bump steer.

**Note:** These control arms are designed for use with the Ridetech CoilOvers and the MuscleBar swaybar. **The factory shocks and springs or the factory sway bar will not fit these arms.**

**Mini-Starter required to clear TruTurn Centerlink Adapter (not Included).**

### Brake Kits

The Mustang TruTurn Suspension package uses a GM Spindle used on 67-69 F body, 64-72 A body, and 68-74 X body. Any brake kit designed for this spindle will work. It just **needs a 4 1/2" on 5 bolt pattern** to keep the same bolt pattern as the rear of the Falcon.

We collaborated with Baer and Wilwood to develop brake kits that work in harmony with our suspension. Depending on wheel size and your braking needs, both Wilwood and Baer have brake kits that will work with your car. Please visit our website to review options for your application.

**1.** Remove the entire front suspension from the car including the centerlink, idler arm, and pitman arm. Refer to a Factory Service Manual for the proper method. The control arms, spindles, and steering linkage will all be replaced with the TruTurn package.



### Installing Strut Rod T-Bushing

2.

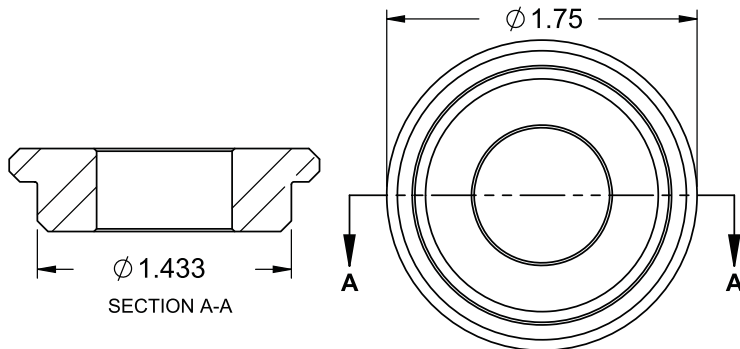

2. This kit includes a t-bushing for the strut rod bushing factory hole.

3.



3. Test fit the t-bushing in your car's strut rod mount to help determine if the strut rod hole needs buffed out. The t-bushing is installed from the front side of the car.

4.



4. Insert 3/4\"-16 x 2\" bolt in the strut rod frame bracket. The head of the bolt needs to be on the side of the bracket with the 2 mounting ears.



### Installing Lower Control Arm



5. With the 3/4"-16 x 2" bolt installed in the bracket, attach the bracket to the front heim of the control arm with the flat side of the bracket on the same side as the ball joint pin. The bracket is installed with a 5/8" ID x .320" spacer on each side of the heim. The spacers need to be installed with the small outside diameter against the heim end. Align the holes of the bracket with the through holes of the spacers and heim. Install a 5/8"-18 x 2 1/4" bolt through the aligned holes. Install a 5/18"-18 thin nylok nut on the threads of the bolt and torque to 45 ftlbs.



6. Insert the 3/4" bolt of the strut rod adapter bracket through the center hole of the t-bushing. The t-bushing and threads of the bolt should be to the front of the car.



7. Install a 3/4"-16 nylok nut on the threads of the bolt sticking through the t-bushing. Torque to 120 ftlbs.



### Installing Lower & Upper Control Arm



8. Install the 2 aluminum spacers into the rod end that goes into the factory control arm pivot. Slip the control arm into the factory frame mount.



9. Align the factory holes with the control arm through hole. Install a 1/2" flat washer on a 1/2"-13 x 3 1/2" hex bolt. Insert the bolt/washer through the aligned holes. Install a 1/2" flat washer and 1/2"-13 nylok nut on the threads of the bolt. Torque to 75 ftlbs.



10. Bolt the upper StrongArm to the body using 1/2"-13 x 2 1/2" bolts, flat washers and lock washers. The ARROW points to the front of the vehicle. A shim is supplied and may need to be installed between the body and the arms to achieve proper alignment. The arms are preset at the factory so the alignment should be close, but the vehicle must be aligned before driving.

**Note:** The upper arm mounting holes on many cars have been redrilled 1" lower. This is done to improve the handling. Our cross shaft has the drop built into it; **make sure to use the factory mounting holes.**



### Upper Control Arm & Spindle Installation



**11.** Install a 1/2" flat washer, 1/2" split lock washer, and 1/2"-13 nut on the threads of the 2 bolts sticking through into the engine compartment. Torque to 75 ftlbs.



**12.** Install the spindle on the lower ball joint pin. Torque the ball joint castle nut to 65 ftlbs and tighten to align the cotter pin holes. Install the cotter pin in the ball joint pin hole and bend the ends of the cotter pin to hold it in place. Install the grease zerk supplied with the ball joint.



**13.** Install the spindle on the upper ball joint pin. Torque the ball joint castle nut to 50 ftlbs and tighten to align the cotter pin holes. Install the cotter pin in the ball joint pin hole and bend the ends of the cotter pin to hold it in place. Install the grease zerk supplied with the ball joint.



### Centerlink Adapter Installation



**14.** The studs with the long hex on them will get installed into the factory centerlink with the taper going into the centerlink, a 7/16" castle nut is used to attach it to the centerlink. The straight shank will point to the front of the car.

**Note:** It may be necessary to install 7/16" washers under the castle nut to get the cotter pin engaged properly.



**15.** Torque the nuts to 35 ftlbs and tighten as needed to align cotter pin. Install cotter pin and bend the ends.

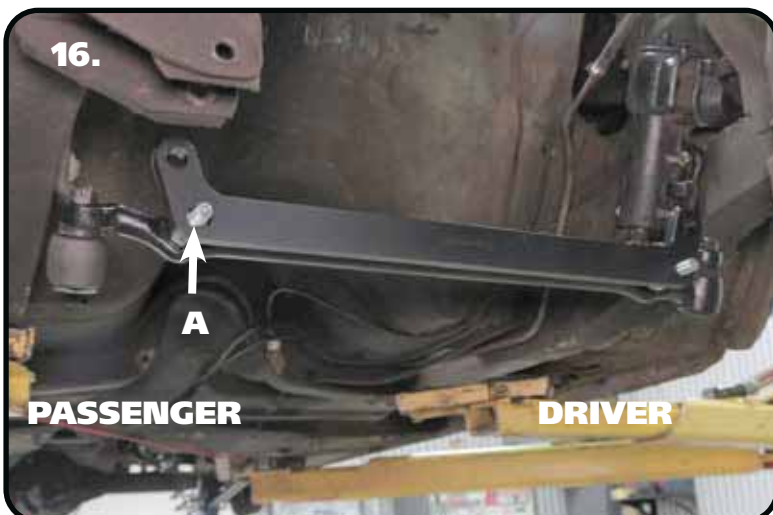

**16.** The centerlink bracket has one attachment hole [A] that is slotted. This is to accommodate the variations in manufacturing and machining processes, as well as any wear that may have occurred to the original centerlink over time. The slot goes on the passenger side centerlink adapter stud.



### Centerlink Adapter Installation



17. Install the 1/2"-20 mechanical locking nuts and torque to 50 ftlbs.



18. The studs with the short hex get installed into the centerlink adapter. The short side goes into the adapter attached with the 5/8"-18 thin top lock nut, with the long side of the stud pointing forward.



19. Install the 5/8"-18 **THIN** mechanical locking nut on the threads of the stud sticking through the centerlink adapter and torque to 45 ftlbs.



### Steering Arm & Stop Installation

20a.

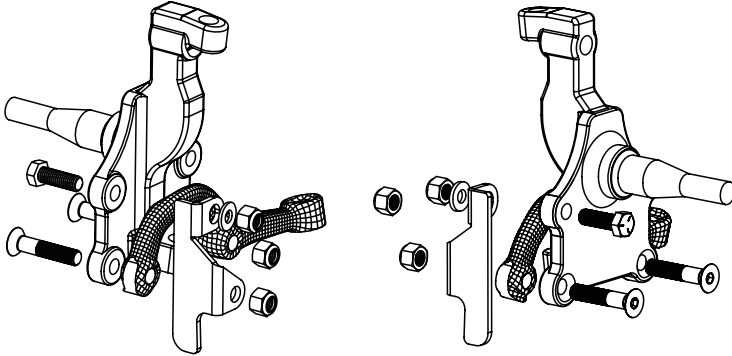

**PASSENGER**

**DRIVER**

**20a.** Install the steering arms and steering stops onto the spindle using **Images 20a & 20b** as a reference. The steering arms angle toward the centerlink, and the tie rod mounting holes are to the rear of the car. The steering stops are marked D and P.

The steering arm is attached to the spindle using 1/2"-20 x 2 1/2" flat socket cap bolts and nylok nuts. Torque to 100 ftlbs.

The upper tab of the steering stop is attached to the spindle using 1/2"-13 x 1 1/2" hex head bolt, 1/2" SAE flat washer, and Nylok. Torque to 75 ftlbs.

20b.

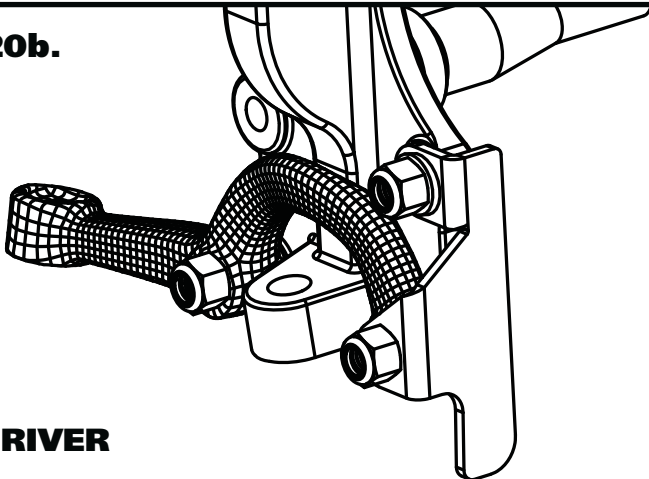

**DRIVER**

**29b.** You will notice in **Image 29b**, the bottom hole of the steering stop is mounted on top of the front steering arm mounting hole. The top mounting tab of the steering stop is on the engine side of the spindle.

21.



**21.** Install the stud with the round flange into the steering arm with the taper going into the steering arm. Torque the nuts to 35 ftlbs and tighten as needed to align cotter pin hole and install cotter pin.



### Tie Rod Assembly & Installation

22.

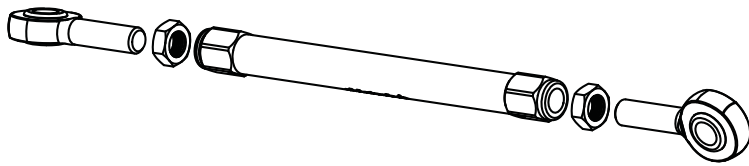

22. The tie rod adjuster has 2 threads in it; 5/8"-18 RH & 5/8"-18 LH. The 5/8"-18 LH thread is marked with a groove on the outside of the adjuster. The tie rod can now be assembled to a center to center length of 14 1/4" to start with, having equal amount of threads on both ends. These aluminum adjusters have a left hand thread on one end and a right hand thread on the other. You should use anti seize when threading the heim ends into the adjuster. **FOR YOUR SAFETY, THE TIE ROD & HEIM NEED A MINIMUM OF 15/16" OF THREAD ENGAGEMENT INTO THE TIE ROD ADJUSTER.**

23.



23. Install one end of the tie rod onto the stud of the centerlink adapter. Install a 5/8"-18 mechanical locking nut on the threads of the stud and torque to 45 ftlbs.

24.



24. Install the outer end of the tie rod on the steering arm stud.



### Tie Rod Installation



25. Install a 5/8"-18 mechanical locking nut. Torque to 45 ftlbs.

26. Double check that you have tightened all hardware to the proper torque. If you are going to install the Ridetech MuscleBar, now is a good time to do it.

#### Suggested Alignment Specs:

Camber: Street: -.5 degrees  
Caster: Street: +3.0 to + 5.0 degrees  
Toe: Street: 1/16" to 1/8" toe in



**Part # 12099551 - 1964-1965 Mustang Crossmember Brace**

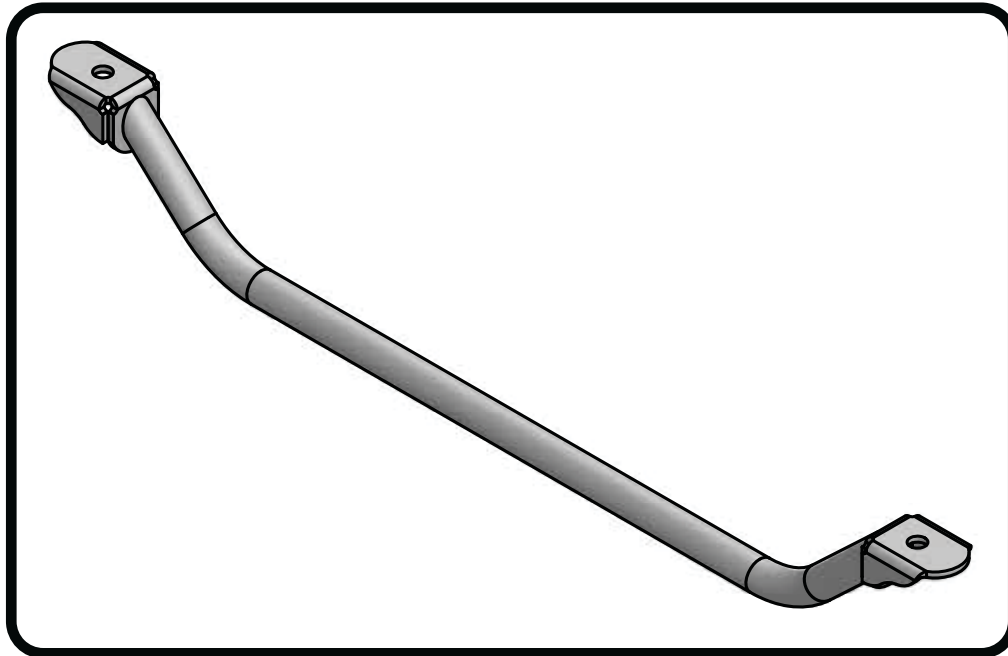

**Recommended Tools**

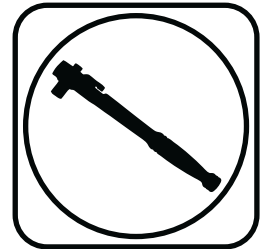

# 64-66 Mustang Crossmember Brace Installation Instructions

Table of contents
Page 17..... Included Components and Installation



### Major Components .....In the box

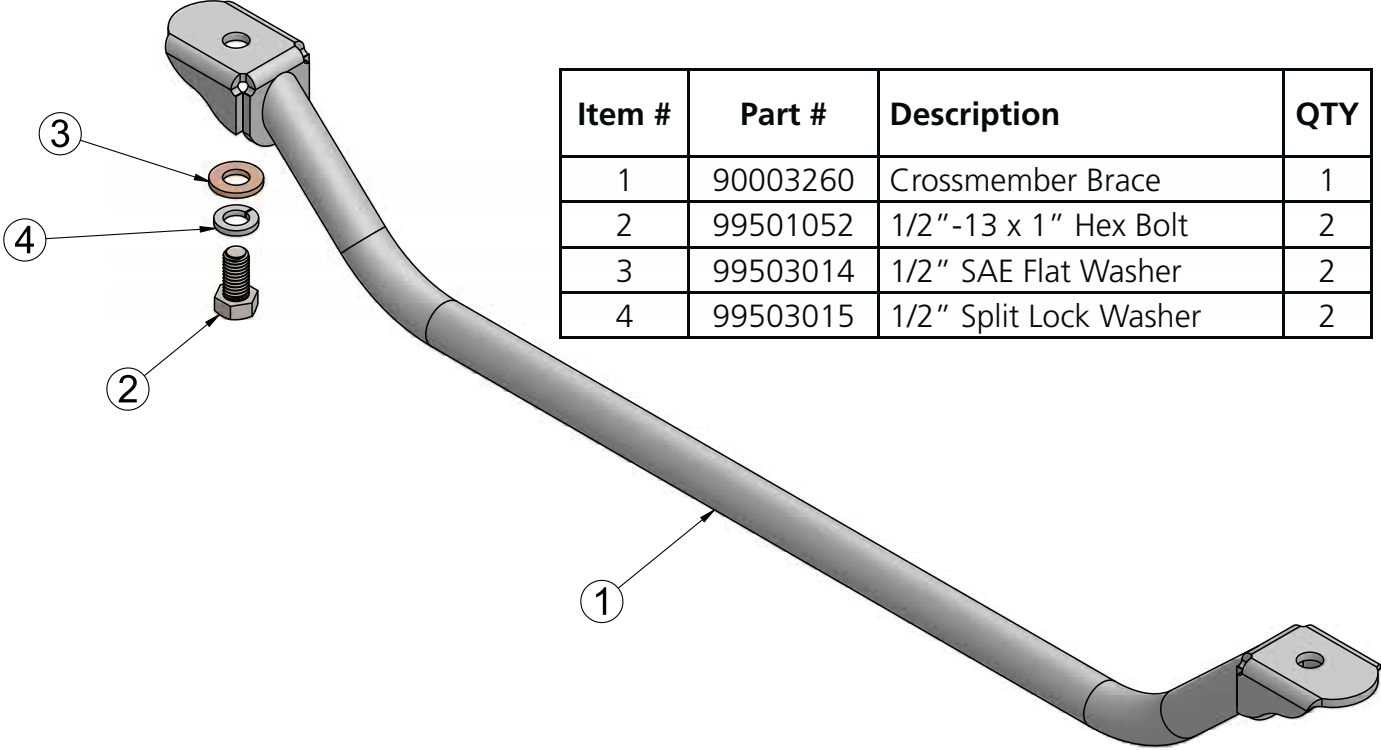

Item #	Part #	Description	QTY
1	90003260	Crossmember Brace	1
2	99501052	1/2"-13 x 1" Hex Bolt	2
3	99503014	1/2" SAE Flat Washer	2
4	99503015	1/2" Split Lock Washer	2



### Brace Installation

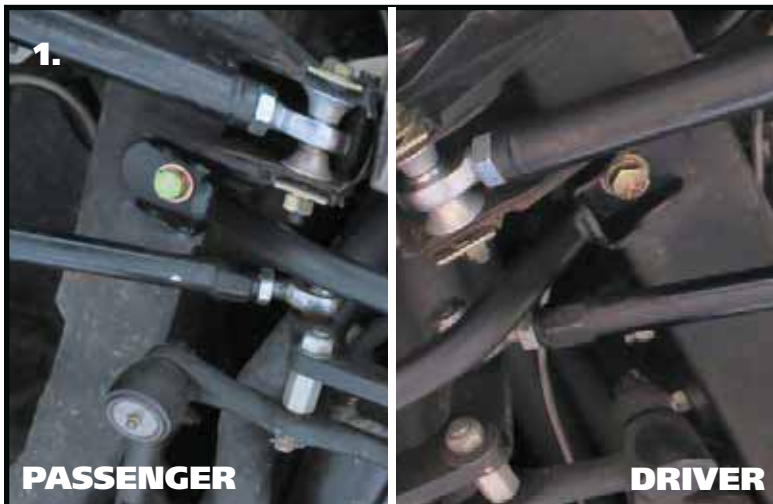

**5.** The new suspension brace bolts in place of the original brace. Install a 1/2" split lock washer & 1/2" flat washer on each of (2) 1/2"-13 x 1" bolt. Position the crossmember brace at the factory location, behind the lower control arm mount. Align the mounting holes of the crossmember with the mounting holes in the frame rails. Install a bolt/washer in each of the mounting holes. Torque the crossmember hardware to 50 ftlbs.