



Part # 12100297 - 1967-1970 Ford Mustang HQ Series ShockWave System

Recommended Tools

Front Components:

12103001	Front ShockWaves
12103699	Upper StrongArms
12102899	Lower StrongArms
12109120	Front SwayBar

Rear Components:

12087197	Rear 4Link System
21150701	Rear ShockWaves

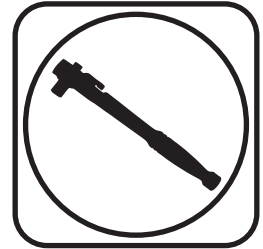

1967-1970 Ford Mustang ShockWaves Installation Instructions

Table of contents

Pages	2-7.....	Front ShockWaves
Pages	8-10.....	Upper StrongArms
Pages	11-15.....	Lower StrongArms
Pages	16-18.....	Front Sway Bar
Pages	19-28.....	Rear 4-Link
Pages	29-30.....	Rear ShockWaves
Pages	31-32.....	Notes & Care of ShockWaves & Shock Adjustment





Part # 12103001 - 67-70 Mustang/Cougar Front HQ Shockwave - StrongArms

Recommended Tools

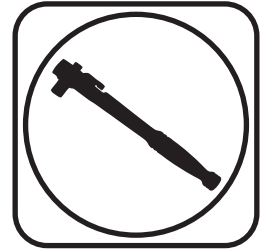
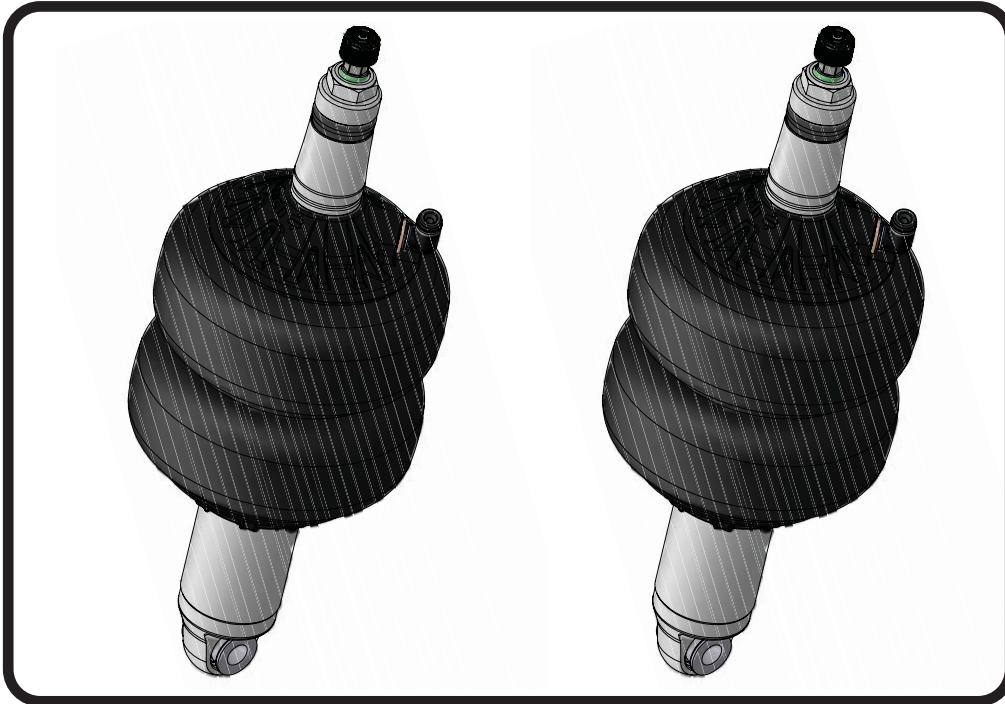

1000 Series Bellow, 2.0" Stud/Eye 2.9" Shock Installation Instructions

THESE SHOCKWAVES ARE DESIGNED TO BE USED WITH RIDETECH STRONGARMS

Table of contents

Page 3..... Included Components

Page 4-6..... Shockwave Installation

Page 7..... Notes and Care of Your Shockwave

ShockWave Dimensions:

Mount to Mount:

Compressed: 9.60"

Ride Height: 11.00"

Extended: 11.90"

www.ridetech.com



REV1 6/3/21



Major ComponentsIn the box

Item #	Part #	Description	QTY
1	982-10-802	2.9" Stroke HQ Series Shock	2
2	90009988	2" Stud Top (Installed on Shock) - Includes Adjuster Knob & Screw	2
3	24090199	1000 Series 6.5" Double Convolute AirSpring	2
4	234-00-153	AirSpring Locking Ring (Installed on shock)	2
5	99055000	Locking Ring Set Screw (Installed on shock)	2
6	90002041	1/2" ID Bearing Spacers	4
7	90002312	2" Aluminum Stud Top Base	2
8	90001904	Bottom Delrin Ball	2
9	90001903	Top Delrin Ball	2
10	90001902	Delrin Ball Aluminum Top Cap	2
11	99562003	9/16"-18 Thin Nylok Nut	2
12	210-35-120-0	Adjuster Knob - (90009988 assembly)	2
13	90009969	#4-40 X 1/4" SS, 18-8 Pan Head Torx Cap - (90009988 assembly)	2
14	90002356	Upper ShockWave Mount	2
15	90003357	Top Cover Plate	2
	90001994	5/8" ID Bearing (installed in shock and eyelet)	4
	90001995	Bearing Snap Ring (installed in shock and eyelet)	8

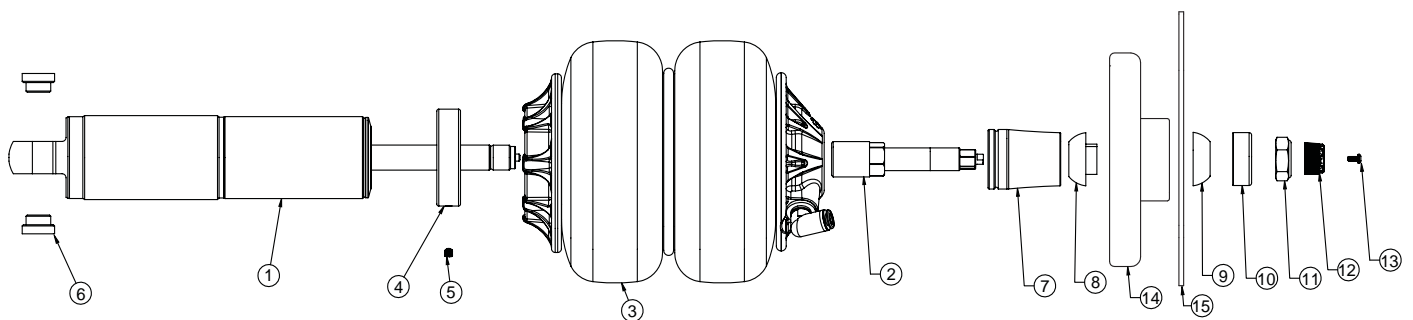

WARNING: ATTEMPTING TO REMOVE THE AIR FITTING WILL DAMAGE IT AND VOID THE WARRANTY.

Hardware Kit..... #99010195

QTY	Part Number	Description
UPPER PLATE MOUNTING		
6	99371027	5/8"-18 Nylok Nut
6	99621010	5/8"-18 x 4" Hex Bolt
6	99623001	5/8" SAE Flat Washer

QTY	Part Number	Description
SHOCK MOUNT TO BODY		
6	99501050	1/2"-13 X 2 1/2" Hex Bolt
6	99623010	1/2"-13 Nylok Nut
6	99561004	1/2" SAE Flat Washer
1	90002263	Red Loctite



ShockWave Installation



1. Install the Ridetech StrongArms. Also, it is easier to install the ShockWave with the coil spring shield removed.

2. We recommend drilling the holes in the large area of the key hole openings to 3/8". Do this for each key hole in the driver and passenger shock towers.



3. Slip the 3/8"-16 x 1" carriage bolts into the slots of the shock tower before bolting in the aluminum mount. **You can NOT slip the carriage bolts in with the upper mount bolted in place.**



4. Hold the aluminum upper mount against the bottom of the shock tower lining up the threaded holes with the holes drilled out in the shock tower.



ShockWave Installation



5. Install a 5/16" split lock washer & 5/16" SAE flat washer on each of (3) 5/16"-18 x 1" button head cap screws. Apply red loctite to the threads of each of the bolts. Hold the lower mount in position and thread the mounting bolts into the (3) mounting holes. Torque the bolts to 13 ft-lbs.



6. Lay the upper plate on top of the shock tower with the ShockWave mount protruding through the large center hole.



7. Install the export brace on the bolts sticking through the top plate. Install a 3/8" SAE flat washer & 3/8"-16 nylok nut on the threads of each of the bolts. Torque the nylok nuts to 15 ft-lbs.



ShockWave Installation

8.

1. Stud top aluminum base
2. Delrin ball lower half
3. Delrin ball upper half
4. Aluminum cap
5. 9/16" SAE Nylok jam nut
6. Threaded stud (screwed onto shock shaft)
7. Rebound adjusting knob
8. Screw

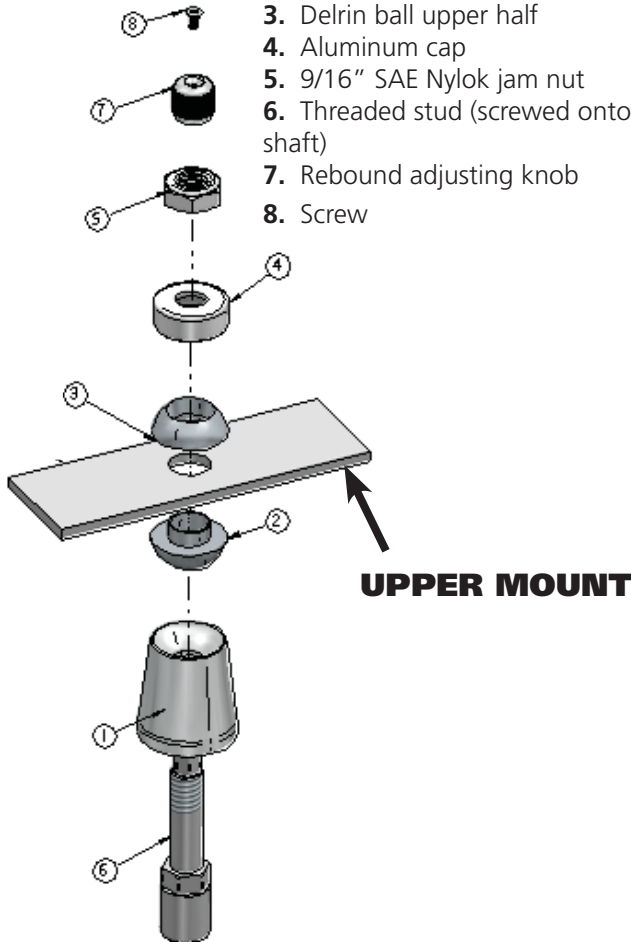

Note: The airline must also be routed at this time.

8. The air fitting location can be rotated by twisting the bellow assembly separate of the shock. Place the Shockwave into the coil spring pocket with the stud sticking through the OEM shock hole. See assembly **Diagram 8**.

1. Stud top aluminum base

2. Delrin ball lower half

UPPER MOUNT

3. Delrin ball upper half

4. Aluminum cap

5. 9/16" SAE Nylok jam nut

6. Threaded stud (screwed onto shock shaft)

7. Rebound adjusting knob

8. Screw

TIGHTENING THE TOP 9/16"-18 NUT: SNUG THE NUT DOWN AGAINST THE TOP CAP. YOU NEED TO BE ABLE TO ARTICULATE THE SHOCK BY HAND. WE TORQUE THE NUT TO 80 INLBS USING A 7/8" CROWS FOOT WRENCH ON A TORQUE WRENCH.

9. Install the a Bearing Spacer in each side of the Bearing. The SMALL part of the spacer inserts into the Inside Diameter of the shock bearing. Raise the lower arm up to the Shockwave and bolt them together using the 1/2" x 2 1/4", & Nylok Nuts supplied with the StrongArms. Torque to 50 ftlbs.

10. Reattach the outer coil spring shield. A hole can be drilled into it to allow airline access to the Shockwave. Use a rubber grommet to prevent airline damage.

Check air spring clearance through full suspension travel. Allowing the air spring to rub will cause failure and is not a warrantable situation.

11. Ride height should be around 90 psi but will vary to vehicle weight and driver preference.

9.





Notes and Care of your Shockwaves

NOTES:

WARNING: ATTEMPTING TO REMOVE THE AIR FITTING WILL DAMAGE IT AND VOID THE WARRANTY.

TIGHTENING THE TOP 9/16"-18 NUT: SNUG THE NUT DOWN AGAINST THE TOP CAP. YOU NEED TO BE ABLE TO ARTICULATE THE SHOCK BY HAND.

You can clock the airfitting location on the ShockWave by turning the AirSpring assembly of the shock. Make sure the fitting doesn't contact the frame.

When cutting the airline, use a razor blade. The cut needs to be a clean cut and square for the airline to seal properly.

The Locking ring on the shock is NOT adjustable. These rings are set at the factory to optimize the AirSpring stroke with the shock stroke.

The care and feeding of your new ShockWaves

1. Although the ShockWave has an internal bumpstop, **DO NOT DRIVE THE VEHICLE DEFLATED RESTING ON THIS BUMPSTOP. DAMAGE WILL RESULT.** The internal bumpstop will be damaged, the shock bushings will be damaged, and the vehicle shock mounting points may be damaged to the point of failure. This is a non warrantable situation.
2. Do not drive the vehicle overinflated or "topped out". Over a period of time the shock valving will be damaged, possibly to the point of failure. This is a non warrantable situation! If you need to raise your vehicle higher than the ShockWave allows, you will need a longer unit.
3. The ShockWave is designed to give a great ride quality and to raise and lower the vehicle. **IT IS NOT MADE TO HOP OR JUMP!** If you want to hop or jump, hydraulics are a better choice. This abuse will result in bent piston rods, broken shock mounts, and destroyed bushings. This is a non warrantable situation.
4. Do not let the ShockWave bellows rub on anything. Failure will result. This is a non warrantable situation.
5. The ShockWave product has been field tested on numerous vehicles as well as subjected to many different stress tests to ensure that there are no leakage or durability problems. Failures have been nearly nonexistent unless abused as described above. If the Shockwave units are installed properly and are not abused, they will last many, many years. ShockWave units that are returned with broken mounts, bent piston rods, destroyed bumpstops or bushings, or abrasions on the bellows will not be warrantied.



Part # 12103699

1967-1970 Mustang/Cougar Front Upper StrongArms



Recommended Tools

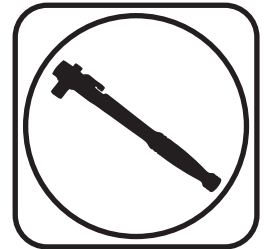

1967-1970 Mustang/Cougar Upper StrongArms Installation Instructions

Table of contents

Page 9..... Upper Control Arm Components
Page 10..... Installations

THESE CONTROL ARMS ARE DESIGNED TO BE USED WITH RIDETECH COILOVERS/SHOCKWAVES AND RIDETECH LOWER STRONGARMS.

THESE CONTROL ARMS HAVE THE "SHELBY MOD" BUILT INTO THE CROSS SHAFT. THIS MOD LOWERS THE CONTROL ARM PIVOT FOR BETTER CAMBER GAIN DURING SUSPENSION TRAVEL.





Upper Control Arm ComponentsIn the box

Item #	Part Number	Description	QTY
1	90000115	Upper Control Arm	2
2	90000930 kit	Upper Ball Joint Kit - Moog # K8036	2
3	90000931	Billet Cross Shaft	2
4	90001589	Heim End - 3/4"-16 thread x 5/8" ID	4
5	90000113	Alignment Shim	2
6	99752004	3/4"-16 Jam Nut	2
7	99621021	5/8"-18 x 2" Gr.8 bolt	4
8	99623002	5/8" Gr. 8 Lock Washer	4
9	99623001	5/8" SAE Gr. 8 Flat Washer	4
10	99501010	1/2"-20 x 2 1/4" Gr.8 Bolt	2
11	99502003	1/2"-20 Thin Nylok Nut	2
12	99501003	1/2"-13 x 2 1/2" Gr.5 Bolt	4
13	99503001	1/2" SAE Flat Washer	8
14	99503002	1/2" Lock Washer	4
15	99502006	1/2"-13 Hex Nut	4

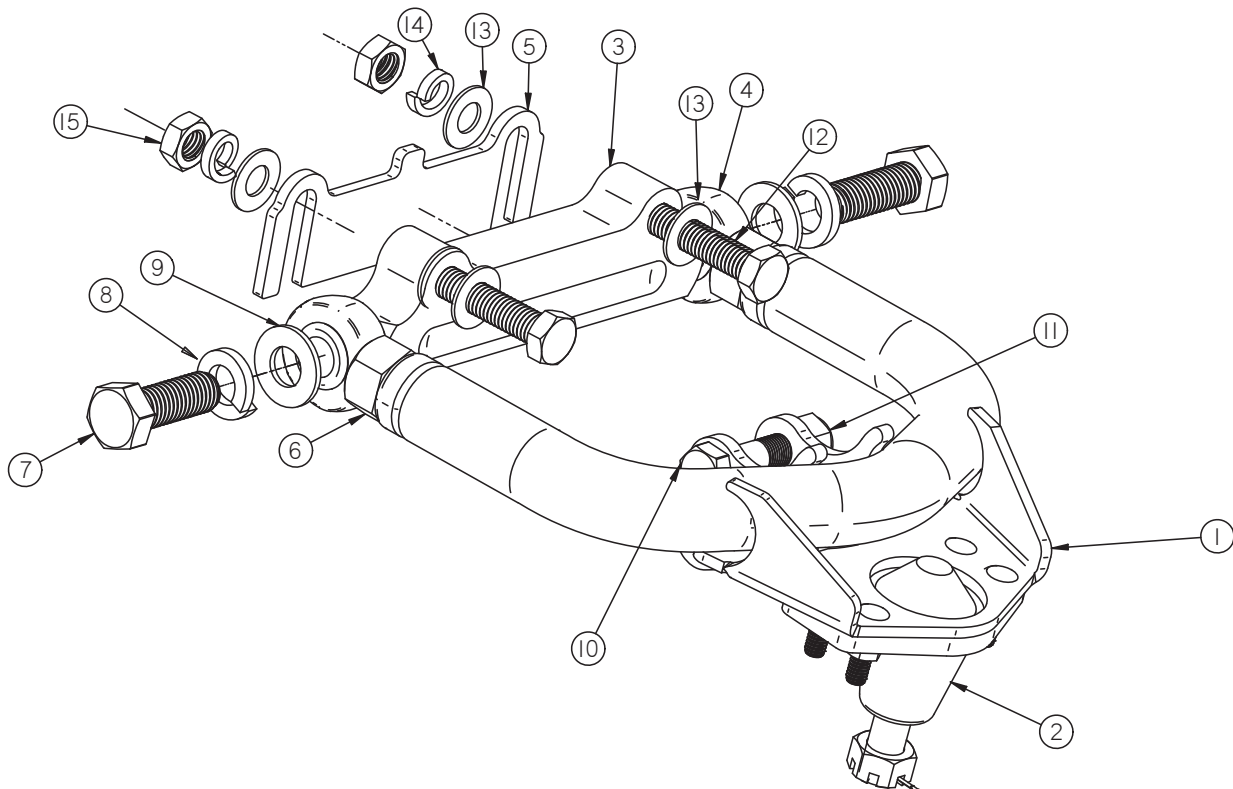



Installation

1. Remove the shocks, coil springs & upper control arms from the car. If you are replacing the lower control arms, remove them too. Refer to a Factory Service Manual for the proper method.



THE UPPER CONTROL ARMS ARE IDENTICAL, SO THEY WILL FIT EITHER SIDE.

2. Bolt the upper StrongArm to the body using $\frac{1}{2}$ " x $2\frac{1}{2}$ " bolts, flat washers and lock washers. A shim is supplied and may need to be installed between the body and the arms to achieve proper alignment. Torque to 75 ft-lbs.

Note: The upper arm mounting holes on many cars have been redrilled 1" lower. This is done to improve the handling. Our cross shaft has the drop built into it, make sure to use the factory mounting holes.



3. Attach the Spindle to the control arms.

Torque Specs:

Upper Ball Joint - 60 ftlbs and tighten to line up cotter pin.

Install the Cotter Pin after tightening the ball joint nut.



4. Attach the Shockwave to the upper StrongArm using a $\frac{1}{2}$ " x $2\frac{1}{4}$ " bolt and Nylok nut. Torque to 75 ft-lbs.

Note: The arms are preset at the factory so the alignment should be close, but the vehicle must be aligned before driving.

Suggested Alignment Specs:

Camber:	Street:	-.5 degrees
Caster:	Street:	+3.0 to + 5.0 degrees
Toe:	Street:	1/16" to 1/8" toe in



Part # 12102899

1967-1970 Mustang/Cougar Front Lower StrongArms

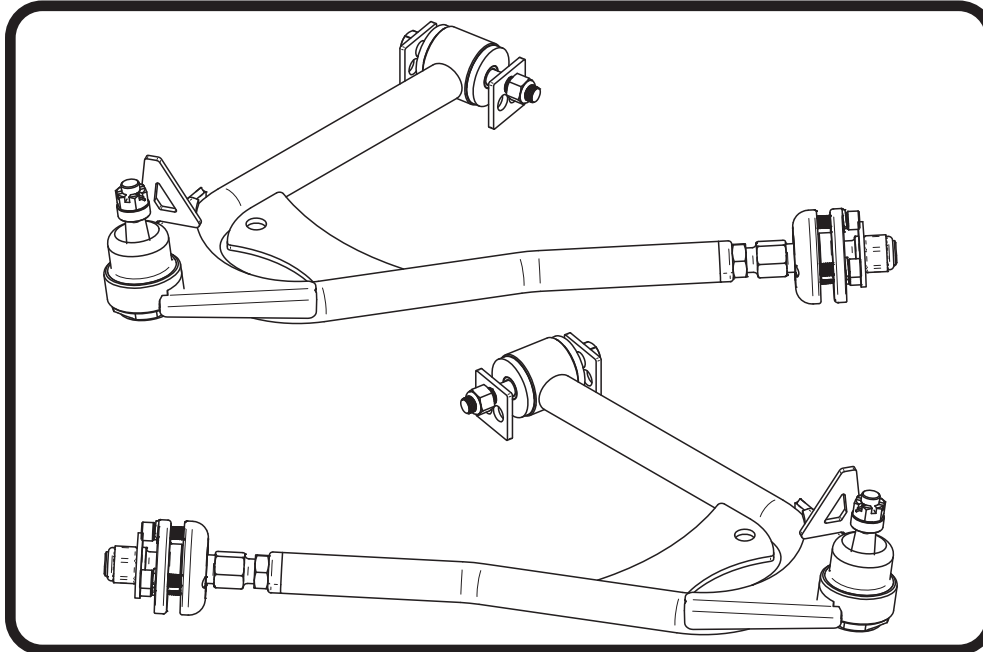

Recommended Tools

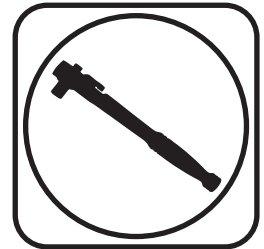

1967-1970 Mustang/Cougar Lower StrongArms

Installation Instructions

Table of contents

- Page 12..... Lower Control Arm Components
- Page 13-15..... Installations

THESE CONTROL ARMS ARE DESIGNED TO BE USED WITH RIDETECH COILOVERS/SHOCKWAVES AND RIDETECH UPPER STRONGARMS.





Upper Control Arm ComponentsIn the box

Item #	Part Number	Description	QTY
1	90000110	Lower Control Arm - Driver - (Shown)	1
1	90000111	Lower Control Arm- Passenger	1
2	90000895 kit	Ball Joint Kit - Moog # K772	2
3	90001086	Bushing Half	4
4	90000108	Inner Bushing Sleeve	2
5	90000732	Bearing Stud - set to 2 15/16"	2
6	99752004	3/4"-16 Jam Nut	2
7	90000734	Pivot Bearing Housing	2
8	90001045	Pivot Bearing	2
9	90000109	Pivot Bearing Retaining Plate	2
10	90000733	Aluminum Pivot Bearing Spacer	2
11	90002283	Ball Joint Castle Nut Spacer	2
12	90000112	Eccentric Eliminator	4
13	99752001	3/4"-16 Lock Nut	2
14	99753002	3/4"x 2" Flat Washer	2
15	99501034	1/2"-13 x 4 1/2" Gr.8 Bolt	2
16	99503014	1/2" SAE Flat Washer	8
17	99502009	1/2"-13 Nylok Nut	2
18	99371019	3/8"-16 x 1 1/2" SHCS	6
19	99373006	3/8" Split Lock Washer	6
	99250001	Grease Zerk	2

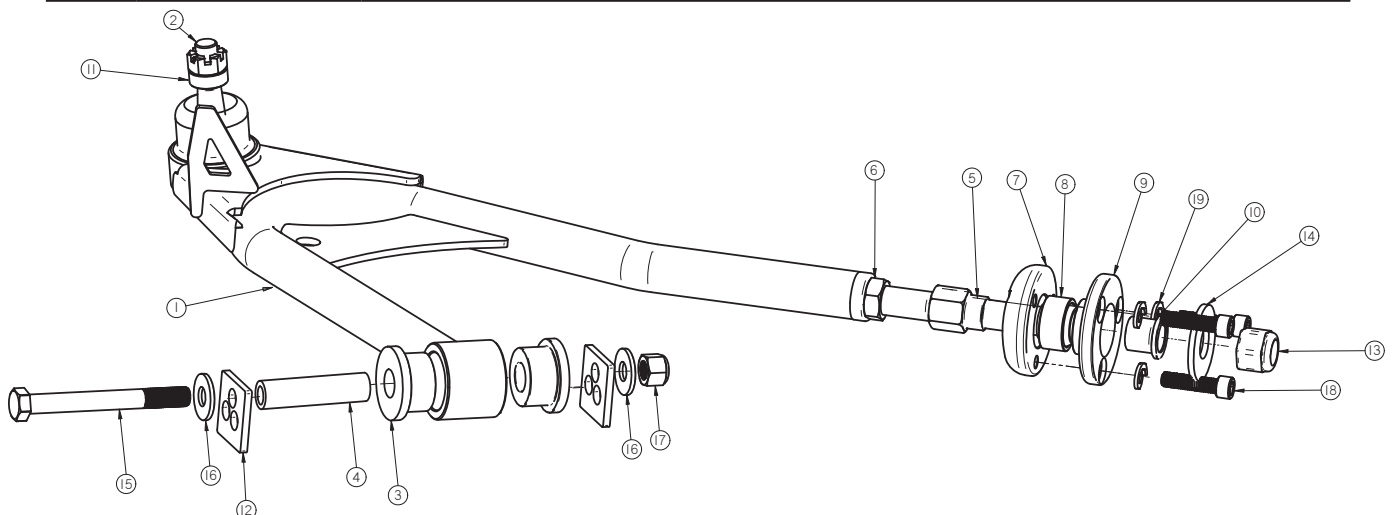



Getting Started.....

Congratulations on your purchase of the Ridetech Mustang StrongArms. These StrongArms have been designed to give your Mustang excellent handling along with a lifetime of enjoyment. Some of the key features of the StrongArms: Ball Joint angles have been optimized for the lowered ride height. The Geometry has been optimized for excellent handling, and drive ability. The control arm is a 1-piece control arm to eliminate the strut rod and bushing.

Note: These control arms are designed for use with the Ridetech ShockWaves or CoilOvers. **The factory shocks and springs will not fit these arms.**

Installation

1. Raise and support vehicle at a safe, comfortable working height. Let the front suspension hang freely.
2. Remove the lower control arms, and the strut rods.

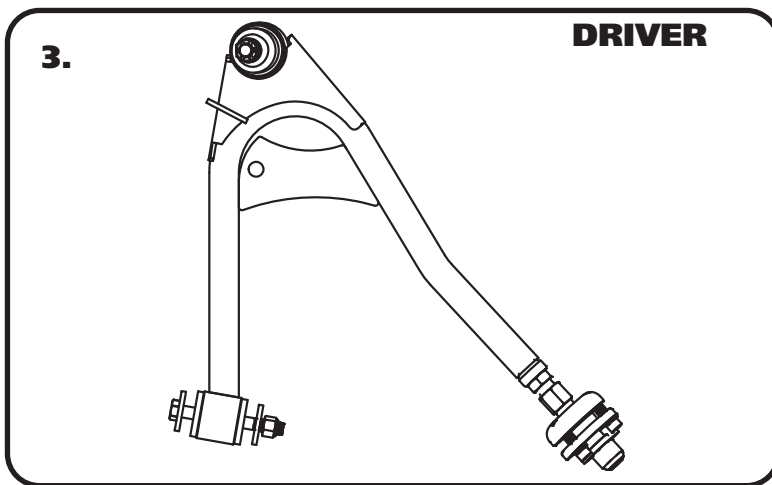

3. The control arms are marked "D" for Driver and "P" for Passenger. The ball joint pin points down and the sway bar mount is on the front side of the arm.



4. Be sure to remove the outer bushing sleeve from the strut rod frame mount.

Note: Remove any excess undercoating or rust.



Control Arm Installation



5. Using the bearing retainer as a template; drill three 3/8" holes in the frame to secure the assembly. Use three 3/8" x 1 1/4" SHCS and lock washers to secure the assembly. Torque to 30 ft-lbs.

Note: The hole in the frame may need to be buffed to allow bearing retainer plate to slide in.



6. Slide the stud through the bearing, then slide the aluminum spacer over the stud with the larger end toward the front of the car. Secure the assembly with a 3/4" Nylok Nut and flat washer. Use **Images 6 & 7** as a guide.

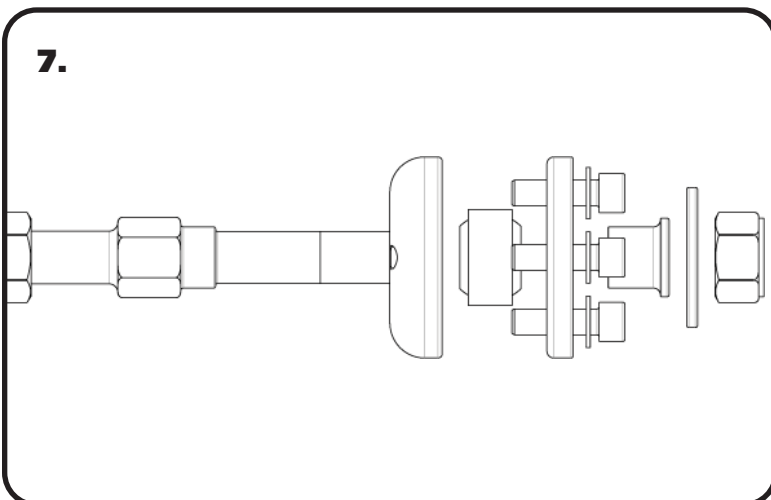

7. The front leg of the lower arm will attach to the frame in place of the strut rod. Refer to **Diagram 7** for assembly order. Torque the 3/4"-16 nut to 75 ft-lbs.



Control Arm Installation



8. Eccentric eliminator plates are included, one must be installed on each side of the frame. Start out with it in the center, make sure both plates are in the same position. Attach the other end of the lower control arm to the factory frame mount using a 1/2" x 4 1/2" bolt and Hex nut. Torque to 50 ft-lbs. Install the grease zerk in the control arm sleeve.



9. Slide the ball joint boot over the ball joint, then place the spindle over the ball joint stud. A ball joint spacer will be necessary to align the castle nut with the cotter pin hole. Grease ball joint. Attach the spindle to the control arms.

Torque Specs:

Lower Ball joint - 70 ft-lbs and tighten to line up cotter pin.

Install the cotter pin after tightening the ball joint nut.

10. Lubricate control arm bushing with Lithium grease.

Suggested Alignment Specs:

Camber:	Street: -.5 degrees
Caster:	Street: +3.0 to + 5.0 degrees
Toe:	Street: 1/16" to 1/8" toe in



Part # 12109120 - 1967-1970 Mustang Front SwayBar



Recommended Tools



1967-1970 Mustang Front SwayBar Installation Instructions

Table of contents
Page 17..... Included Components and Hardware List
Page 17-18.... SwayBar Installation

Hardware Torque Specifications

M10-1.5.....	37 ftlbs
3/8"-16.....	35 ftlbs

Major ComponentsIn the box

Part #	Description	QTY
90002952	SwayBar	1
90002953	Bushing Strap Spacer	2
70015013	Lined SwayBar Bushing	2
90001344	SwayBar Bushing Strap	2
90001258	SwayBar End Link T-Bushing	4
END LINK ASSEMBLY		
90001256	90 Degree End Link Adapter	2
90002571	90 Degree End Link	2
99375008	3/8"-16 x 3" Threaded Stud	2
90002930	End Link Kit	2

HARDWARE KIT 99010213

QTY	Part Number	Description
4	99371019	3/8"-16 x 1 1/2" Socket Head Cap Screw
4	99373002	3/8" SAE Flat Washer
4	99372001	3/8"-16 Nylok Nut
4	99373020	3/8" ID x 5/8" OD Flat Washer

Getting Started.....

Note: This sway bar kit utilizes a anti-friction lining in the sway bar bushing. The lining allows the sway bar to move freely and quietly in the bushing. No lubrication is required.

1. Jack the vehicle up to a safe working height and support with jack stands. Make sure the jack stands are stable before working under the car.
2. Remove the stock sway bar.



3. Open the sway bar bushing at the split and slip it **OVER** the sway bar. Do this for both bushings.

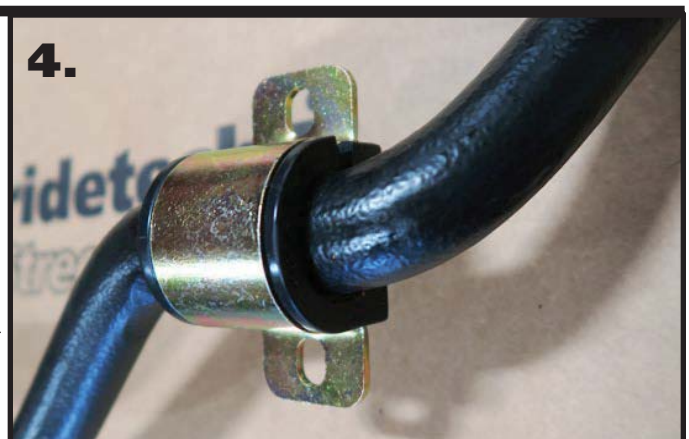

4. Slip the bushing straps over the swaybar bushings.

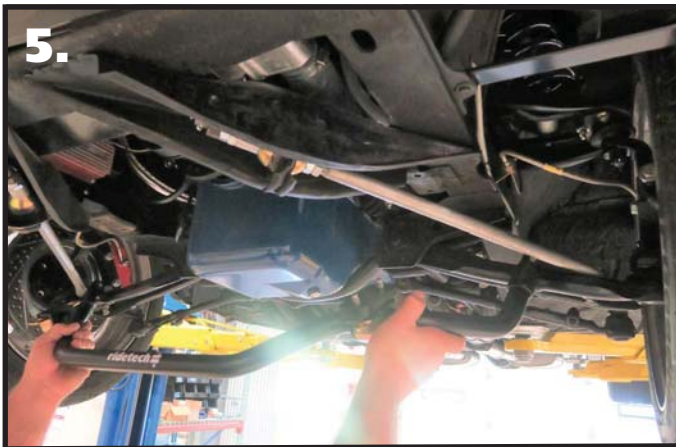

5.

5. Install the sway bar in position in the car. The center of the bar should be to the front of the car. The outer arms of the sway bar will bend upward. Use **Picture 6** as a reference.

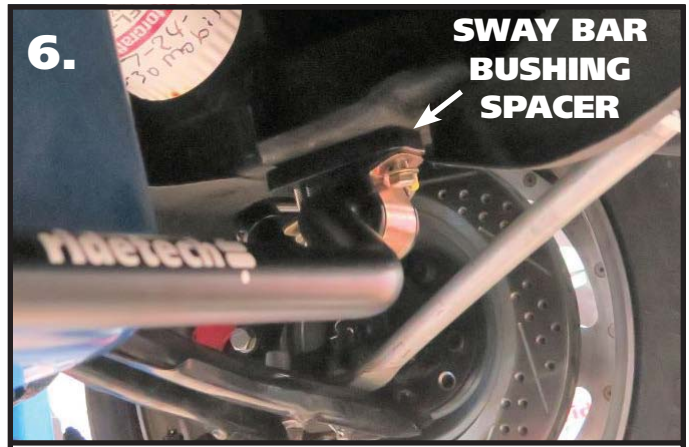

6.

SWAY BAR BUSHING SPACER

6. Install a 3/8" flat washer on each of the (4) 3/8" x 1 1/2" bolts. The sway bar bushing spacer will be installed between the sway bar bushing and frame. Push the bar up to the frame, installing the spacer in place. Hold it in position and install (2) bolt/washers in each side. Install a 3/8" flat washer & 3/8" nylok nut on the bolts and snug the hardware.

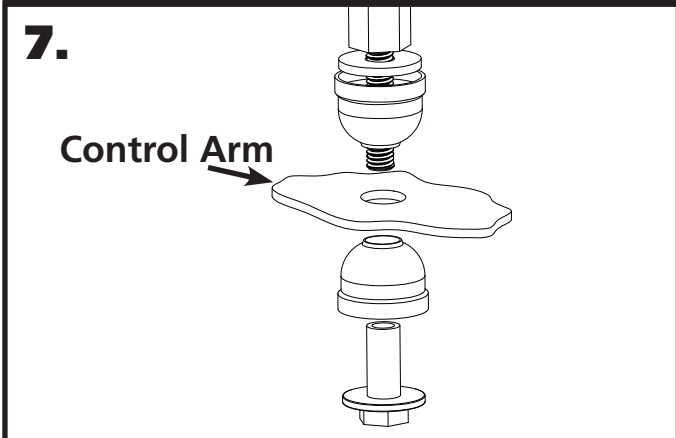

7.

Control Arm

7. Install the End Links using **Diagram 7** as a reference. Tighten the end link barrel nut until it is flush with the end of the bolt, and then tighten it 2 more complete rounds.



8.

8. Install a T-Bushing on each of the 90 degree end links. The t-bushings are installed with the large diameter against the shoulder of the end link.



9. Insert the 90 degree end link/t-bushing into the swaybar end with the threads pointing toward the engine. Install a 2nd t-bushing with the small diameter into the swaybar. Install the nut and torque. Do this for both sides.

10. Torque the swaybar mounting hardware.



Part # 12087197 -1965-1970 Mustang Rear Bolt-in 4 Link

Recommended Tools

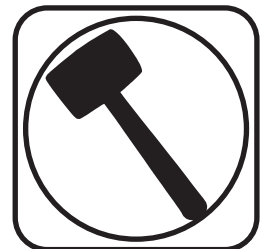
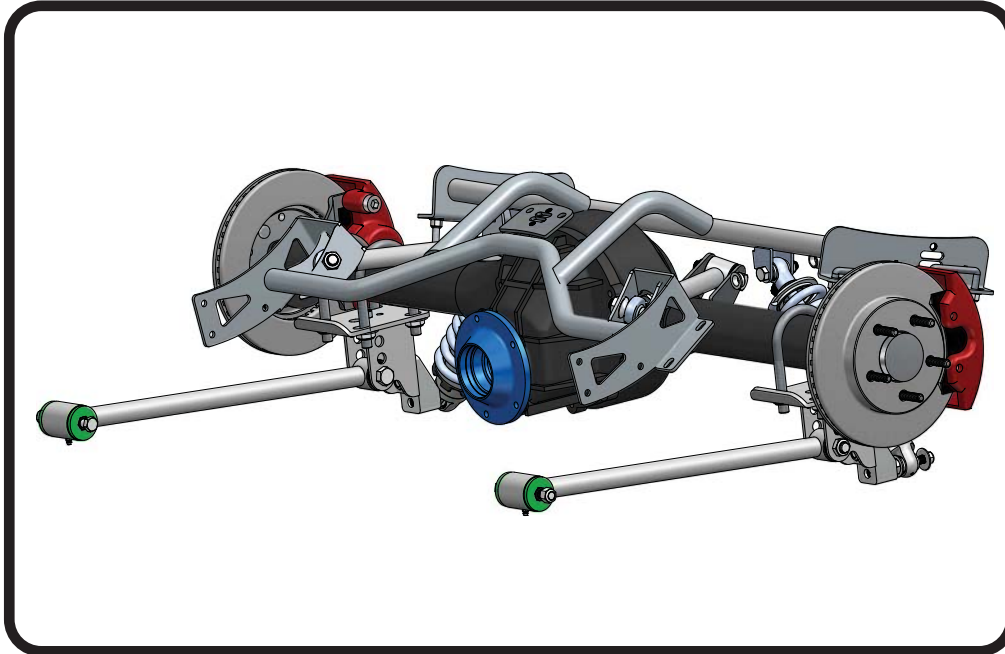

1965-1970 Mustang Rear Bolt-in 4 Link Installation Instructions

Table of contents

Page 20.....	Included Components
Page 21.....	Hardware List
Page 22.....	Getting Started & Cradle Installation
Page 23.....	Lower Axle Mount Installation
Page 24.....	R-Joint Bar Assembly
Page 25.....	Setting Pinion Angle
Page 26.....	Upper Bar Axle Tab Installation
Page 27.....	Installing Lower Bars & Axle Tabs
Page 28.....	Installing Axle Tabs & ShockWaves/CoilOvers

NOTE: If your car is equipped with a differential that has the axle tubes swedged to 2 1/4", you will need (4) 99566009 u-bolts. See page 3.





Major ComponentsIn the box

Item #	Part #	Description	QTY
1	90002198	Upper Cradle	1
2	90001444	Lower Axle Mount	2
3	90003094	Lower Bar Assembly - 21 3/4" center to center	2
4	70013539	Front Lower Outer R-Joint Spacer	2
5	90003091	Upper Bar - 11 3/4" center to center	2
6	70013364	RH R-Joint Threaded Housing End (installed in bars)	4
	70013564	LH R-Joint Threaded Housing End (installed in bars)	4
7	70011897	Upper Bar Tab - Tall	4
8	70012018	Upper Bar Tab - Short	2
9	90001624	Aluminum Lower Shock Mount	2
10	70002825	Lower Shock Stud	2
11	70013334	R-Joint Spacers	14
12	90002285	Square U-Bolts	7
13	99566001	Axle U-Bolts	4
14	99752004	3/4" -16 RH Jam Nut (installed on R-Joint Ends)	4
	99752006	3/4" -16 LH Jam Nut (installed on R-Joint Ends)	
	90002067	Lower Shock Spacers	4
	70010694	Bar Tab Setting Jig	2
R-Joint Components - (Installed in bar ends)			
	70013279	Retaining Ring	8
	70013280	Wavo Wave Spring	8
	70013275	R-Joint Center Ball	8
	70013276	R-Joint Composite Center Ball Cage	8

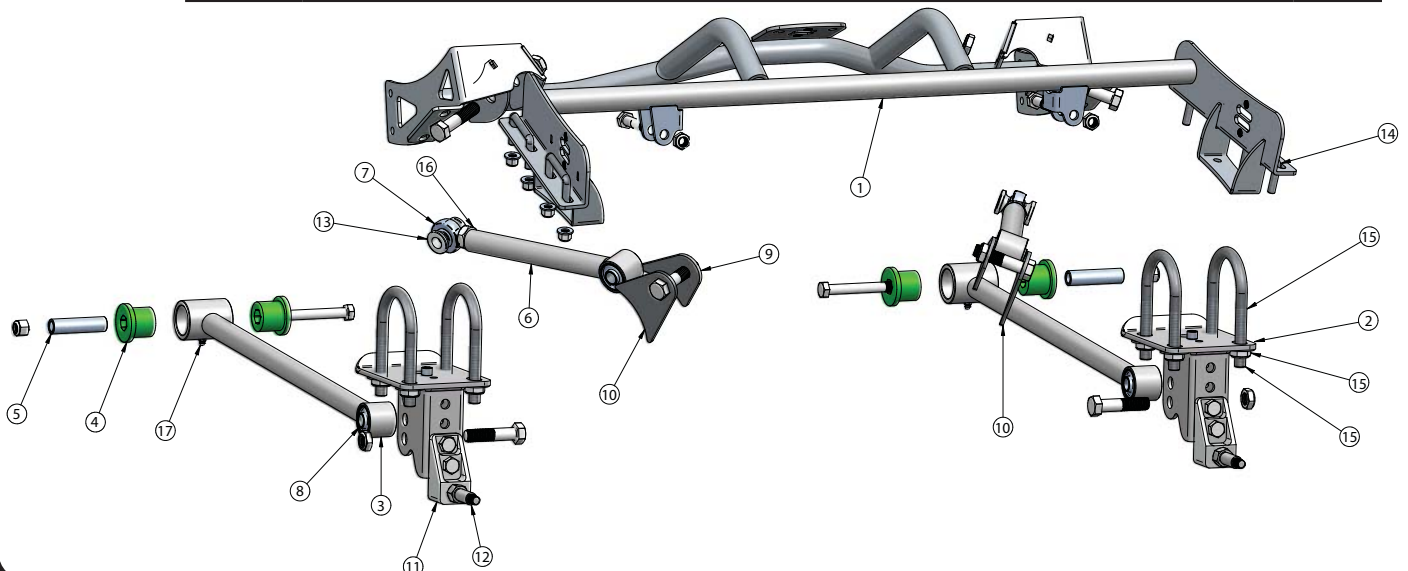



Hardware ListIn the box (Kit# 99010054)

QTY	Part Number	Description	QTY	Part Number	Description
4-Link Bars to Mounts			U-bolts		
6	99621003	5/8" x 2 3/4" Gr. 8 Bolt	8	99566003	9/16" SAE Flat Washer
6	99622006	5/8" SAE Nylok Jam Nut	8	99566002	9/16"-18 Hex Nut
Cradle to Car			Front Lower bar to Chassis		
14	99372002	3/8-16" Nylok Nut	2	99501029	1/2"-20 x 6 1/2" Hex Bolt
14	99373003	3/8" SAE Flat washer	2	99501017	1/2"-20 x 4 1/2" Hex Bolt
6	99373007	3/8"-16 Thread Forming Bolts	2	99502002	1/2"-20 Nylok Nut
Shock Mount to Axle Mount			Bar Setting Jig		
2	99501007	1/2"-20 x 1 1/4" Hex Bolt	2	99371001	3/8"-16 x 3/4" Hex Bolt
2	99501009	1/2"-20 x 1 3/4" Hex Bolt	2	99372004	3/8"-16 Hex Nut
4	99502002	1/2"-20 Nylok Nut	Shock Stud		
Shock to Cradle			2	99432002	7/16"-20 Nylok Nut
2	99501010	1/2"-20 x 2 1/4" Hex Bolt	2	99433002	7/16" SAE flat Washer
2	99502003	1/2"-20 Thin Nylok Jam Nut	2	99623004	5/8" SAE Flat Washer
4 Link Bar Assembly					
4	99752004	3/4"-16 RH Jam Nuts			
4	99752006	3/4"-16 LH Jam Nuts			
2	90002276	Anit-Sieze			

R-JOINT SPACER INSTALLATION

Install the Spacers by inserting the SMALL side of the SPACER into the Center Pivot Ball. Push them in until they bottom out and stop.

LOWER FRONT R-JOINT

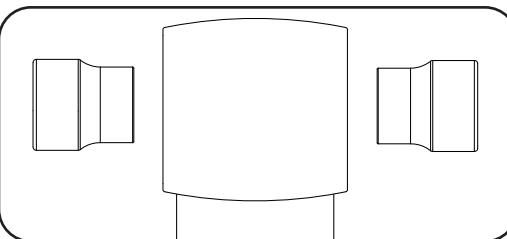

ALL OTHER R-JOINTS

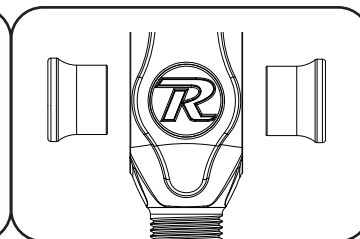

New R-Joints will be quite stiff (75-90 in/lbs breakaway torque) until they "break in" after a few miles of use. After the break in period they will move much more freely. Because the composite bearing race contains self lubricating ingredients, no additional lubrication is needed or desired. Any additional lubrication will only serve to attract more dirt and debris to the R-Joint and actually shorten its life.



SWEDGED AXLE TUBES! - IF YOUR CAR EQUIPPED WITH A DIFFERENTIAL THAT HAS THE ENDS OF THE AXLE TUBES SWEDGED TO 2 1/4", YOU WILL NEED DIFFERENT U-BOLTS. YOU WILL NEED (4) OF RIDETECH PART # 99566009.



Getting Started.....

Congratulations on your purchase of the Ridetech Rear 4-link System. This system has been designed to give your Mustang excellent handling along with a lifetime of enjoyment. Some of the key features of this system: Tune ability, Replaces the Leaf Springs, this allows the 4-Link to locate the rearend and the CoilOvers/ShockWaves to support the car.

Note: These system is designed for use with the Ridetech Shockwaves or CoilOvers. **The factory shocks and springs will not fit this setup.**

1. Raise the vehicle to a safe and comfortable working height. Use jack stands to support the vehicle with the suspension hanging freely.
2. Support the axle and remove the leaf springs, shocks and tail pipes. Refer to the factory service manual for proper disassemble procedures. You might have to detach the fuel line from the frame rails.

Cradle Installation

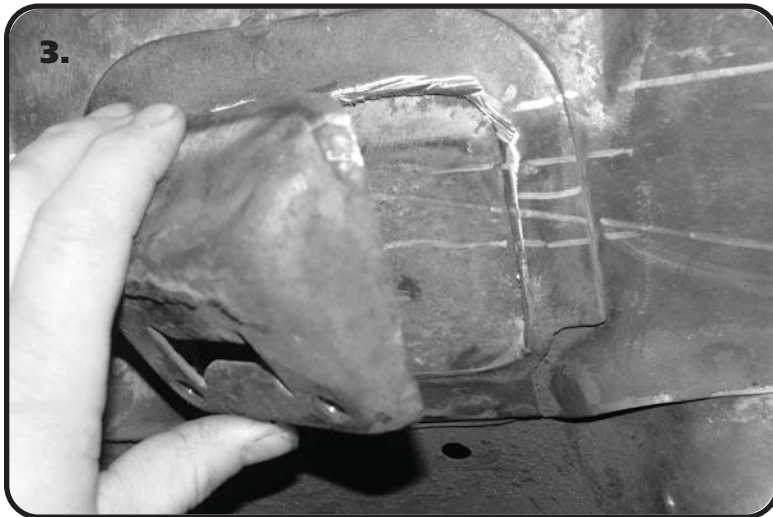

3. Remove the Factory Pinion Snubber and Mount from the car. We use a cut off wheel to remove the mount. Notice that we left the mounting lip of the mount attached to the car. This provides another layer of metal for the Front Tab of the Upper Cradle to attach too.

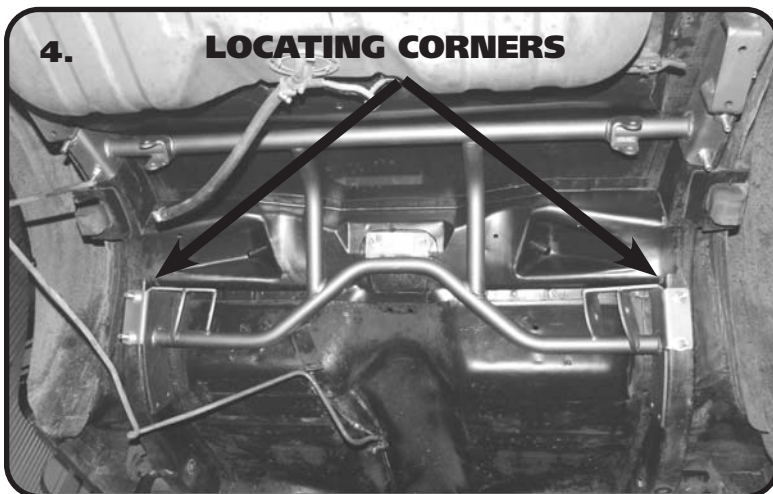

4. Install the cradle into the car. The rear corners of the Upper Bar Mounts locate into the front corner of the factory shock sheet metal mount. The Cradle is held in by (7) 3/8" Square U-bolts. Use the Cradle as a locator for drilling the holes. Drill the holes using a 7/16" drill bit. Drill The front 3 holes on each side with a 5/16" drill bit.

Note: The OEM fuel line will need to be detached from the frame rails until the Cradle is installed.



Lower Axle Mount Installation



5. You will notice that the holes are drilled in pairs. Each pair will receive a Square U-bolt. To insert the Square U-bolts into the holes it may be necessary to lower the Cradle to install them. The U-bolts are installed by inserting one end into one of the drilled holes, using the other end as a handle, feed it through the frame until the inserted end will drop down through the remaining hole. Do this for all (7) U-bolts. Install the Cradle into position. Install (1) 3/8" Flat washer and (1) 3/8" Nylok nut onto each stud sticking through the cradle. Do not tighten them until all Washers and Nuts are installed. Install the 3/8" Thread Forming bolts into the 5/16" holes.

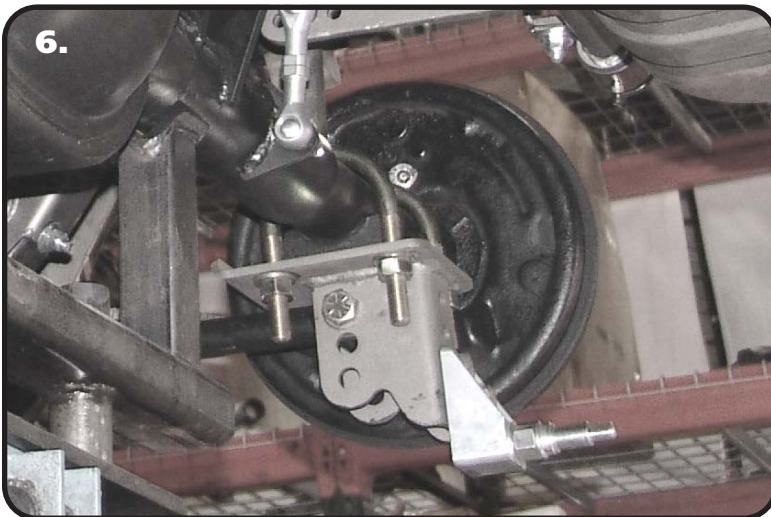

6. Install the Lower Axle Mount onto the Axle using the supplied U-Bolts. Run the nuts down to hold the mount in place, but DO NOT tighten yet.

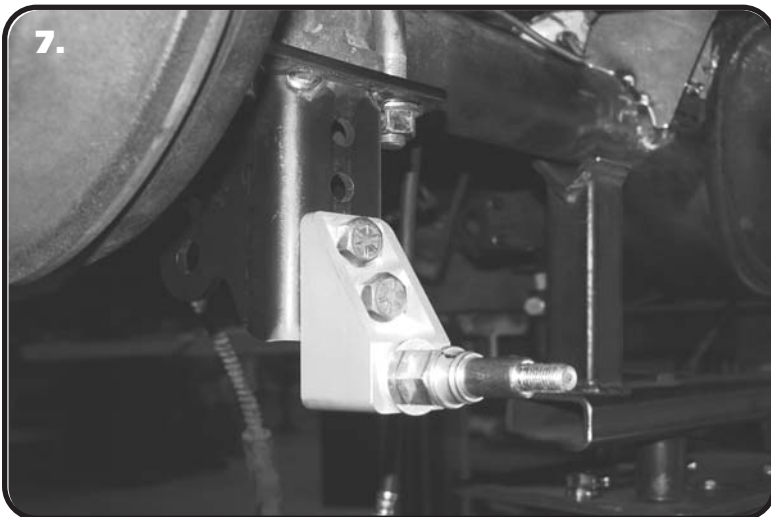

7. Attach the Lower Shock Mount to the Axle Mount using (1) 1/2"-20 x 1 1/4", (1) 1/2"-20 x 1 3/4" Hex Bolts, and (2) 1/2"-20 Nylok Nuts on each mount. The Shock Mount is installed in the BOTTOM 2 holes of the Axle Mount. Install a Shock Stud and 5/8" washer in each Shock Mount. Tighten the mounting hardware and the Shock Stud.



R-Joint Bar Assembly

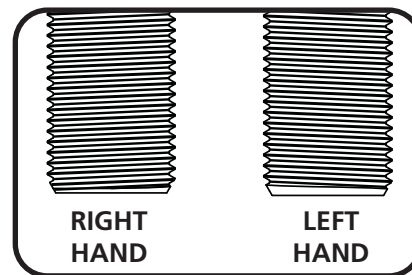
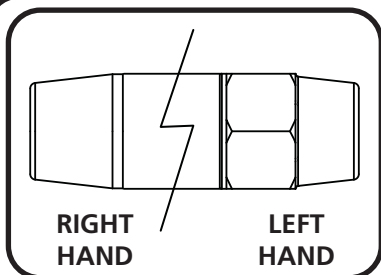

THE 4-LINK BARS, R-JOINTS, AND JAM NUTS HAVE RIGHT HAND AND LEFT HAND THREADS. THIS ALLOWS THE BAR TO BE ADJUSTED WITHOUT REMOVING IT. THE HEX END OF THE BAR IS LEFT HAND THREAD. THE LEFT HAND JAM NUT HAS AN COUNTER-CLOCKWISE ARROW STAMPED INTO IT. IMAGE 3 WILL HELP YOU DETERMINE THE THREADS OF THE R-JOINTS.

14a. Component List:

1. 4-Link Bar
2. Right Hand Thread R-joint
3. Right Hand Thread Jam Nut
4. Left Hand Thread R-Joint
5. Left Hand Thread Jam Nut

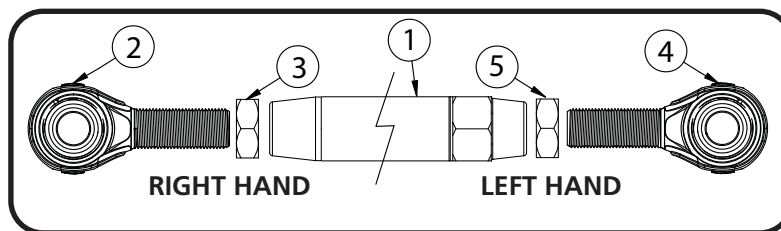

14b. Thread the jam nuts onto the threaded shank of the r-joints. Thread the nuts all the way on to the r-joint.

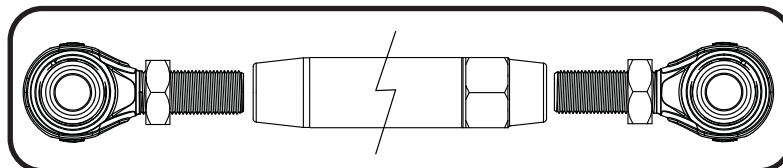

14c. *Apply anti-seize to the threads of the r-joint.* This will prevent the threads from galling.



14d. Thread the r-joints into the 4-link bar. Thread them in evenly until you achieve the correct center to center length.

Upper Bar Length: 11 3/4"

Lower Bar Length: 21 3/4"

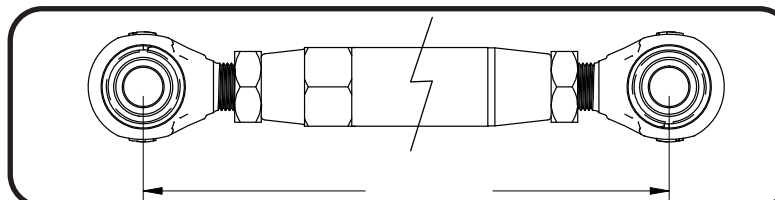

14e. After getting one bar length set, you can put a 5/8" bolt through the r-joints to simplify setting the next bar. Adjust the bar length of the 2nd bar until it will slip on and off the bolts. Torque the jam nuts 65-75 ft-lbs using an 1 1/8" crows foot on a torque wrench.





Setting Pinion Angle

READ PAGES 6-8 ON SETTING PINION ANGLES, UPPER BAR TAB JIG INSTALLATION, & SETTING RIDE HEIGHT.

How do you set the pinion angle? On a single-piece shaft you want to set it up where a line drawn through the center of the engine crankshaft or output shaft of the transmission and a line drawn through the center of the pinion are parallel to each other but not the same line.

Your transmission angle should be around 3 degrees down in the rear. If it is more or less than 3 degrees, you might want to consider changing it. Too little angle on the transmission reduces the amount of oil getting to the rear bushing. Too much transmission angle will increase the working angles of the u-joints which will increase the wear. With the transmission at 3 degrees down in the rear, you will want to set the pinion 3 degrees up in the front.

A simple way to do this is to place a digital angle finder or dial level on the front face of the lower engine pulley or harmonic balancer. This will give you a reading that is 90 degrees to the crank or output shaft unless you have real problems with your balancer. At the other end, you can place the same level or angle finder against the front face of the pinion yoke that is also at 90 degrees to the centerline. If you rotate the yoke up or down so both angles match, you have perfect alignment.

Road testing will tell you if you have it right. If you accelerate and you get or increase a vibration, then the pinion yoke is too HIGH. Rotate it downward in small increments of a degree or two until the problem goes away. If you get or increase a vibration when decelerating, then the pinion yoke is too LOW. Rotate it upward to correct it.

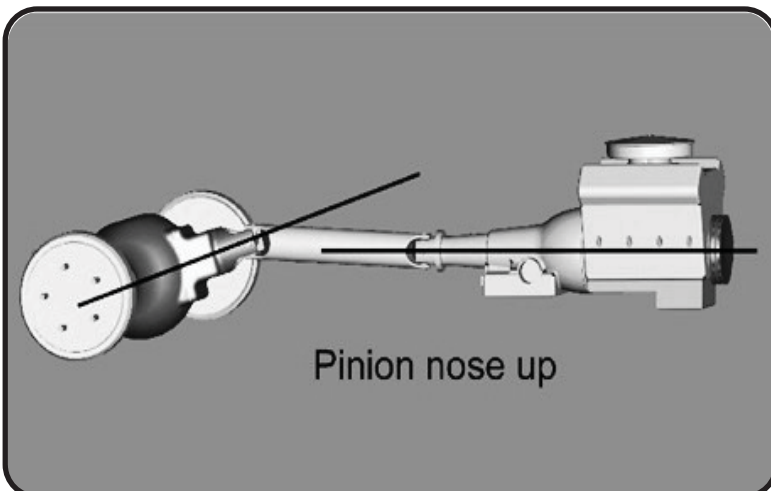
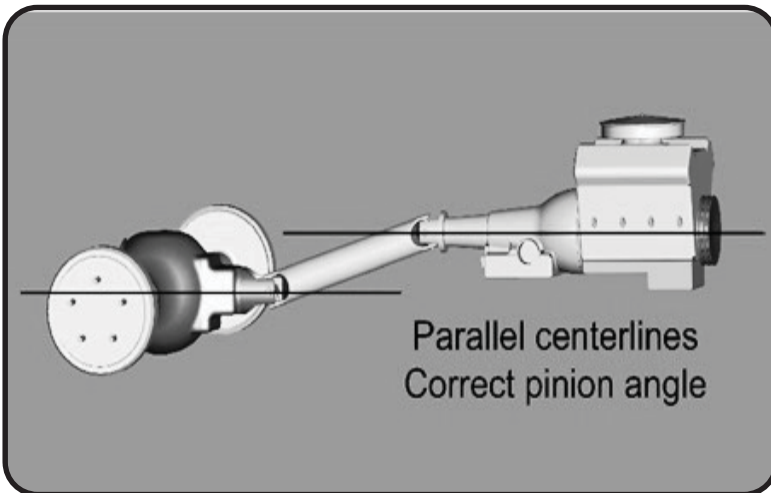
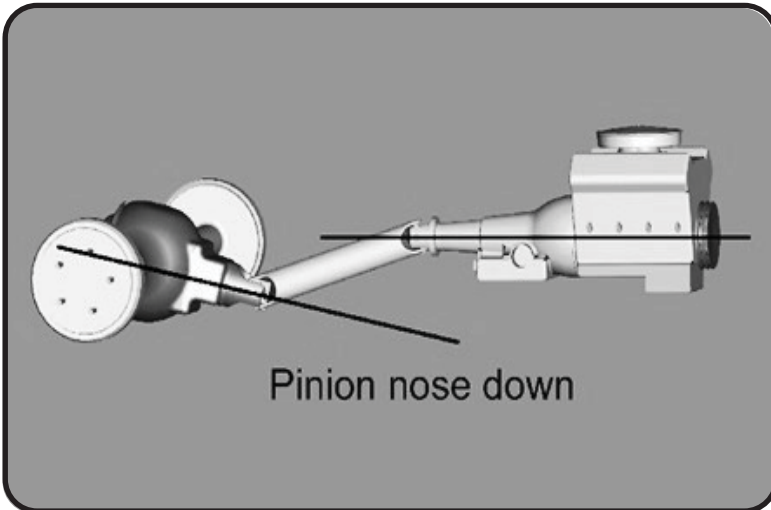



Upper Bar Tab Installation Jig

Upper Bar Installation Jig

- This jig has been supplied to aid in the installation of the upper 4 link bar. It can be temporarily used to properly align, locate and weld the tabs onto the axle. It will also ensure that the mounting bolts are parallel to the ground.
- Follow the diagram below to set the jig to the same length as the upper bar, use the 3/8" x 3/4" bolt and nuts to set the length.
- Position the axle at ride height. Center the axle left to right between the quarter panels. Set pinion angle.
- Bolt one end of the jig to the cradle using a 5/8" x 2 3/4" bolt.
- Using another 5/8" x 2 3/4" bolt, fasten the axle tabs to the other end. The tall tab goes to the outside of the car. The short tab goes to the inside of the car (some cars may need a tall tab on the inside). The tabs must be bolted to the outside of the jig.
- Swing the bar down letting the tabs rest onto the axle. Trim the brackets as necessary to minimize the gap to be welded.
- Check pinion angle, ride height and axle center. Tack-weld the tabs in place.
- Remove jig and install upper bar.
- Repeat this process for the other side.
- Recheck pinion angle, ride height and axle center. (Sound familiar?)
- After the tabs have been tack welded on both sides, remove the upper bars to avoid melting the rubber bushings. Let the axle drop down for better access to the tabs. Lay 1" welds on the inside and outside of the tabs. Skip around from one side to the other to avoid overheating the tube.

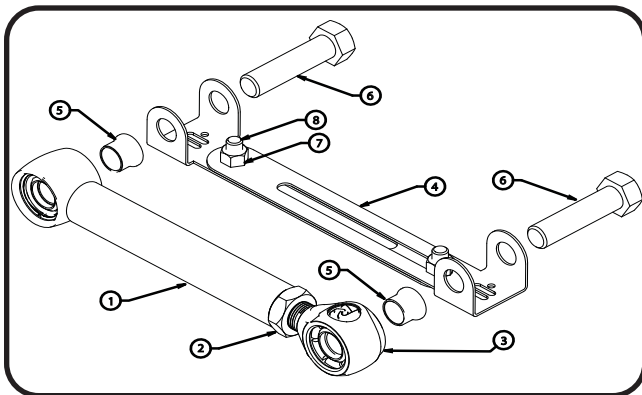

Item#	Description
1	Upper Bar
2	3/4"-16 Jam Nut
3	R-Joint End
4	Alignment Jig
5	Aluminum Spacer
6	5/8" x 2 3/4" Bolt
7	3/8"-16 Nut
8	3/8"-16 x 3/4" Bolt



Installing Lower Bar & Axle Tabs



8. Install the Lower Bars. The Front Lower uses the WIDE(70013539) R-Joint Spacers inserted into the outside of the R-Joint with a NARROW(70013334) inserted on the inside. The Axle end of the bar gets a NARROW(70013334) R-Joint Spacer inserted into each side of the R-Joint. The bar is attached to the Axle Mount in the **TOP HOLE** using (1) 5/8" x 2 3/4" Hex Bolt, and (1) 5/8" Thin Nylok Jam Nut. The front of the Lower Bar is attached with 1/2"x 6" Hex Bolt(64-67) or 1/2"x 4 1/2" Hex Bolt(68-70), and (1) 1/2" Nylok Nut.

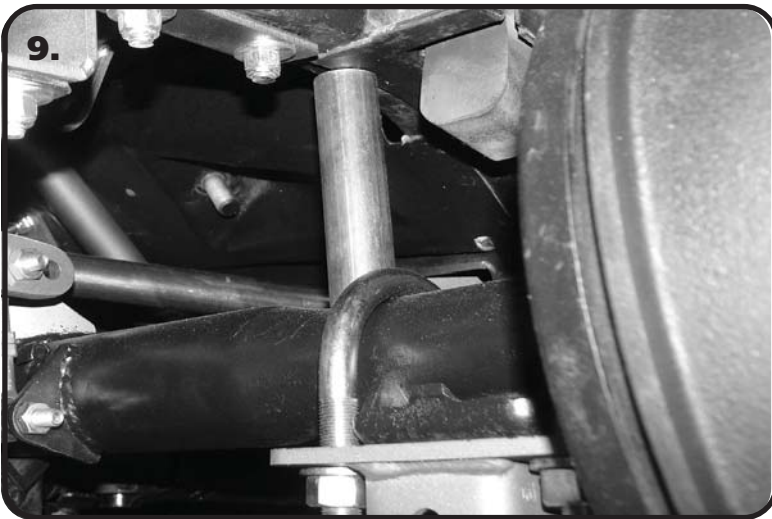

9. One helpful trick to maintain ride height when setting the pinion angle is to put a spacer between the axle and the frame. The spacer should be 4 1/2" tall. Set the pinion Angle and axle center. When measuring the axle center you can measure off of the frame rails. We also use a plum bob off the quarter panels to double check the axle center. Refer to Page 7 on Setting the Pinion Angle.

Note: You can tack weld the spacer in place after you get the Pinion Angle, and Axle Center set. This will ensure that nothing moves through the Upper Tab Installation.

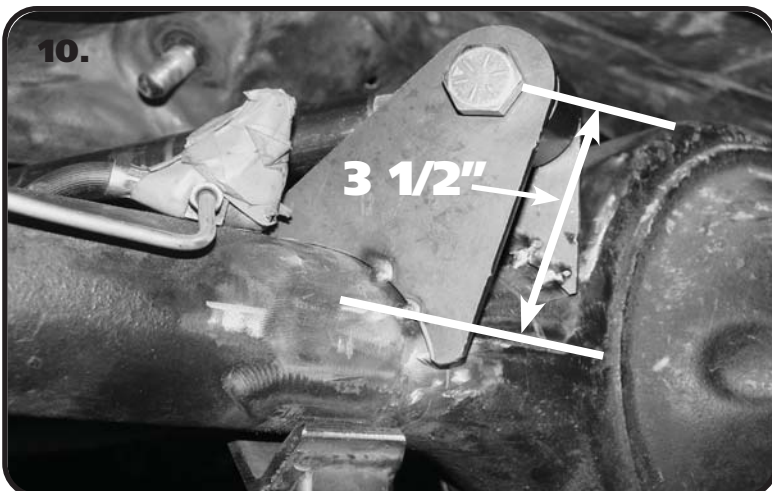

10. Refer to Page 8 and set the length of the Upper Bar Jig and install the Tabs on the Jig. Insert the Jig into the Cradle. Set the Upper Tabs on the Rearend. Due to different variations of the Rearend Housings, it may be necessary to modify the tabs for the best fit. The height you are wanting to achieve with the upper bar end is 3 1/2" from the axle center line. Modify the tabs so that the center of the bar bushing will be 3 1/2" from the center of the axle.



Installing Axle Tabs & Shockwaves/Coilovers

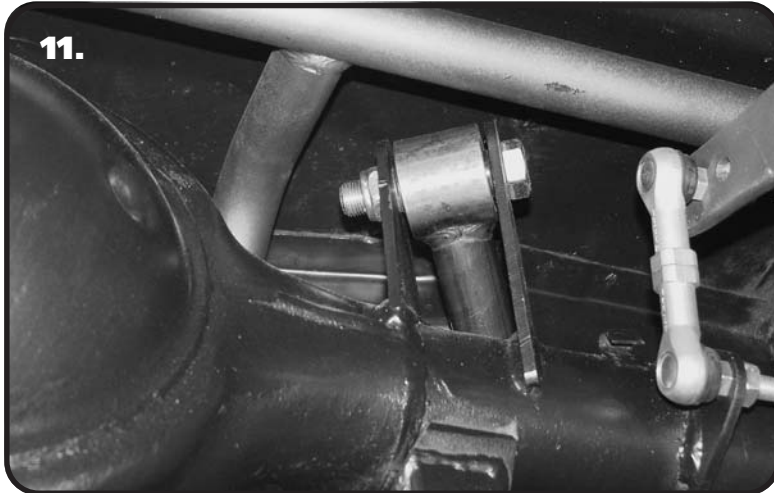

11. Once the bar end height is set, tack weld the tabs to the axle. Do this for the Driver and Passenger side bars. Insert the bars into the Cradle and Tabs to double check fitment. Recheck Axle Center and Pinion Angle. Once satisfied with fitment weld the Upper bar Tabs onto the Axle. Weld 1" at a time, skip around from one side to the other, and one tab to the other to avoid overheating the Axle Tube. When the tabs cool down, insert NARROW(70013334) spacers into each side of the R-Joints of the Upper Bar. Attach the upper bars using (1)5/8" x 2 3/4" Bolt, and (1) 5/8" Thin Nylok Nut.

Remove the Spacer from between the Axle and Frame.

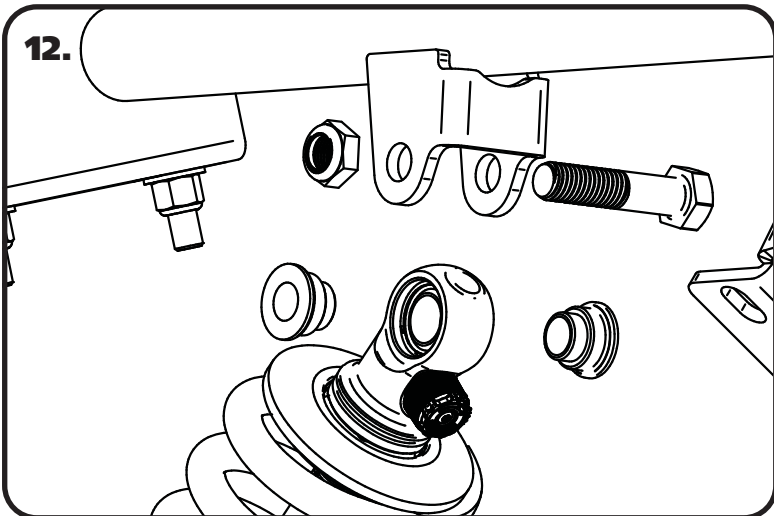

12. Install a 1/2" ID Spacer on each side of the upper Coilover/ShockWave. Slide the assembly into the upper crossmember from the bottom side. If your shock has an adjuster knob position it so that the knob points toward the center of the car. Line up the hole in the spacers with the hole in the upper shock bridge and insert 1/2" x 2 1/2" bolt and install 1/2" Nylok nut.

NOTE: BEFORE INSTALLING SHOCKWAVES
The correct pinion angle must be set first. Failure to do so could result in damage to the ShockWave by the bag rubbing the Lower Axle Mount.

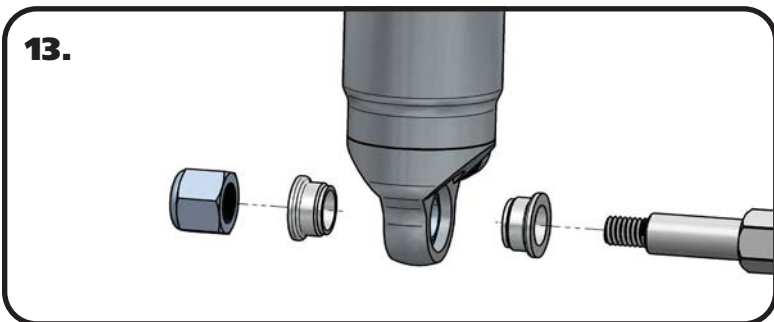

13. Install a 5/8" ID spacer(Small side towards shock body) onto the lower Shock Stud. Slide the bottom of the Shock onto the Stud. Install a second 5/8" ID Spacer onto the Stud(small side towards shock). You may need to jack the rearend up to Slide the Shock onto the Stud. Install the 7/16" Flatwasher and 7/16" Nylok nut. Tighten the upper and lower shock bolts.

Note: If installing Shockwaves and you want to locate the air fitting in a different location, the air spring assembly can be rotated on the shock by grabbing the shock and air spring assembly by hand and spinning the shock in the air spring assembly.

The designed ride height of the CoilOver/Shockwave is 14 1/2" center to center.



Part # 21150701 - 5.2" Stroke HQ Series Shockwave

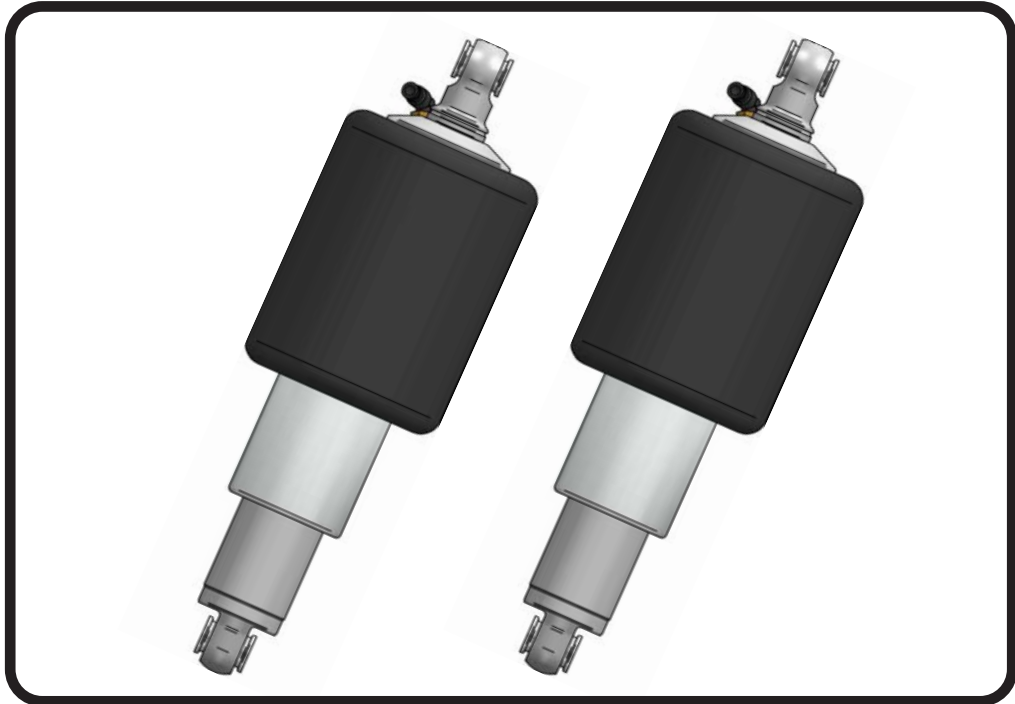

Recommended Tools

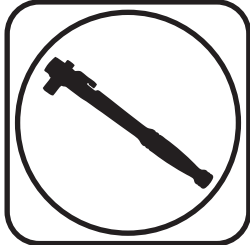

7000 Series Bellow, Eye/Eye 5.2" Shock Installation Instructions

Table of contents

Page 30..... Included Components

Page 31..... Notes and Care of Your Shockwave

Page 32..... Shock Adjustment

ShockWave Dimensions:

Center of bearing to Center of bearing:	
Compressed:	11.85"
Ride Height:	14.60"
Extended:	16.42"



Major ComponentsIn the box

Item #	Part #	Description	QTY
1	982-10-805	5.2" Stroke HQ Series Shock	2
2	815-05-022	Shock Eyelet	2
3	24090799	7000 Series, 4" Diameter AirSpring	2
4	234-00-153	AirSpring Locking Ring (Installed on Shock)	2
5	90002044	Spacer kit - 1/2" ID and 5/8" ID	4
	90001994	5/8" ID Bearing (installed in shock and eyelet)	4
	90001995	Bearing Snap Ring (installed in shock and eyelet)	8

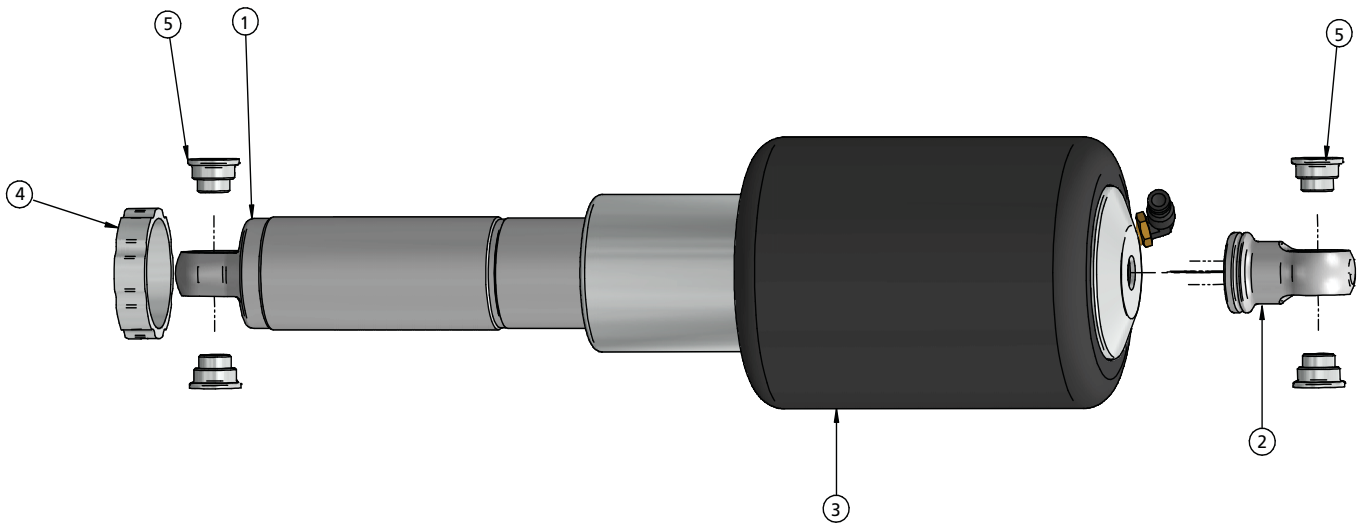

WARNING: ATTEMPTING TO REMOVE THE AIR FITTING WILL DAMAGE IT AND VOID THE WARRANTY.



Notes and Care of your Shockwaves

NOTES:

WARNING: ATTEMPTING TO REMOVE THE AIR FITTING WILL DAMAGE IT AND VOID THE WARRANTY.

You can clock the airfitting location on the ShockWave by turning the AirSpring assembly of the shock. Make sure the fitting doesn't contact the frame.

When cutting the airline, use a razor blade. The cut needs to be a clean cut and square for the airline to seal properly.

The Locking ring on the shock is NOT adjustable. These rings are set at the factory to optimize the AirSpring stroke with the shock stroke.

The care and feeding of your new ShockWaves

1. Although the ShockWave has an internal bumpstop, **DO NOT DRIVE THE VEHICLE DEFLATED RESTING ON THIS BUMPSTOP. DAMAGE WILL RESULT.** The internal bumpstop will be damaged, the shock bushings will be damaged, and the vehicle shock mounting points may be damaged to the point of failure. This is a non warrantable situation.
2. Do not drive the vehicle overinflated or "topped out". Over a period of time the shock valving will be damaged, possibly to the point of failure. This is a non warrantable situation! If you need to raise your vehicle higher than the ShockWave allows, you will need a longer unit.
3. The ShockWave is designed to give a great ride quality and to raise and lower the vehicle. **IT IS NOT MADE TO HOP OR JUMP!** If you want to hop or jump, hydraulics are a better choice. This abuse will result in bent piston rods, broken shock mounts, and destroyed bushings. This is a non warrantable situation.
4. Do not let the ShockWave bellows rub on anything. Failure will result. This is a non warrantable situation.
5. The ShockWave product has been field tested on numerous vehicles as well as subjected to many different stress tests to ensure that there are no leakage or durability problems. Failures have been nearly nonexistent unless abused as described above. If the Shockwave units are installed properly and are not abused, they will last many, many years. ShockWave units that are returned with broken mounts, bent piston rods, destroyed bumpstops or bushings, or abrasions on the bellows will not be warrantied.



Shock Adjustment

Shock Adjustment 101- Single Adjustable

Rebound Adjustment:

How to adjust your new shocks.

The rebound adjustment knob is located on the top of the shock absorber protruding from the eyelet.

You must first begin at the ZERO setting, then set the shock to a medium setting of 12.



-Begin with the shocks adjusted to the ZERO rebound position (full stiff). Do this by rotating the rebound adjuster knob clockwise until it stops.



-Now turn the rebound adjuster knob counter clock wise 12 clicks. This sets the shock at 12. (settings 21-24 are typically too soft for street use).

Take the vehicle for a test drive.



-if you are satisfied with the ride quality, do not do anything, you are set!



-if the ride quality is too soft increase the damping effect by rotating the rebound knob clock wise 3 clicks.

Take the vehicle for another test drive.



-if the vehicle is too soft increase the damping effect by rotating the rebound knob clock wise 3 additional clicks.



-If the vehicle is too stiff rotate the rebound adjustment knob counter clock wise 2 clicks and you are set!

Take the vehicle for another test drive and repeat the above steps until the ride quality is satisfactory.

Note:

One end of the vehicle will likely reach the desired setting before the other end. If this happens stop adjusting the satisfied end and keep adjusting the unsatisfied end until the overall ride quality is satisfactory.