

Exhaust System Installation for Ford Focus RS PN's-60647, 60647CFBA, 140702, 140730, 140730CFBA



******* Please compare the parts in the box with the bill of materials provided *****
to assure that you have all the parts necessary for this installation.**

These instructions have been written to help you with the installation of your Borla Performance Exhaust System. Please read this document completely before beginning the installation of your system.

To ensure this part number fits your specific model year, please visit our website for the latest model year listings at www.BORLA.com

Thank you for purchasing a Borla Performance Cat-Back™ Exhaust System.

Borla Performance Cat-Back™ Exhaust System (PN's-60647, 60647CFBA, 140702, 140730, 140730CFBA) are designed for the Ford Focus RS equipped with a 2.3L EcoBoost Turbo engine and a manual transmission.

Borla Performance Industries recommends that an exhaust shop or professional after market parts installer, who has all the necessary equipment, tools and experienced personnel needed for proper installation, should perform the installation of this system. However, if you decide to perform the installation, we recommend someone should help you. Ensure the installer uses all under car safety precautions including eye protection.

Please take time to read and understand the following...

By installing your Borla Performance Exhaust System, you indicate that you have read this document and you agree with the terms stated below.

It is the responsibility of the purchaser to follow all installation instruction guidelines and safety procedures supplied with your Borla Performance Exhaust System

Borla Performance Industries assumes no responsibility for damages occurring from misuse, abuse, improper installation, improper operation, lack of responsible care, or all previously stated reasons resulting from incompatibility with other manufacturer's products and/or systems.

Included with your Borla Performance Exhaust System is a warranty card. Please read it carefully before you begin any work on your vehicle. If you should have any questions regarding our warranty policy, installation, or any other matter pertaining to your new Borla Performance Exhaust System, please give us a call at the number provided on the warranty card.

Minimum Required Tool List:

TOOLS:

1. 3/8" Drive Ratchet
2. 3/8" Drive Extension 3" & 6"
3. 15mm Deep Well Socket
4. 16mm Deep Well Socket
5. 8mm Socket
6. Pry Bar

SHOP SUPPLIES:

- 1 Spray Lubricant

Borla Performance - Bill of Materials

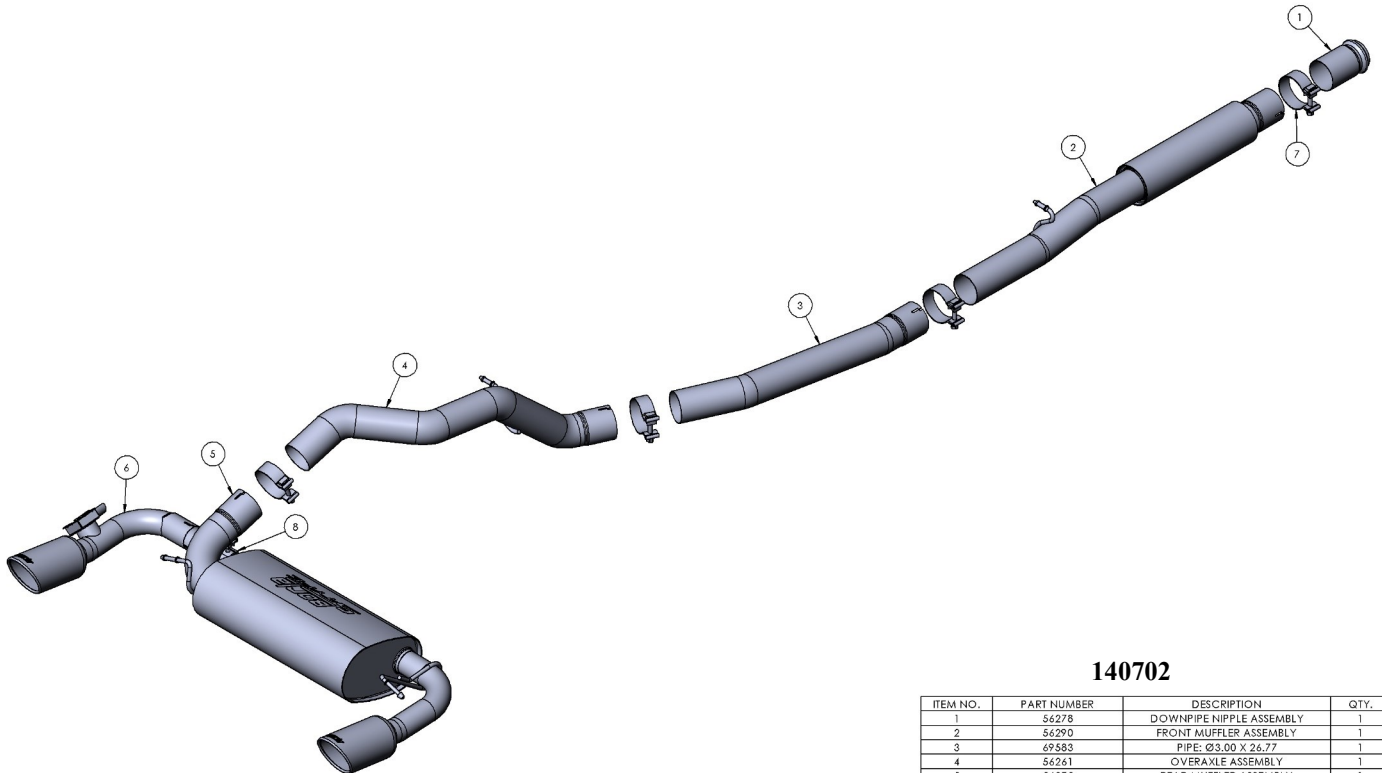

140702

ITEM NO.	PART NUMBER	DESCRIPTION	QTY.
1	56273	DOWNPIPE NIPPLE ASSEMBLY	1
2	56290	FRONT MUFFLER ASSEMBLY	1
3	69583	PIPE: Ø3.00 X 26.77	1
4	56261	OVERAXLE ASSEMBLY	1
5	56275	REAR MUFFLER ASSEMBLY	1
6	56276	L/H TAILPIPE ASSEMBLY	1
7	90114	3.00 ACCUSEAL CLAMP	4
8	90112	2.25 ACCUSEAL CLAMP	1

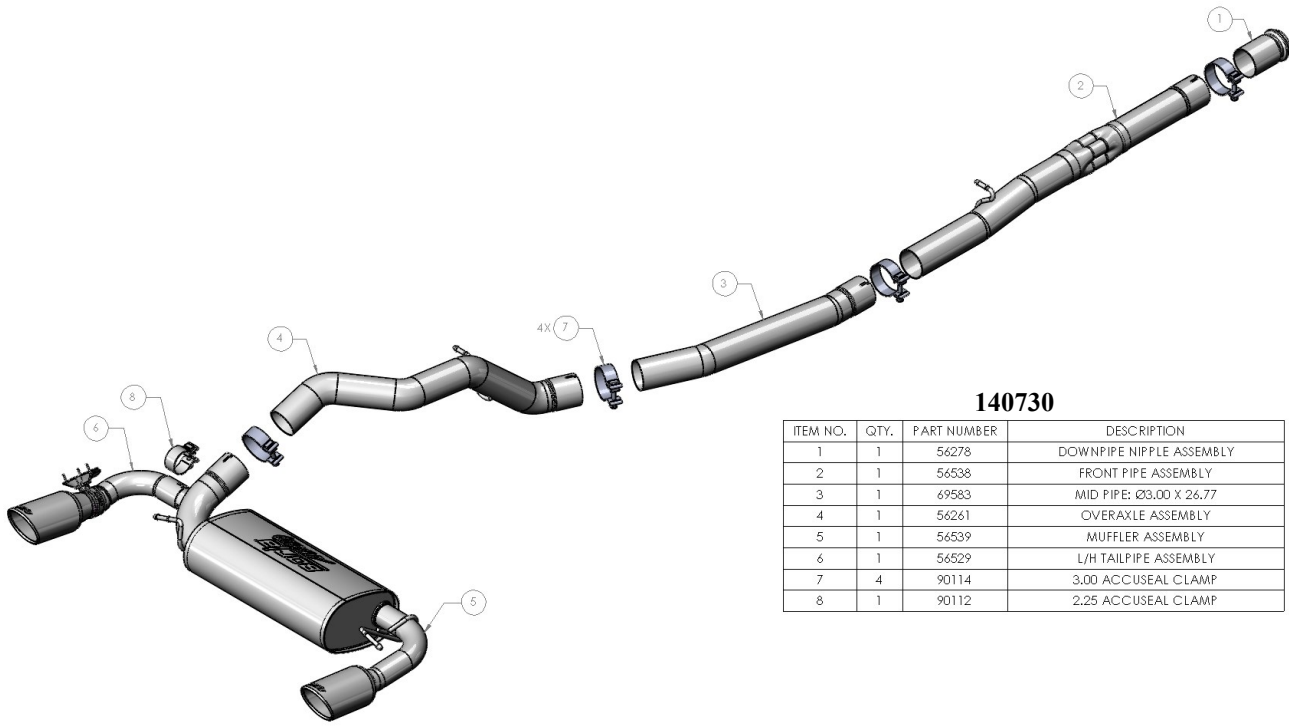

140730

ITEM NO.	QTY.	PART NUMBER	DESCRIPTION
1	1	56278	DOWNPIPE NIPPLE ASSEMBLY
2	1	56538	FRONT PIPE ASSEMBLY
3	1	69583	MID PIPE: Ø3.00 X 26.77
4	1	56261	OVERAXLE ASSEMBLY
5	1	56539	MUFFLER ASSEMBLY
6	1	56529	L/H TAILPIPE ASSEMBLY
7	4	90114	3.00 ACCUSEAL CLAMP
8	1	90112	2.25 ACCUSEAL CLAMP

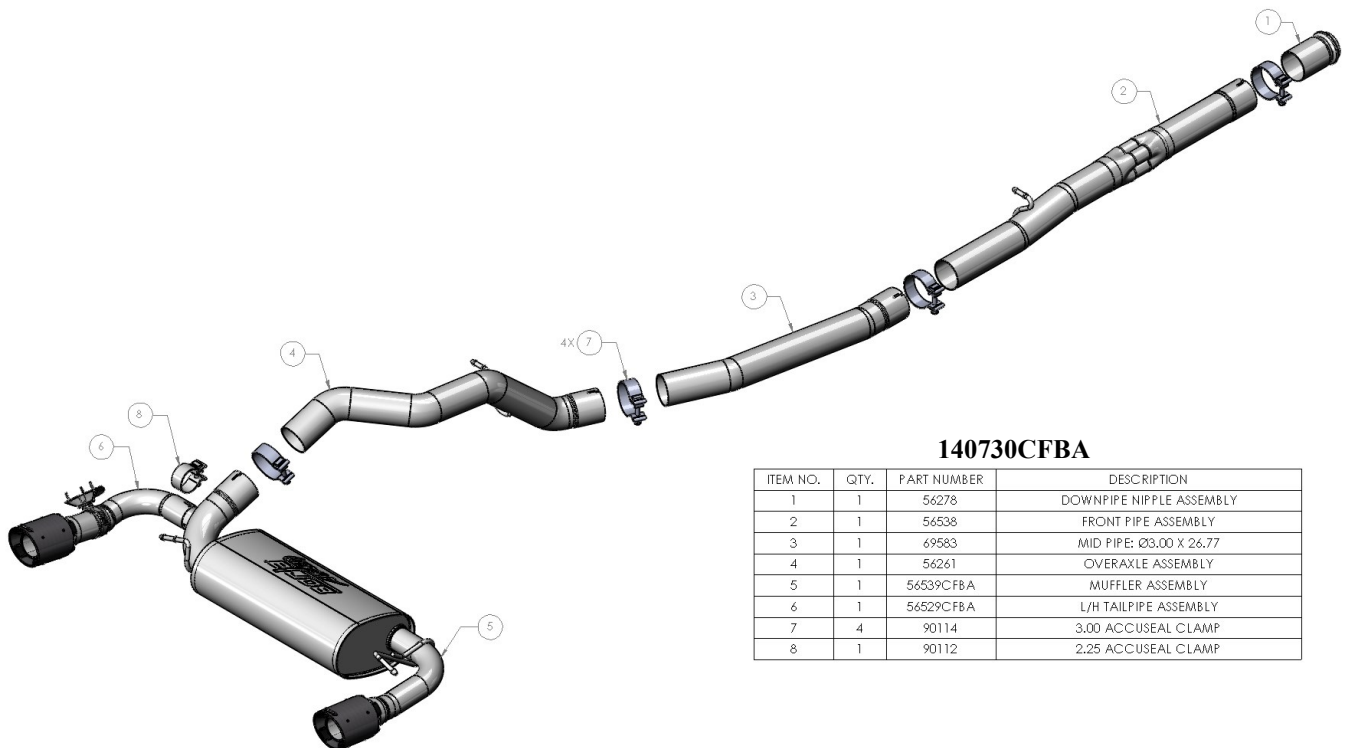

140730CFBA

ITEM NO.	QTY.	PART NUMBER	DESCRIPTION
1	1	56278	DOWNPIPE NIPPLE ASSEMBLY
2	1	56538	FRONT PIPE ASSEMBLY
3	1	69583	MID PIPE: Ø3.00 X 26.77
4	1	56261	OVERAXLE ASSEMBLY
5	1	56539CFBA	MUFFLER ASSEMBLY
6	1	56529CFBA	L/H TAILPIPE ASSEMBLY
7	4	90114	3.00 ACCUSEAL CLAMP
8	1	90112	2.25 ACCUSEAL CLAMP

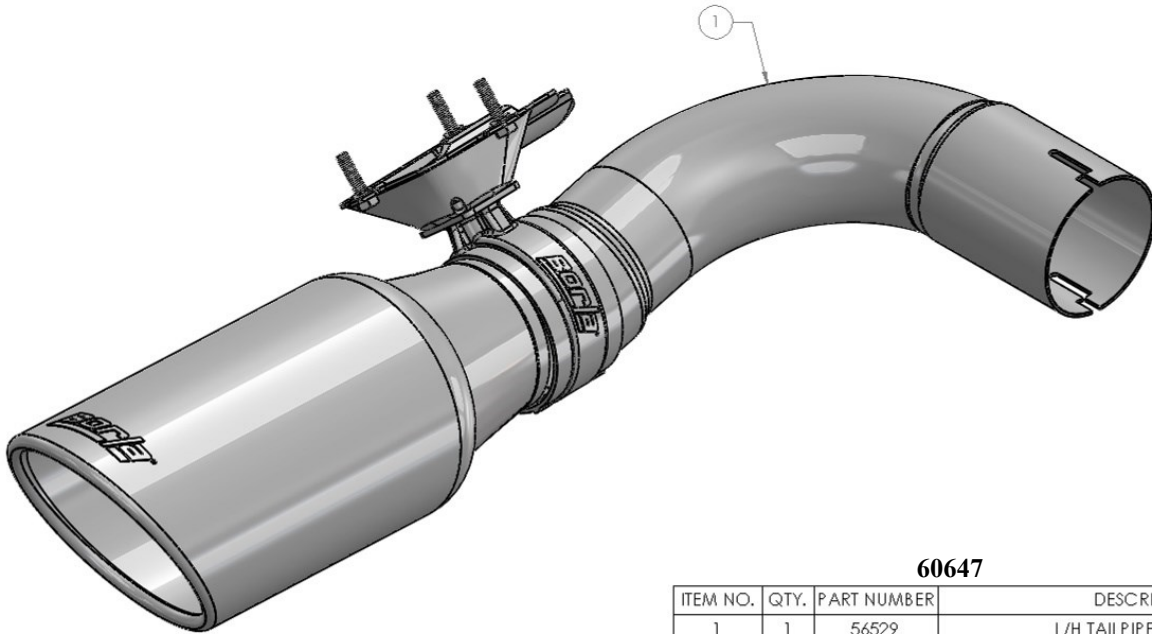

60647

ITEM NO.	QTY.	PART NUMBER	DESCRIPTION
1	1	56529	L/H TAILPIPE ASSEMBLY

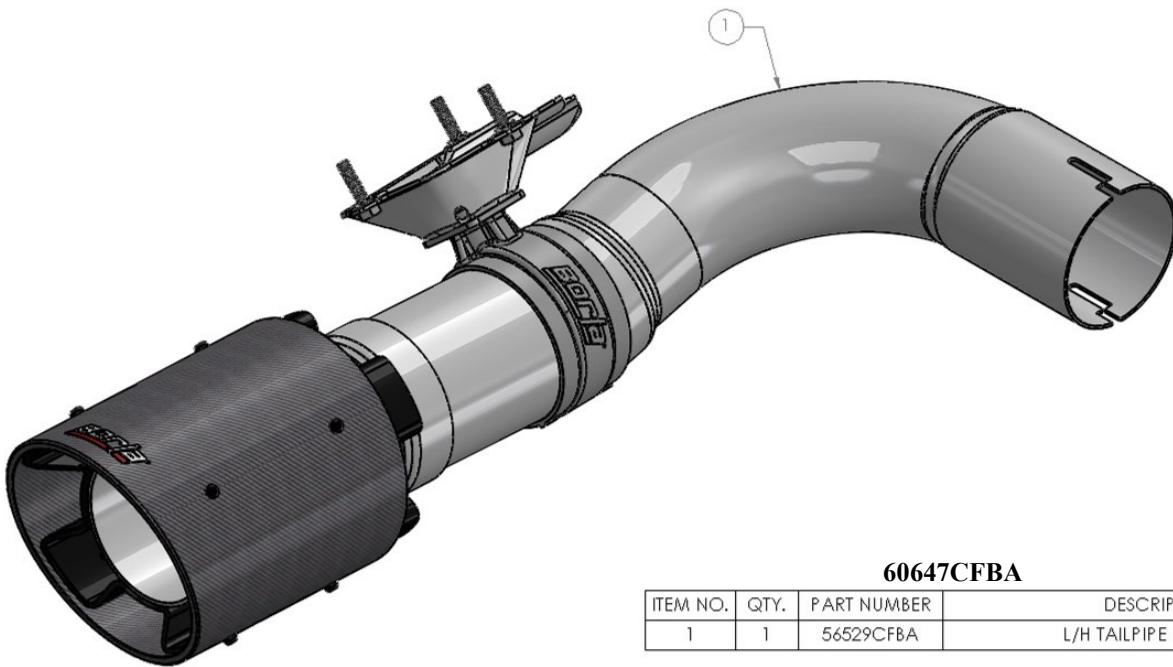

60647CFBA

ITEM NO.	QTY.	PART NUMBER	DESCRIPTION
1	1	56529CFBA	L/H TAILPIPE ASSEMBLY

Caution!!! *Never work on a hot exhaust system. Serious injury in the form of burns can result if the vehicle has been in use and the exhaust system is hot, allow vehicle to cool for at least 1 hour. Always wear eye protection when working under any vehicle.*

Note: *It is our recommendation that you use a hoist or hydraulic lift to facilitate the installation of your new Borla Performance Exhaust System.*

Taking all under car safety precautions, lift the vehicle using a hoist or hydraulic lift. Once this has been done, you may begin the removal of your old exhaust system from your vehicle.

Note: *Before removing the original exhaust system from your vehicle, please compare the parts you have received with the bill of materials provided on the previous page to assure that you have all the parts necessary for the installation of your new Borla Performance Exhaust System.*

Note: *With a used vehicle, we suggest a penetrating spray lubricant to be applied liberally to all exhaust fasteners and allowing a significant period of time for the chemical to lubricate the threads before attempting to disassemble.*

Original Exhaust System Removal

1. Disconnect the wire harness from the OE actuator on left-side of rear muffler assembly. (See Fig. 1)
2. Cut the left-side muffler inlet pipe using a metal-cutting bladed chain saw. Remove hangers from rubber isolators and remove rear muffler assembly. (See Fig. 2)
3. Using a muffler stand or an additional person to support the front pipe assembly. Loosen and remove clamp from the front pipe retaining hardware for re-installation. (See Fig. 3)
4. Carefully remove the hangers from the rubber isolators and remaining front exhaust from vehicle. (See exhaust system removed in Fig. 5)
5. Remove the electronic actuator from the OE system (which will later be transferred to your new system). (See Fig. 4)

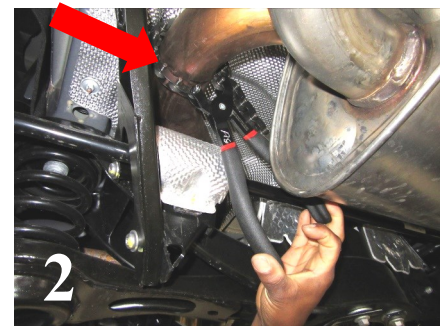

Borla Performance Cat-Back™ Exhaust System Installation



1. Reference components and layout on page 2. (See Fig. 6)
2. Install **Downpipe Nipple Assembly** to factory downpipe using factory v-band clamp.

*(NOTE: **Downpipe Nipple Assembly** is not used when this exhaust is installed to Competition-Use Borla Down Pipe PN-60631)*

3. Place a clamp over the inlet of the **Front Muffler Assembly** and insert inlet to the **Downpipe Nipple Assembly** carefully inserting the hanger into the rubber isolator. (See Fig. 7) Do not tighten the clamp.
4. Place a clamp over the expanded end of the (mid) **Pipe** and insert inlet to the **Front Muffler Assembly**. (See Fig. 8) Do not tighten the clamp.
5. Place a clamp over the expanded end of the **Over Axle Pipe Assembly** and insert inlet into the **Mid Pipe Assembly** carefully inserting hanger into the rubber isolator. (See Fig. 9 & 10) Do not tighten the clamp.

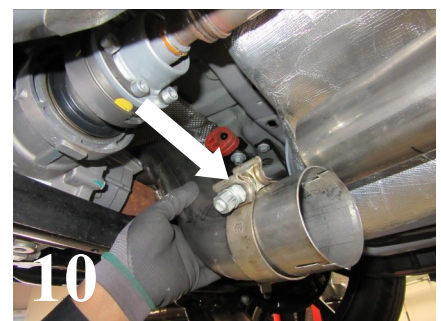
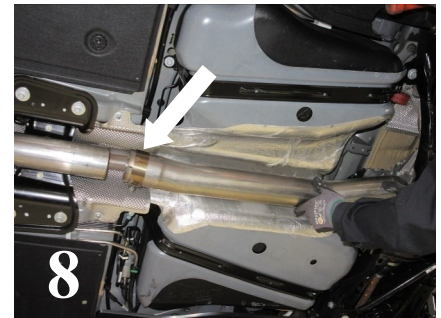
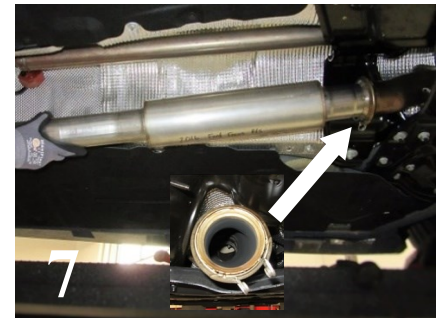

WARNING: Use extreme caution during installation. Torque all fasteners according to manufacturer's torque values and tightening sequence. **DO NOT** use air impact tools to tighten fasteners on Borla Performance Exhaust Systems. Use of such tools may result in bent flanges or gasket contact areas leading to exhaust leaks.

NOTE: When you first start your vehicle after the installation of your new Borla Performance Exhaust System, there may be some smoke and fumes coming from the system. This is a protective oil based coating used in the manufacturing of mandrel bent performance exhaust tubing. This is not a problem and will disappear within a very short period of time after the exhaust has reached normal operating temperatures.

Borla Performance Cat-Back™ Exhaust System Installation

6. Place a clamp over the expanded end of **Rear Muffler Assembly** and insert the inlet into the **Over Axle Assembly**. (See Fig.11) Do not tighten clamps.
7. Place a clamp on the expanded end of the **Rear Muffler Assembly inlet** and insert to the **Over Axle Assembly** carefully inserting two hangers into the factory rubber isolators. (See Fig. 12) Do not tighten clamps.



SELECT 8A or 8B INSTALLATION BELOW:

8A. 140702, 140730, or 140730CFBA INSTALLATION: Install the OE actuator to **L/H Tail Pipe Assembly** reusing the factory hardware. Tighten bolts to 6 ft lbs torque. (See Fig. 13)

8B. 60647 or 60647CFBA INSTALLATION: Install the OE actuator to **L/H Tail Pipe Assembly** reusing the factory hardware *carefully aligning the actuator spring to the mechanical slot of the rotating valve body*. Tighten bolts to 6 ft lbs torque. (See Fig. 13)

9. Place a clamp on the expanded end of **L/H Tail Pipe Assembly** and insert to the outlet of the **Rear Muffler Assembly**. Do not tighten clamp. Connect the wire harness to the actuator. (See Fig. 14)
10. Check your exhaust system for proper clearance under the vehicle and also for tip alignment. Starting at front flanges and moving to rear of vehicle, tighten flange hardware bolts. Orient position of bolt (on supplied clamps) between (not over) pipe notches and tighten to 35 ft. lbs. torque.
11. Align tips and tighten hardware. Loosen clamps to rotate or slide pipe for better alignment. (See Fig. 15)
12. Before starting your vehicle, make sure to check all wires, hoses, brake lines, body parts and tires for safe clearance from the exhaust system.
13. Start vehicle and check for any leaks. If any leaks are found, determine cause (such as loose or incorrectly positioned clamp) and repair as necessary.

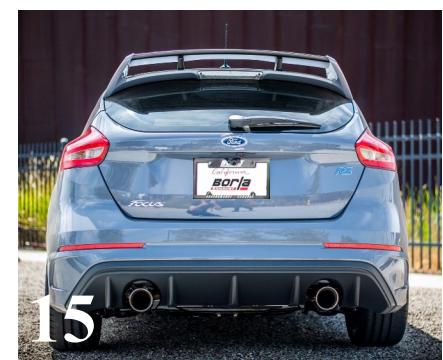
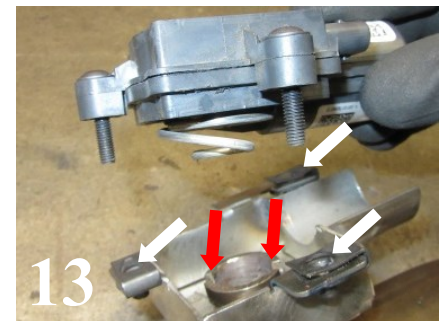
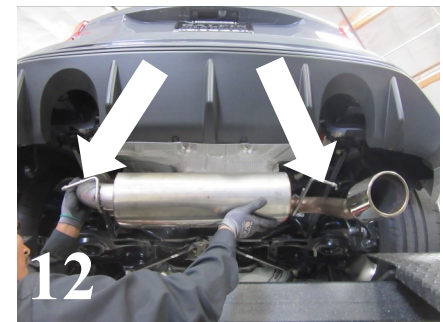

WARNING: Use extreme caution during installation. Torque all fasteners according to manufacturer's torque values and tightening sequence. **DO NOT** use air impact tools to tighten fasteners on Borla Performance Exhaust Systems. Use of such tools may result in bent flanges or gasket contact areas leading to exhaust leaks.

NOTE: When you first start your vehicle after the installation of your new Borla Performance Exhaust System, there may be some smoke and fumes coming from the system. This is a protective oil based coating used in the manufacturing of mandrel bent performance exhaust tubing. This is not a problem and will disappear within a very short period of time after the exhaust has reached normal operating temperatures.