

2015+ Mustang Phase 2 Upgrade

Installation Instructions

P/N: 1315-P2UPG



PHASE
ROUSHCHARGED **2**TM



39555 Schoolcraft Rd, Plymouth MI, 48170 | 800.59.ROUSH

2015+ Mustang Phase 2 Upgrade

Installation Instructions

P/N: 1315-P2UPG

Application: 2015-2016 Ford Mustang 5.0L

Important Note:

Before installing your ROUSH Performance Product, please read the installation manual and verify that all items are present. If you are missing hardware or have any questions, please contact ROUSH Performance at 1-800-59-ROUSH.

TABLE OF CONTENTS

Packing List for 2015+ Mustang Phase 2 Upgrade2
 Equipment and Supplies Required.....2
 Limit of Liability Statement.....3
 Safety Precautions3
 Work Safely!3
 Section A – Disassembly.....4
 Section B – Installation.....7
 PCM Flashing.....10

PACKING LIST FOR 2015+ MUSTANG PHASE 2 UPGRADE

Description	Part Number	Quantity
Roush FPVR	1315-9D370-AA	1
Intermediate Harness (FPVR to JUMPER)	1313-9A400-AA	1
Jumper Harness (FPDM TO INT HARNESS)	1315-9A340-AA	1
Self-Tapping Screw #8 x 1/2"	STS 8 x 1/2	4
Supercharger Pulley – 80 mm	1313-6K80	1
Spark Plugs – Heat Range 0, 0.9 gap	M-12405-M50	8
Voucher Card – P2	P1315-P2-AA	1

EQUIPMENT AND SUPPLIES REQUIRED

- Zip Ties
- Trim Tool
- Drill
- 1/8" Drill Bit
- 1/4" Socket
- 3/8" Drive Torque Wrench
- 1/4" Drive Torque Wrench
- 14 mm Spark Plug Socket
- 8 mm Socket

If you are missing any items, please call us toll free at 1-800-59-ROUSH.

LIMIT OF LIABILITY STATEMENT

The information contained in this publication was accurate and in effect at the time the publication was approved for printing and is subject to change without notice or liability. ROUSH Performance Products (RPP) reserves the right to revise the information presented herein or to discontinue the production of parts described at any time.

SAFETY PRECAUTIONS



CAREFULLY READ THE IMPORTANT SAFETY PRECAUTIONS and WARNINGS BEFORE PROCEEDING WITH THE INSTALLATION!

Appropriate disassembly, assembly methods and procedures are essential to ensure the personal safety of the individual performing the kit installation. Improper installation due to the failure to correctly follow these instructions could cause personal injury or death. Read each step of the installation manual carefully before starting the installation.

- Always wear safety glasses for eye protection.
- Place ignition switch in the OFF position.
- Always apply the parking brake when working on a vehicle.
- Block the front and rear tire surface to prevent unexpected vehicle movement.
- If working with a lift, always consult vehicle manual for correct lifting specifications.
- Operate the engine only in well-ventilated areas to avoid exposure to carbon monoxide.
- Do not smoke or use flammable items near or around the fuel system.
- Use chemicals and cleaners in well-ventilated areas.
- Batteries produce explosive gases, which can cause personal injury. Therefore, do not allow flames, sparks or flammable substances to come near the battery.
- Keep hands and any other objects away from the radiator fan blades.
- Keep yourself and your clothing away from moving parts when the engine is running.
- Do not wear loose clothing or jewelry that can get caught in rotating parts or scratch surface finishes.
- Allow the engine, cooling system, brakes and exhaust to cool before working on a vehicle.

WORK SAFELY!

Perform this installation on a good clean level surface for maximum safety with the engine turned off.

SECTION A – DISASSEMBLY

The following section will guide you through the preparation for the installation of your ROUSH Fuel System Upgrade Kit.

1. Disconnect the negative battery terminal.
2. Access the vehicle rear seats. Locate the rear seat bottom removal tab illustrated below (there are two [2] tabs, one on the passenger side, and one on the driver side). Remove the rear seat bottom by pushing on each plastic tab and pulling the seat bottom upward and out.



3. Disconnect the vehicle harness from the fuel pump module.



4. Remove the spare tire well cover and the emergency tire repair kit.



5. Remove the plastic taillight closeout panel (there are four [4] end caps holding the closeout panel on).

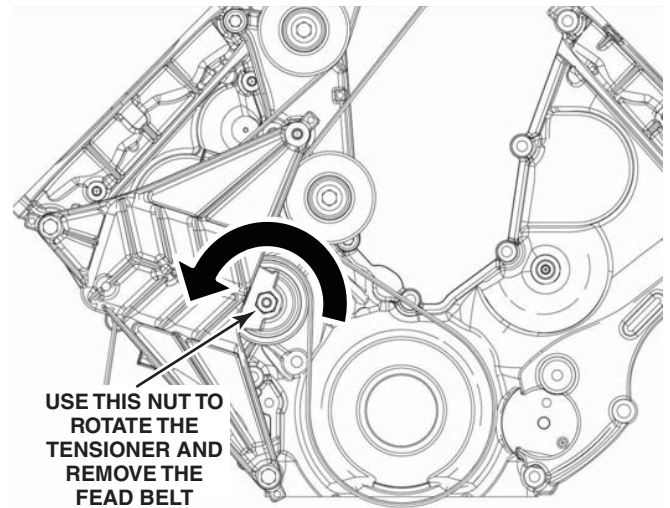

6. Remove the M6 bolts from the supercharger hub. Remove the pulley and keep the bolts since they will be reused.



8. Remove the clean air tube by loosening the clamps and disconnect the hoses attached to the tube.



7. Remove the belt from the supercharger by rotating the tensioner counterclockwise and removing the FEAD belt from the supercharger pulley.

9. Disconnect the hoses and remove the oil cap going through the coil covers.
10. Remove the coil covers by gently pulling up on them.



11. Disconnect the electrical connectors for each of the ignition coils.



12. Remove the fasteners holding the ignition coils in place.



13. Remove the ignition coils and number them so they can be reinstalled in the position from which they were removed.



14. Using a 14 mm spark plug socket and a 6" extension, remove all eight (8) spark plugs.



15. Unpack the spark plugs which are pre-gapped to 0.9 mm, ensure the gap is correct and none are damaged.



16. Install the spark plugs and torque to 14 Nm.



17. Apply a small amount of dielectric grease and reinstall the ignition coils, torquing the bolts to 6 Nm.
18. Reconnect the electrical connectors to each coil, then reinstall the coil covers, clean air tube and hoses. Torque the clamps to 3 Nm.

SECTION B – INSTALLATION

1. Using the fuel pump voltage regulator as a template, mark the four (4) mounting holes on the driver side of the spare tire wheel well as shown.



2. Using the 1/8" drill bit, drill the four (4) locations marked.



3. Using the #8 self-tapping screws, attach the fuel pump voltage regulator to the wheel well.



4. Attach the ground strap to the chassis ground of the driver side of the trunk.



5. Plug the Intermediate harness into both the factory wiring harness and the fuel pump module.



6. Run the 2-pin connector from the trunk well along the driver side panel to the fuel pump module.



7. Connect the feed to the intermediate fuel pump harness connector. Make sure the harness is pointed out of the way of the rear seat cushion.



8. Re-install the emergency tire repair kit, the taillight closeout panel and the spare tire well carpet.

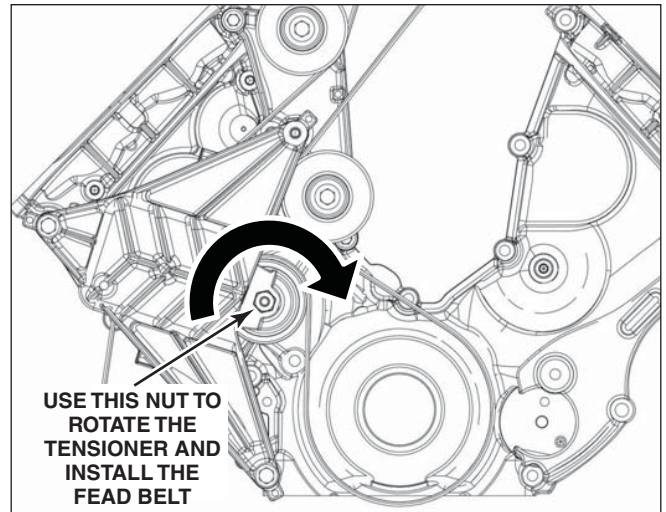

9. Install the new 80 mm supercharger pulley onto the hub of the supercharger using the six (6) M6 x 16 bolts. Apply a small amount of thread locking compound to each bolt and torque to 8-12 Nm. **NOTE:** You will need to torque the supercharger pulley bolts once the FEAD belt is installed.

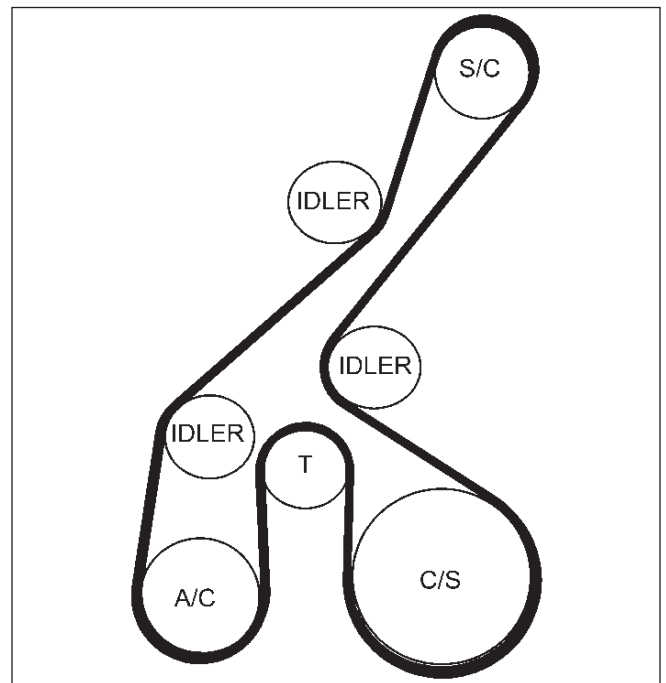

10. Re-install the FEAD belt on the supercharger by rotating the tensioner clockwise and routing the belt as shown in the routing below.

PCM Flashing

1. If equipped with a SAE J2534 pass through device, refer to the RDT-CALIM manual found on our website. The RDT-CALIM manual will guide you through the ROUSH Diagnostic Tool (RDT) software installation process and the ROUSH PCM flashing procedure. **OPERATING THE ENGINE WITHOUT THE RECALIBRATED PCM WILL RESULT IN ENGINE DAMAGE OR FAILURE AND WILL VOID THE WARRANTY.**
2. Once the PCM has been successfully recalibrated, start the engine and check for unusual noises, dash service lights, and unusual operation. If problems are detected, immediately stop the engine or vehicle, diagnose and repair the problem.

If you do not have a SAE J2534 device, you can send your PCM to Roush Performance along with the voucher card. Upon receipt, a customer service representative will contact you to arrange payment.

ATTN: PCM FLASH
39555 Schoolcraft Rd.
Plymouth, MI 48170