

# Ford 5.0L Mustang Supercharger System Installation Instructions

1986-1993 MODEL YEARS  
50 State Smog Legal per CARB EO #D-213-17  
(CARB EO # not applicable to Renegade Kit P/N: 4FA218-100/108)

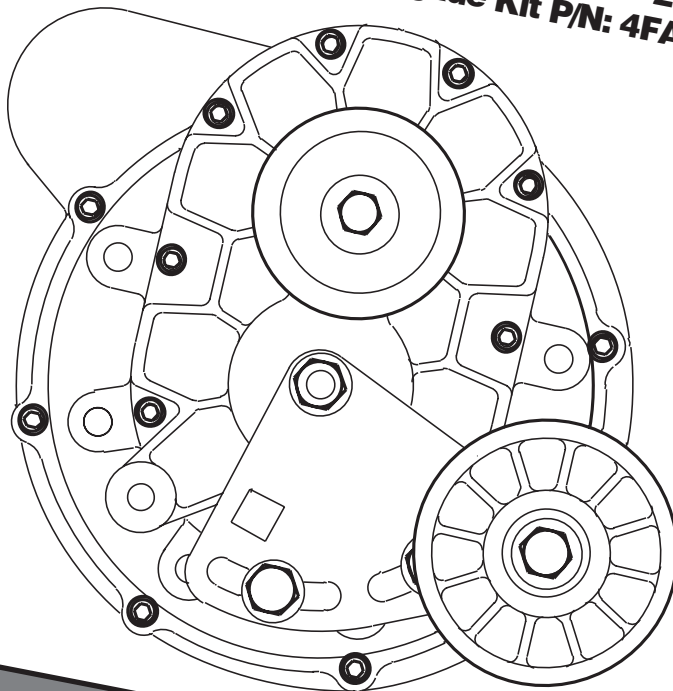

ENGINEERING, LLC

1650 PACIFIC AVENUE • CHANNEL ISLANDS, CA 93033-9901 • (805) 247-0226  
FAX (805) 247-0669 • [www.vortechsuperchargers.com](http://www.vortechsuperchargers.com) • M-F 8:00 AM - 4:30 PM PST

# FOREWORD

**T**his manual provides information on the installation, maintenance and service of the Vortech supercharger kit expressly designed for this vehicle. All information, illustrations and specifications contained herein are based on the latest product information available at the time of this publication. Changes to the manual may be made at any time without notice. Contact Vortech Engineering for any additional information regarding this kit and any of these modifications at (805) 247-0228 8:00am-4:30pm PST.

## Take note of the following before proceeding:



1. Proper installation of this supercharger kit requires general automotive mechanic knowledge and experience. Please browse through each step of this instruction manual prior to beginning the installation to determine if you should refer the job to a professional installer/technician. Please contact your dealer or Vortech Engineering for possible installers in your area.
2. This product was designed for use on stock (un-modified, OEM) vehicles. The PCM (computer), engine, transmission, drive axle ratios and tire O.D. must be stock. If the vehicle or engine has been modified in any way, check with Vortech prior to installation and use of this product.
3. Use only premium grade fuel with a minimum of 91 octane (R+M/2).
4. Always listen for any sign of detonation (knocking/pinging) and discontinue hard use (no boost) until problem is resolved.
5. Vortech is not responsible for any clutch, transmission, drive-line or engine damage.

Exclusions from Vortech warranty coverage considerations include, but not limited to:

1. Neglect, abuse, lack of maintenance, abnormal operation or improper installation.
2. Continued operation with an impaired vehicle or sub-system.
3. The combined use of Vortech components with other modifications such as, but not limited to, exhaust headers, aftermarket camshafts, nitrous oxide, third party PCM programming or other such changes.

**©2008 VORTECH ENGINEERING, LLC**

All rights reserved. No part of this publication may be reproduced, transmitted, transcribed, or translated into another language in any form, by any means without written permission of Vortech Engineering, LLC.

# TABLE OF CONTENTS

FOREWORD.....	ii
TABLE OF CONTENTS.....	iii
IMPORTANT NOTICE .....	iv
TOOL & SUPPLY REQUIREMENT .....	v
PARTS LIST - 1986-1993 MUSTANG .....	vi
PARTS LIST - 1993 MUSTANG COBRA.....	vii
PARTS LIST - 1986-1993 HIGH-OUTPUT MUSTANG.....	viii
PARTS LIST - 1986-1993 HIGH-OUTPUT MUSTANG (Internally Lubricated).....	ix
PARTS LIST - 1986-1993 RENEGADE MUSTANG.....	x
PARTS LIST - 1986-1993 SUPER HIGH-OUTPUT MUSTANG .....	xi
MSD IGNITION SYSTEM .....	xiii
1. PREPARATION/REMOVAL.....	1
2. CRANKSHAFT PULLEY.....	1
3. OIL DRAIN.....	2
4. OIL FEED LINE.....	2
5. FUEL MANAGEMENT UNIT .....	3
6. T-REX FUEL PUMP (High Output and Cobra Systems Only).....	4
7. MAIN BRACKET ASSEMBLY .....	7
8. SMOG PUMP HOSES.....	8
9. RADIATOR HOSE .....	9
10. ACCESSORY BELT TENSIONER MOUNTING BRACKET.....	9
11. SUPERCHARGER MOUNTING .....	10
12. SUPERCHARGER DRIVE BELT .....	10
13. AIR FILTER ASSEMBLY .....	11
14. IGNITION/BOOST CONTROL INSTALLATION .....	11
15. IGNITION/BOOST CONTROL UNIT OPERATION.....	12
16. VORTECH BYPASS VALVE (High Output and Cobra Systems Only).....	13

# NOTICE

This product is protected by state common law, copyright and/or patent. All legal rights therein are reserved. The design, layout, dimensions, geometry, and engineering features shown in this product are the exclusive property of Vortech Engineering, Inc. This product may not be copied or duplicated in whole or part, abstractly or fundamentally, intentionally or fortuitously, nor shall any design, dimension, or other information be incorporated into any product or apparatus without prior written consent of Vortech Engineering, LLC.

---

This Vortech 5.0 supercharger kit was designed for installation and use on Mass Air Flow (MAF) equipped vehicles. The model years include 1988 California and all 1989-1993 models. All other years not equipped with MAF systems (factory or aftermarket) require the installation of a MAP sensor check valve assembly (Vortech part number 4FD113-010). This allows proper function of early (1986-1988) models equipped with speed density processors.

---

## RENEGADE 5.0L KIT

The factory water pump pulley may require removal and replacement with an aftermarket unit for proper supercharger drive belt clearance. Also, an aftermarket electric fan is recommended, although the factory mechanical fan may still be retained with minor clearance modifications.

# 1986 - 1993 FORD 5.0L MUSTANG Installation Instructions

50 State Smog Legal, as per CARB EO #D-213-17 (not applicable to P/N: 4FA218-100/108)  
Congratulations on selecting the best performing and best backed automotive supercharger available today... the VORTECH® supercharger!

Before beginning this installation, please read through this entire instruction booklet and the Street Supercharger System Owner's Manual (Race Owner's Manual for the Renegade kit) which includes the Limited Warranty Program, the Warranty Registration form and return envelope.

## 1986-93 RENEGADE 5.0L MUSTANG KIT ONLY 4FA218-100/108

**IMPORTANT NOTE:** This kit does not supply any of the required fuel and ignition system support assemblies. This kit was designed for racing/off-road use only.

**IGNITION:** An ignition amplification unit will be required above 10 psig manifold pressure. Crane HI-6/7 or MSD 6/7 are the most popular choices. A high output coil is also suggested. Spiral core, low resistance, suppression spark plug wires will also be required. Vortech part number 5A002-005 is a 10.4mm premium wire set manufactured by Taylor, with pre-cut lengths for the 5.0 Mustang.

**FUEL SYSTEM:** A high output fuel system will be required when horsepower levels reach approximately 400 or above. Vortech produces a variety of fuel system combinations including the Maxflow Renegade system which is a complete fuel system from the tank pickup to the fuel rails and will support up to 1000 hp (wiring harness is included).

Vortech supercharger systems are performance improving devices. In most cases, increases in torque of 30-35% and horsepower between 35-45% can be expected with the boost levels specified by Vortech Engineering. This product is intended for use on healthy, well maintained engines. Installation on a worn-out or damaged engine is not recommended and may result in failure of the engine as well as the supercharger. Vortech Engineering is not responsible for engine damage.

Installation on new vehicles will not harm or adversely affect the break-in period so long as factory break-in procedures are followed.

For best performance and continued durability, please take note of the following key points:

1. Use only premium grade fuel 91 octane or higher (R+M/2).
2. The engine must have stock compression ratio.
3. If the engine has been modified in any way, check with Vortech prior to using this product.
4. Always listen for any sign of detonation (pinging) and discontinue hard use (no boost) until problem is resolved.
5. Perform an oil and filter change upon completion of this installation and prior to test driving your vehicle. Thereafter, always use a high grade SF rated engine oil or a high quality synthetic, and change the oil and filter at least every 3,000 miles. Never attempt to extend the oil change interval beyond 3,000 miles, regardless of oil manufacturer's claims as potential damage to the supercharger may result.
6. Before beginning installation, replace all spark plugs that are older than 1 year or 10,000 miles with original heat range plugs as specified by the manufacturer and reset timing to factory specifications (follow the procedures indicated within the factory repair manual and/or as indicated on the factory underhood emissions tag). Do not use platinum spark plugs unless they are original equipment. Change spark plugs every 15,000 miles and spark plug wires at least every 50,000 miles.

## TOOL & SUPPLY REQUIREMENT

- Factory repair manual
- Timing light
- 3/8" socket and drive set: SAE & metric
- 1/2" socket and drive set: SAE & metric
- 1/2" breaker bar and 4" extension
- 1/8" NPT tap, 3/8" NPT tap, 3/8-16 tap & handle
- Adjustable wrench
- Open end wrenches: 3/8", 7/16", 1/2", 9/16"
- "Slimline" 19 mm - Snap-On #LTAM1719
- Center punch and a 5/8" tapered punch
- Ford springlock 3/8" fuel fitting disconnect tool
- 5 quarts SF rated quality engine oil, oil filter and wrench
- Large screwdriver or pry bar
- Flat #2 screwdriver
- Phillips #2 screwdriver
- Heavy grease
- Silicone sealer
- Drill motor
- 3/32", R or 5/16", 7/16" drill bits

If it has been 10,000 miles or more since your vehicle's last spark plug change, then you will also need:

- Spark plug socket
- NEW spark plugs

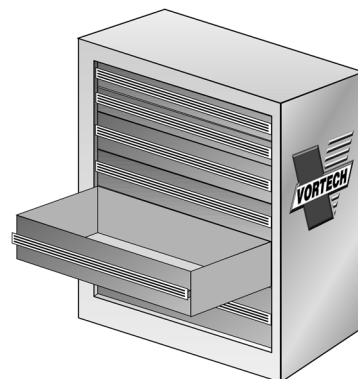



# 1986-1993 Mustang

## Part No. 4FA218-010

# PARTS LIST

**IMPORTANT: Before beginning installation, verify that all parts are included in the kit. Report any shortages or damaged parts immediately.**

PART NUMBER	DESCRIPTION	QUANTITY	PART NUMBER	DESCRIPTION	QUANTITY
<b>2A228-100</b>	<b>V-1 SUPERCHARGER ASSEMBLY</b>	<b>1</b>	<b>4FA110-011</b>	<b>SPRING TENSIONER</b>	<b>1</b>
<b>4FA111-032</b>	<b>SUPERCHARGER BELT TENSIONER ASSEMBLY</b>	<b>1</b>		<b>MOUNTING ASSEMBLY</b>	
7J012-092	12mm FLAT WASHERS	3	4FA010-011	TENSIONER MOUNTING BRACKET	1
4FA011-032	BELT TENSIONER PLATE	1	7A375-100	3/8-16 x 1" BOLTS	2
7C012-050	12mm x 1.75" x 50mm BOLT	1	7J375-044	3/8"SAE WASHERS	3
4FA016-150	SMOOTH PULLEY TENSIONER	1	7F375-016	3/8-16 NUT	1
2A017-010	IDLER PULLEY SPACER	1	7A500-350	1/2-13 x 3-1/2" CARRIAGE BOLT	1
7C012-020	12mm x 1.75" x 20mm BOLTS	2	7F500-013	1/2-13 NUT	1
7C012-022	12mm x 1.75" x 22mm THIN HEAD BOLT	1	7J012-092	12mm FLAT WASHER	1
7G010-175	12mm x 1.75" NUT	1	<b>4FA114-023</b>	<b>RADIATOR HOSE ASSEMBLY</b>	<b>1</b>
<b>4FA112-010</b>	<b>AIR INTAKE ASSEMBLY</b>	<b>1</b>	4FA014-011	RADIATOR PIPE	1
7S350-200	3-1/2" x 2" SLEEVE	1	7R002-024	#24 HOSE CLAMPS	2
4FA012-012	90° INTAKE ELBOW	1	<b>4FA111-021</b>	<b>MOUNTING BRACKET ASSEMBLY</b>	<b>1</b>
4FA013-010	AIR CLEANER COVER	1	4FA011-021	MOUNTING BRACKET	1
7J006-093	6mm WASHERS	2	4FA010-034	MOUNTING PLATE	1
7P375-097	3/8"NPT x 3/8" BARB	1	4FA015-015	ALTERNATOR STAY	1
7S300-100	3" x 1" SLEEVE	1	4FA017-021	SMOG PUMP SPACER	1
7E010-046	#8 x 3/4" SHEET METAL SCREWS	2	7A375-625	3/8-16 x 6-1/4" BOLTS	2
8H040-010	AIR FILTER	1	7A375-700	3/8-16 x 7" BOLT	1
7R002-056	#56 HOSE CLAMPS	2	7A437-175	7/16-14 x 1-3/4" BOLT	1
7R002-052	#52 HOSE CLAMPS	2	7A375-175	3/8-16 x 1-3/4" BOLT	1
7U035-000	3-1/2" x 12" FLEX HOSE	1	7A375-650	3/8-16 x 6-1/2" BOLT	1
<b>4FA112-020</b>	<b>AIR DISCHARGE ASSEMBLY</b>	<b>1</b>	7A375-200	3/8-16 x 2" BOLT	1
4FA012-020	DISCHARGE TUBE	1	7A375-075	3/8-16 x 3/4" BOLT	1
7S275-200	2-3/4" x 2" SLEEVE	1	7F375-016	3/8-16 NUTS	2
7S300-200	3" x 2" SLEEVE	1	7A375-100	3/8-16 x 1" BOLTS	7
7R002-044	#44 HOSE CLAMPS	2	7K375-040	3/8"AN960 FLAT WASHERS	5
7R002-048	#48 HOSE CLAMPS	2	7J375-044	3/8"SAE WASHERS	10
<b>4FA139-096</b>	<b>PCV BYPASS KIT</b>	<b>1</b>	7J012-092	12mm FLAT WASHER	1
8H040-020	3/8" INLINE FILTER	1	<b>4FA130-026</b>	<b>OIL FEED ASSEMBLY</b>	<b>1</b>
7U375-052	3/8" VACUUM CAP	1	7P525-067	.500" CRIMP FERRULES	2
7U030-056	3/8" x 22" FUEL HOSE	1	7P250-066	#4 SWIVEL x 1/4" HOSE BARB FITTING	2
<b>4FA238-068</b>	<b>FMU (WITH LINES)</b>	<b>1</b>	7P125-027	1/8"NPT STRAIGHT FITTING	1
6Z110-111	12:1 BLACK FUEL MANAGEMENT UNIT	1	7P125-103	1/8"NPT -4 x 45° MALE ELBOW	1
4FA145-010	MALE FUEL LINE ASSEMBLY	1	7U030-026	1/4" x 25" OIL FEED HOSE	1
4FA145-020	FEMALE FUEL LINE ASSEMBLY	1	7P250-121	3" NIPPLE	1
7U030-046	5/32" x 54" VACUUM LINE	1	7P250-122	1/4" TEE	1
7E010-046	#8 x 3/4" SHEET METAL SCREWS	2	7P250-075	45° ELBOW	1
7U100-055	6" NYLON TIE WRAPS	2	7P250-082	90° FLARE	1
<b>4FA130-036</b>	<b>OIL DRAIN ASSEMBLY</b>	<b>1</b>	<b>4FA116-011</b>	<b>CRANK PULLEY ASSEMBLY</b>	<b>1</b>
7R001-008	#8 STAINLESS HOSE CLAMPS	2	4FA016-011	6" CRANK PULLEY	1
7P375-017	3/8"NPT x 1/2" STRAIGHT HOSE BARB	1	7A375-208	3/8-16 x 2" CAP SCREWS	4
7U030-036	1/2" x 28" OIL DRAIN HOSE	1	7J375-044	3/8"SAE WASHERS	4
			2A046-527	BELT	1





ENGINEERING, LLC

# 1993 Mustang Cobra

## Part No. 4FA218-030SQ

# PARTS LIST

**IMPORTANT: Before beginning installation, verify that all parts are included in the kit. Report any shortages or damaged parts immediately.**

PART NUMBER	DESCRIPTION	QUANTITY	PART NUMBER	DESCRIPTION	QUANTITY
<b>2E428-010</b>	<b>SUPERCHARGER ASSEMBLY</b>	<b>1</b>	<b>4FA130-036</b>	<b>OIL DRAIN ASSEMBLY</b>	<b>1</b>
2E128-010	V-2 SUPERCHARGER	1	7R001-008	#8 STAINLESS HOSE CLAMPS	2
2A038-333	8-GR 3.33" SUPERCHARGER DRIVE PULLEY	1	7P375-017	3/8"NPT x 1/2" STRAIGHT HOSE BARB	1
8R101-002	8 AND 10-RIB PULLEY RETAINER ASSEMBLY	1	7U030-036	1/2" x 28" OIL DRAIN HOSE	1
<b>4FA111-021</b>	<b>MOUNTING BRACKET ASSEMBLY</b>	<b>1</b>	<b>4FA139-096</b>	<b>PCV BYPASS KIT</b>	<b>1</b>
4FA011-021	MOUNTING BRACKET	1	8H040-020	3/8" INLINE FILTER	1
4FA010-034	MOUNTING PLATE	1	7U375-052	3/8" VACUUM CAP	1
4FA015-015	ALTERNATOR STAY	1	7U030-056	3/8" x 22" FUEL HOSE	1
4FA017-021	SMOG PUMP SPACER	1	<b>4FA114-023</b>	<b>RADIATOR HOSE ASSEMBLY</b>	<b>1</b>
7A375-625	3/8-16 x 6-1/4" BOLTS	2	4FA014-011	RADIATOR PIPE	1
7A375-700	3/8-16 x 7" BOLT	1	7R002-024	#24 HOSE CLAMPS	2
7A437-175	7/16-14 x 1-3/4" BOLT	1	<b>5A101-001</b>	<b>STAND ALONE ASSEMBLY</b>	<b>1</b>
7A375-175	3/8-16 x 1-3/4" BOLT	1	7P156-082	5/32" TEE	1
7A375-650	3/8-16 x 6-1/2" BOLT	1	5A002-002	FORD EFI WIRING HARNESS	1
7A375-200	3/8-16 x 2" BOLT	1	5A001-001	STAND ALONE IGNITION RETARD	1
7A375-075	3/8-16 x 3/4" BOLT	1	7U030-046	5/32" x 24" VACUUM LINE	1
7F375-016	3/8-16 NUTS	2	<b>4FA112-030</b>	<b>DISCHARGE ASSEMBLY</b>	<b>1</b>
7A375-100	3/8-16 x 1" BOLTS	7	4FA012-030	ALUMINUM DISCHARGE TUBE	1
7K375-040	3/8"AN960 FLAT WASHERS	5	7S275-200	2-3/4" x 2" SLEEVE	1
7J375-044	3/8"SAE WASHERS	10	7S300-200	3" x 2" SLEEVE	1
7J012-092	12mm FLAT WASHER	1	7R002-044	#44 HOSE CLAMPS	2
<b>4FA110-011</b>	<b>SPRING TENSIONER MOUNTING ASSEMBLY</b>	<b>1</b>	7R002-048	#48 HOSE CLAMPS	2
4FA010-011	TENSIONER MOUNTING BRACKET	1	8D001-001	BYPASS VALVE	1
7A375-100	3/8-16 x 1" BOLTS	2	7P750-100	3/4"NPT x 1" STRAIGHT HOSE FITTING	1
7J375-044	3/8"SAE WASHERS	2	7U134-145	1" x 4-1/2" HEATER HOSE	1
7F375-016	3/8-16 NUT	1	7U134-130	1" x 3" HEATER HOSE	1
7A500-350	1/2-13 x 3-1/2" CARRIAGE BOLT	1	7R002-016	#16 HOSE CLAMPS	4
7F500-013	1/2-13 HEX NUT	1	7P156-082	5/32" TEE	1
7J012-092	12mm FLAT WASHER	1	7U030-046	5/32" x 24" VACUUM LINE	1
<b>4FA111-042</b>	<b>SUPERCHARGER BELT TENSIONER ASSEMBLY</b>	<b>1</b>	<b>4FA112-015</b>	<b>AIR INTAKE ASSEMBLY</b>	<b>1</b>
7J012-092	12mm FLAT WASHERS	3	7S350-200	3-1/2" x 2" SLEEVE	1
4FA011-032	BELT TENSIONER PLATE	1	4FA012-013	90° INTAKE ELBOW	1
7C012-020	12mm x 1.75" x 20mm BOLTS	3	4FA013-010	AIR CLEANER COVER	1
7G010-175	12mm x 1.75" NUT	1	8H040-040	AIR FILTER	1
4FA016-170	WIDE IDLER PULLEY	1	7J006-093	6mm WASHERS	2
2A017-011	8-RIB IDLER SPACER	1	7P375-097	3/8"NPT x 3/8" BARB	1
7C012-065	12mm x 1.75" x 65mm BOLT	1	7S300-100	3" x 1" SLEEVE	1
<b>4FA116-031</b>	<b>CRANK PULLEY ASSEMBLY</b>	<b>1</b>	7E010-046	#8 X 3/4" SHEET METAL SCREWS	2
4FA018-022	8 GROOVE 4.75/6.87 CRANK PULLEY	1	7R002-056	#56 HOSE CLAMPS	2
7A375-178	3/8-16 x 1-3/4" BOLTS	4	7U035-000	3-1/2" x 12" FLEX HOSE	1
7J375-044	3/8"SAE WASHERS	4	7R002-052	#52 HOSE CLAMPS	2
7L375-075	3/8" LOCK WASHERS	4	7P750-102	3/4"NPT x 1" 90° HOSE FITTING	1
2A048-545	BELT	1	<b>8F201-265</b>	<b>T-REX® PUMP ASSEMBLY</b>	<b>1</b>
<b>4FA238-078</b>	<b>FMU (WITH LINES)</b>	<b>1</b>	7F008-032	8-32 HEX LOCK NUTS	8
6Z110-112	10:1 BLACK FUEL MANAGEMENT UNIT	1	7J008-001	#8 FLAT WASHERS	8
4FA145-010	MALE FUEL ASSEMBLY	1	7P312-003	5/16" FEMALE FUEL CONNECTORS	2
4FA145-020	FEMALE FUEL LINE ASSEMBLY	1	7P312-001	FORD FUEL FITTING ADAPTER	1
7U030-046	5/32" x 54" VACUUM LINE	1	7R004-002	17.0 STEPLESS CLAMPS	2
7E010-046	#8 x 3/4" SHEET METAL SCREWS	2	7R004-001	15.7 STEPLESS CLAMPS	3
7U100-055	6" NYLON TIE-WRAPPS	2	7R001-004	#4 HOSE CLAMPS	2
<b>4FA130-026</b>	<b>OIL FEED ASSEMBLY</b>	<b>1</b>	7U314-001	#8 LORD MOUNTS	4
7P525-067	.500" CRIMP FERRULES	2	5W001-001	WIRE TAP	1
7P250-066	#4 SWIVEL x 1/4" HOSE BARB FITTINGS	2	7U032-016	3/8" x 6" FUEL HOSE	1
7P125-027	1/8" STRAIGHT FITTING	1	7E010-050	#12 x 1/2" SHEET METAL SCREW	1
7P125-103	1/8"NPT -4 x 45° MALE ELBOW	1	7U375-135	ADHESIVE MOUNTING PADS	4
7U030-026	1/4" x 25" OIL FEED HOSE	1	7U100-055	6" NYLON TIE WRAPS	6
7P250-121	3" NIPPLE	1	4FA020-030	T-REX PUMP TEMPLATE	1
7P250-122	1/4" TEE	1	8F101-200	T-REX WIRING ASSEMBLY	1
7P250-075	45° ELBOW	1	7U031-018	5/16" x 24 HP FUEL HOSE	1
7P250-082	90° FLARE	1	8F002-265	90° T-REX INLINE FUEL PUMP	1
			5W001-010	16-14GA FEMALE SLIDE	1
			5W001-002	FUSE TAP	1
			5W001-011	16-14GA EYELETS	2
			7U100-044	4" NYLON TIE-WRAPPS	4
			7U031-018	5/16" x 30" MPI HOSE	1



# 1986-1993 High-Output Mustang

## Part No. 4FA218-040SQ

# PARTS LIST

**IMPORTANT: Before beginning installation, verify that all parts are included in the kit. Report any shortages or damaged parts immediately.**

PART NUMBER	DESCRIPTION	QUANTITY	PART NUMBER	DESCRIPTION	QUANTITY
<b>2E428-010</b>	<b>SUPERCHARGER ASSEMBLY</b>	<b>1</b>	<b>4FA130-036</b>	<b>OIL DRAIN ASSEMBLY</b>	<b>1</b>
2E128-010	V-2 SUPERCHARGER	1	7R001-008	#8 STAINLESS HOSE CLAMPS	2
2E038-333	8-GR 3.33" SUPERCHARGER DRIVE PULLEY	1	7P375-017	3/8"NPT x 1/2" STRAIGHT HOSE BARB	1
8R101-002	8 & 10-RIB PULLEY RETAINER ASSEMBLY	1	7U030-036	1/2" x 28" OIL DRAIN HOSE	1
<b>4FA111-021</b>	<b>MOUNTING BRACKET ASSEMBLY</b>	<b>1</b>	<b>4FA139-096</b>	<b>PCV BYPASS KIT</b>	<b>1</b>
4FA011-021	MOUNTING BRACKET	1	8H040-020	3/8" INLINE FILTER	1
4FA010-034	MOUNTING PLATE	1	7U375-052	3/8" VACUUM CAP	1
4FA015-015	ALTERNATOR STAY	1	7U030-056	3/8" x 22" FUEL HOSE	1
4FA017-021	SMOG PUMP SPACER	1	<b>4FA114-023</b>	<b>RADIATOR HOSE ASSEMBLY</b>	<b>1</b>
7A375-625	3/8-16 x 6-1/4" BOLTS	2	4FA014-011	RADIATOR PIPE	1
7A375-700	3/8-16 x 7" BOLT	1	7R002-024	#24 HOSE CLAMPS	2
7A437-175	7/16-14 x 1-3/4" BOLT	1	<b>5A101-001</b>	<b>STAND ALONE ASSEMBLY</b>	<b>1</b>
7A375-175	3/8-16 x 1-3/4" BOLT	1	7P156-082	5/32" TEE	1
7A375-650	3/8-16 x 6-1/2" BOLT	1	5A002-002	FORD EFI WIRING HARNESS	1
7A375-200	3/8-16 x 2" BOLT	1	5A001-001	STAND ALONE IGNITION RETARD	1
7A375-075	3/8-16 x 3/4" BOLT	1	7U030-046	5/32" x 24" VACUUM LINE	1
7F375-016	3/8-16 NUTS	2	<b>4FA112-030</b>	<b>DISCHARGE ASSEMBLY</b>	<b>1</b>
7A375-100	3/8-16 x 1" BOLTS	7	4FA012-030	ALUMINUM DISCHARGE TUBE	1
7K375-040	3/8" AN960 FLAT WASHERS	5	7S275-200	2-3/4" x 2" SLEEVE	1
7J375-044	3/8" SAE WASHERS	10	7S300-200	3" x 2" SLEEVE	1
7J012-092	12mm FLAT WASHER	1	7R002-044	#44 HOSE CLAMPS	2
<b>4FA110-011</b>	<b>SPRING TENSIONER MOUNTING ASSEMBLY</b>	<b>1</b>	7R002-048	#48 HOSE CLAMPS	2
4FA010-011	TENSIONER MOUNTING BRACKET	1	8D001-001	BYPASS VALVE	1
7A375-100	3/8-16 x 1" BOLTS	2	7P750-100	3/4"NPT x 1" STRAIGHT HOSE FITTING	1
7J375-044	3/8" SAE WASHERS	2	7U134-145	1" x 4-1/2" HEATER HOSE	1
7F375-016	3/8-16 NUT	1	7U134-130	1" x 3" HEATER HOSE	1
7A500-350	1/2-13 x 3-1/2" CARRIAGE BOLT	1	7R002-016	#16 HOSE CLAMPS	4
7F500-013	1/2-13 HEX NUT	1	7P156-082	5/32" TEE	1
7J012-092	12mm FLAT WASHER	1	7U030-046	5/32" x 24" VACUUM LINE	1
<b>4FA111-042</b>	<b>SUPERCHARGER BELT TENSIONER ASSEMBLY</b>	<b>1</b>	<b>4FA112-015</b>	<b>AIR INTAKE ASSEMBLY</b>	<b>1</b>
7J012-092	12mm FLAT WASHERS	3	7S350-200	3-1/2" x 2" SLEEVE	1
4FA011-032	BELT TENSIONER PLATE	1	4FA012-013	90° INTAKE ELBOW	1
7C012-020	12mm x 1.75" x 20mm BOLTS	3	4FA013-010	AIR CLEANER COVER	1
7G010-175	12mm x 1.75" NUT	1	8H040-040	AIR FILTER	1
4FA016-170	WIDE IDLER PULLEY	1	7J006-093	6mm WASHERS	2
2A017-011	8-RIB IDLER SPACER	1	7P375-097	3/8"NPT x 3/8" BARB	1
7C012-065	12mm x 1.75" x 65mm BOLT	1	7S300-100	3" x 1" SLEEVE	1
<b>4FA116-041</b>	<b>CRANK PULLEY ASSEMBLY</b>	<b>1</b>	7E010-046	#8 x 3/4" SHEET METAL SCREWS	2
4FA018-021	8-GR 6.0/6.87 CRANK PULLEY	1	7R002-056	#56 HOSE CLAMPS	2
7A375-178	3/8-16 x 1-3/4" BOLTS	4	7U035-000	3-1/2" x 12" FLEX HOSE	1
7J375-044	3/8" SAE WASHERS	4	7R002-052	#52 HOSE CLAMPS	2
7L375-075	3/8" LOCK WASHERS	4	7P750-102	3/4"NPT x 1" 90° HOSE FITTING	1
2A048-545	BELT	1	<b>8F201-265</b>	<b>T-REX® PUMP ASSEMBLY</b>	<b>1</b>
<b>4FA238-068</b>	<b>FMU (WITH LINES)</b>	<b>1</b>	7F008-032	8-32 HEX LOCK NUTS	8
6Z110-111	12:1 BLACK FUEL MANAGEMENT UNIT	1	7J008-001	#8 FLAT WASHERS	8
4FA145-010	MALE FUEL ASSEMBLY	1	7P312-003	5/16" FEMALE FUEL CONNECTORS	2
4FA145-020	FEMALE FUEL LINE ASSEMBLY	1	7P312-001	FORD FUEL FITTING ADAPTER	1
7U030-046	5/32" x 54" VACUUM LINE	1	7R004-002	17.0 STEPLESS CLAMPS	2
7E010-046	#8 x 3/4" SHEET METAL SCREWS	2	7R004-001	15.7 STEPLESS CLAMPS	3
7U100-055	6" NYLON TIE-WRAP	2	7R001-004	#4 HOSE CLAMPS	2
<b>4FA130-026</b>	<b>OIL FEED ASSEMBLY</b>	<b>1</b>	7U314-001	#8 LORD MOUNTS	4
7P525-067	.500" CRIMP FERRULES	2	5W001-001	WIRE TAP	1
7P250-066	#4 SWIVEL x 1/4" HOSE BARB FITTINGS	2	7U032-016	3/8" x 6" FUEL HOSE	1
7P125-027	1/8" STRAIGHT FITTING	1	7E010-050	#12 x 1/2" SHEET METAL SCREW	1
7P125-103	1/8"NPT -4 x 45° MALE ELBOW	1	7U375-135	ADHESIVE MOUNTING PADS	4
7U030-026	1/4" x 25" OIL FEED HOSE	1	7U100-055	6" NYLON TIE-WRAP	6
7P250-121	3" NIPPLE	1	4FA020-030	T-REX PUMP TEMPLATE	1
7P250-122	1/4" TEE	1	8F101-200	T-REX WIRING ASSEMBLY	1
7P250-075	45° ELBOW	1	7U031-018	5/16" x 24" HP FUEL HOSE	1
7P250-082	90° FLARE	1	8F002-265	90° T-REX INLINE FUEL PUMP	1
			5W001-010	16-14GA FEMALE SLIDE	1
			5W001-002	FUSE TAP	1
			5W001-011	16-14GA EYELETS	2
			7U100-044	4" NYLON TIE-WRAP	4
			7U031-018	5/16" x 30" MPI HOSE	1





# 1986-1993 High-Output Mustang

Part No. 4FA218-040L/048L

## PARTS LIST

**IMPORTANT: Before beginning installation, verify that all parts are included in the kit. Report any shortages or damaged parts immediately.**

PART NUMBER	DESCRIPTION	QUANTITY	PART NUMBER	DESCRIPTION	QUANTITY
<b>2E328-010</b>	<b>V3-SI SUPERCHARGER ASSEMBLY</b>	<b>1</b>	<b>4FA139-096</b>	<b>PCV BYPASS KIT</b>	<b>1</b>
2E038-333	8-GR 3.33" SUPERCHARGER DRIVE PULLEY	1	8H040-020	3/8" INLINE FILTER	1
8R101-002	8 & 10-RIB PULLEY RETAINER ASSEMBLY	1	7U375-052	3/8" VACUUM CAP	1
			7U030-056	3/8" x 22" FUEL HOSE	1
<b>4FA111-021</b>	<b>MOUNTING BRACKET ASSEMBLY</b>	<b>1</b>	<b>4FA114-023</b>	<b>RADIATOR HOSE ASSEMBLY</b>	<b>1</b>
4FA011-021	MOUNTING BRACKET	1	4FA014-011	RADIATOR PIPE	1
4FA010-034	MOUNTING PLATE	1	7R002-024	#24 HOSE CLAMPS	2
4FA015-015	ALTERNATOR STAY	1			
4FA017-021	SMOG PUMP SPACER	1	<b>5A101-001</b>	<b>STAND ALONE ASSEMBLY</b>	<b>1</b>
7A375-625	3/8-16 x 6-1/4" BOLTS	2	7P156-082	5/32" TEE	1
7A375-700	3/8-16 x 7" BOLT	1	5A002-002	FORD EFI WIRING HARNESS	1
7A437-175	7/16-14 x 1-3/4" BOLT	1	5A001-001	STAND ALONE IGNITION RETARD	1
7A375-175	3/8-16 x 1-3/4" BOLT	1	7U030-046	5/32" x 24" VACUUM LINE	1
7A375-650	3/8-16 x 6-1/2" BOLT	1			
7A375-200	3/8-16 x 2" BOLT	1	<b>4FA112-030</b>	<b>DISCHARGE ASSEMBLY</b>	<b>1</b>
7A375-075	3/8-16 x 3/4" BOLT	1	4FA012-030	ALUMINUM DISCHARGE TUBE	1
7F375-016	3/8-16 NUTS	2	7S275-200	2-3/4" x 2" SLEEVE	1
7A375-100	3/8-16 x 1" BOLTS	7	7S300-200	3" x 2" SLEEVE	1
7K375-040	3/8" AN960 FLAT WASHERS	5	7R002-044	#44 HOSE CLAMPS	2
7J375-044	3/8" SAE WASHERS	10	7R002-048	#48 HOSE CLAMPS	2
7J012-092	12mm FLAT WASHER	1	8D001-001	BYPASS VALVE	1
			7P750-100	3/4"NPT x 1" STRAIGHT HOSE FITTING	1
<b>4FA110-011</b>	<b>SPRING TENSIONER MOUNTING ASSEMBLY</b>	<b>1</b>	7U134-145	1" x 4-1/2" HEATER HOSE	1
4FA010-011	TENSIONER MOUNTING BRACKET	1	7U134-130	1" x 3" HEATER HOSE	1
7A375-100	3/8-16 x 1" BOLTS	2	7R002-016	#16 HOSE CLAMPS	4
7J375-044	3/8" SAE WASHERS	2	7P156-082	5/32" TEE	1
7F375-016	3/8-16 NUT	1	7U030-046	5/32" x 24" VACUUM LINE	1
7A500-350	1/2-13 x 3-1/2" CARRIAGE BOLT	1			
7F500-013	1/2-13 HEX NUT	1	<b>4FA112-015</b>	<b>AIR INTAKE ASSEMBLY</b>	<b>1</b>
7J012-092	12mm FLAT WASHER	1	7S350-200	3-1/2" x 2" SLEEVE	1
			4FA012-013	90° INTAKE ELBOW	1
<b>4FA111-042</b>	<b>SUPERCHARGER BELT TENSIONER ASSEMBLY</b>	<b>1</b>	4FA013-010	AIR CLEANER COVER	1
7J012-092	12mm FLAT WASHERS	3	8H040-040	AIR FILTER	1
4FA011-032	BELT TENSIONER PLATE	1	7J006-093	6mm WASHERS	2
7C012-020	12mm x 1.75" x 20mm BOLTS	3	7P375-097	3/8"NPT x 3/8" BARB	1
7G010-175	12mm x 1.75" NUT	1	7S300-100	3" x 1" SLEEVE	1
4FA016-170	WIDE IDLER PULLEY	1	7E010-046	#8 x 3/4" SHEET METAL SCREWS	2
2A017-011	8-RIB IDLER SPACER	1	7R002-056	#56 HOSE CLAMPS	2
7C012-065	12mm x 1.75" x 65mm BOLT	1	7U035-000	3-1/2" x 12" FLEX HOSE	1
			7R002-052	#52 HOSE CLAMPS	2
<b>4FA116-041</b>	<b>CRANK PULLEY ASSEMBLY</b>	<b>1</b>	7P750-102	3/4"NPT x 1" 90° HOSE FITTING	1
4FA018-021	8-GR 6.0/6.87 CRANK PULLEY	1			
7A375-178	3/8-16 x 1-3/4" BOLTS	4	<b>8F201-265</b>	<b>T-REX® PUMP ASSEMBLY</b>	<b>1</b>
7J375-044	3/8" SAE WASHERS	4	7F008-032	8-32 HEX LOCK NUTS	8
7L375-075	3/8" LOCK WASHERS	4	7J008-001	#8 FLAT WASHERS	8
2A048-545	BELT	1	7P312-003	5/16" FEMALE FUEL CONNECTORS	2
			7P312-001	FORD FUEL FITTING ADAPTER	1
<b>4FA238-068</b>	<b>FMU (WITH LINES)</b>	<b>1</b>	7R004-002	17.0 STEPLESS CLAMPS	2
6Z110-111	12:1 BLACK FUEL MANAGEMENT UNIT	1	7R004-001	15.7 STEPLESS CLAMPS	3
4FA145-010	MALE FUEL ASSEMBLY	1	7R001-004	#4 HOSE CLAMPS	2
4FA145-020	FEMALE FUEL LINE ASSEMBLY	1	7U314-001	#8 LORD MOUNTS	4
7U030-046	5/32" x 54" VACUUM LINE	1	5W001-001	WIRE TAP	1
7E010-046	#8 x 3/4" SHEET METAL SCREWS	2	7U032-016	3/8" x 6" FUEL HOSE	1
7U100-055	6" NYLON TIE-WRAP	2	7E010-050	#12 x 1/2" SHEET METAL SCREW	1
			7U375-135	ADHESIVE MOUNTING PADS	4
			7U100-055	6" NYLON TIE-WRAP	6
			4FA020-030	T-REX PUMP TEMPLATE	1
			8F101-200	T-REX WIRING ASSEMBLY	1
			7U031-018	5/16" x 24" HP FUEL HOSE	1
			8F002-265	90° T-REX INLINE FUEL PUMP	1
			5W001-010	16-14GA FEMALE SLIDE	1
			5W001-002	FUSE TAP	1
			5W001-011	16-14GA EYELETS	2
			7U100-044	4" NYLON TIE-WRAP	4
			7U031-018	5/16" x 30" MPI HOSE	1
			009035	LUBE ASSY	1



# 1986-1993 Renegade Mustang

Part No. 4FA218-100

## PARTS LIST

**IMPORTANT: Before beginning installation, verify that all parts are included in the kit. Report any shortages or damaged parts immediately.**

PART NUMBER	DESCRIPTION	QUANTITY	PART NUMBER	DESCRIPTION	QUANTITY
<b>2A258-010</b>	<b>SUPERCHARGER ASSEMBLY</b>	<b>1</b>	<b>8E018-300</b>	<b>PULLEY PACKAGE, RENEGADE</b>	<b>1</b>
<b>4FA111-021</b>	<b>MOUNTING BRACKET ASSEMBLY</b>	<b>1</b>	2A038-300	SUPERCHARGER PULLEY 3" 8 GROOVE	1
4FA011-021	MOUNTING BRACKET	1	7A375-158	3/8-16 x 1.5" SOC HD	4
4FA010-034	MOUNTING PLATE	1	7K375-040	3/8" WASHER	4
4FA015-015	ALTERNATOR STAY	1	7L375-075	3/8" LOCK WASHER	4
4FA017-021	SMOG PUMP SPACER	1	4FA018-027	8" 8-GV CRANK PULLEY	1
7A375-625	3/8-16 x 6-1/4" BOLTS	2	8R101-002	PULLEY RETAINER ASSY, 8-RIB	1
7A375-700	3/8-16 x 7" BOLT	1	4FA1110042	S/C BELT TENSIONER ASSY, H.O.	1
7A437-175	7/16-14 x 1-3/4" BOLT	1	2A048-565	BELT	1
7A375-175	3/8-16 x 1-3/4" BOLT	1	<b>4FA212-050</b>	<b>V-7 DISCHARGE WITH BYPASS</b>	<b>1</b>
7A375-650	3/8-16 " 6-1/2" BOLT	1	7S003-200	3" x 2" SLEEVE	1
7A375-200	3/8-16 x 2" BOLT	1	7S300-275	REDUCER, 3.00" - 2.75"	1
7A375-075	3/8-16 x 3/4" BOLT	1	7R002-052	#52 HOSE CLAMP	2
7F375-016	3/8-16 NUTS	2	7R002-048	#48 HOSE CLAMP	2
7A375-100	3/8-16 x 1" BOLTS	7	8D103-001	MAXFLOW MONDO BYPASS VALVE	1
7K375-040	3/8"AN960 FLAT WASHERS	5	4FA012-041	DISCHARGE TUBE, RACE	1
7J375-044	3/8"SAE WASHERS	10	7S325-200	3.25" x 2" SLEEVE	1
7J012-092	12mm FLAT WASHER	1			
<b>4FA110-011</b>	<b>SPRING TENSIONER MOUNTING ASSEMBLY</b>	<b>1</b>			
4FA010-011	TENSIONER MOUNTING BRACKET	1			
7A375-100	3/8-16 x 1" BOLTS	2			
7J375-044	3/8"SAE WASHERS	2			
7F375-016	3/8-16 NUT	1			
7A500-350	1/2-13 x 3-1/2" CARRIAGE BOLT	1			
7F500-013	1/2-13 HEX NUT	1			
7J012-092	12mm FLAT WASHER	1			
<b>4FA130-026</b>	<b>OIL FEED ASSEMBLY</b>	<b>1</b>			
7P525-067	.500" CRIMP FERRULES	2			
7P250-066	#4 SWIVEL x 1/4" HOSE BARB FITTINGS	2			
7P125-027	1/8" STRAIGHT FITTING	1			
7P125-103	1/8"NPT -4 x 45° MALE ELBOW	1			
7U030-026	1/4" x 25" OIL FEED HOSE	1			
7P250-121	3" NIPPLE	1			
7P250-122	1/4" TEE	1			
7P250-075	45° ELBOW	1			
7P250-082	90° FLARE	1			
<b>4FA130-036</b>	<b>OIL DRAIN ASSEMBLY</b>	<b>1</b>			
7R001-008	#8 STAINLESS HOSE CLAMPS	2			
7P375-017	3/8"NPT x 1/2" STRAIGHT HOSE BARB	2			
7U030-036	1/2" x 28" OIL DRAIN HOSE	1			
<b>4FA112-070</b>	<b>AIR INLET ASSEMBLY</b>	<b>1</b>			
4FA112-060	4" INLET DUCT WITH BUNG	1			
7S400-200	4" x 2" SLEEVE	2			
7R002-064	#64 HOSE CLAMP	4			
7S00-325	2" x 3.25" SLEEVE	1			
7R002-032	#32 HOSE CLAMP	2			
<b>4FA114-023</b>	<b>RADIATOR HOSE ASSEMBLY</b>	<b>1</b>			
4FA014-011	RADIATOR PIPE	1			
7R002-024	#24 HOSE CLAMPS	2			



# 1986-1993 5.0 S.H.O. V-7 Mustang

## Part No. 4FA218-200

# PARTS LIST

**IMPORTANT: Before beginning installation, verify that all parts are included in the kit. Report any shortages or damaged parts immediately.**

PART NUMBER	DESCRIPTION	QUANTITY	PART NUMBER	DESCRIPTION	QUANTITY
<b>2A258-020</b>	<b>SUPERCHARGER, YSI, 3.33" 10-RIB</b>	<b>1</b>	<b>4FA112-090DISCH. ASSY S.H.O. V-7 KIT-SATIN</b>	<b>1</b>	<b>1</b>
<b>4FA111-031</b>	<b>MNTG BRCKT ASSY, S.H.O.</b>	<b>1</b>	4FA012-041	DISCHARGE TUBE, RACE	1
4FA010-045	ALUM. MTG PLATE, BILLET 5.0	1	7S300-200	3" x 2" SLEEVE	1
4FA011-021	MOUNTING BRACKET	1	7S325-200	3.25" x 2" SLEEVE	1
4FA015-015	ALTERNATOR STAY-PLATED	1	7R002-052	#52 GOLDSEAL HOSE CLAMP	2
4FA017-021	SPACER, SMOG PUMP	1	7R002-048	#48 GOLDSEAL HOSE CLAMP	2
7A375-075	3/8-16 x 3/4" GR5 HXHD	1	8D204-001	MAXFLOW RACE BYPASS	1
7A375-100	3/8-16 x G5 HXHD PLT	8	7P250-030	1/4" BARBED MALE TEE	1
7A375-175	3/8-16 x 1-3/4 HXHD	1	7U030-030	1/4" VACUUM HOSE	2'
7A375-200	3/8-16 x 2 GR5 PLTD	1	<b>4FA112-080 4" AIR INLET ASSY, 5.0 S.H.O.</b>	<b>1</b>	<b>1</b>
7A375-625	3/8-16 x 6-1/4 HXHD	2	4FA112-080	4" ELBOW, W/BUNG	1
7A375-675	3/8-16 x 6.75" HXHD GR8 ZINC	1	7S400-200	4" x 2" SLEEVE	1
7A375-751	3/8-16 x 7.5" HXHD GR8 ZINC	1	7R002-064	#64 GOLDSEAL HOSE CLAMP	2
7A437-175	7/16-14 x 1-3/4" HXHD	1	7S175-400	Ø1.75" x 4" SLEEVE	1
7F375-016	3/8-16 HX NUT	2	7R002-028	#28 GOLDSEAL HOSE CLAMP	2
7J012-092	12mm WASHER, FLAT	1	7U030-056	3/8" PCV HOSE x 1.5"	1
7J375-044	3/8"SAE WASHER, PLTD	6	7P250-047	1/4"NPT TO 3/8" BARB 90°	1
7K375-040	3/8"AN960 FLAT WASHER	12	<b>8F201-265 T-REX PMP ASSY, 86-93 5.0</b>	<b>1</b>	<b>1</b>
<b>4FA116-150 CRK PLY ASSY, 10RIB V-7 KIT</b>	<b>1</b>	<b>1</b>	5W001-001	WIRE TAP	1
7B375-150	3/8-24 x 1-1/2" GR8 HX	1	5W001-002	FUSE TAP	1
7A375-178	3/8-16 x 1-3/4" HXHD G8	4	5W001-040	12-10GA FEMALE SLIDE	1
7J375-044	3/8"SAE WASHER, PLTD	4	5W001-042	12-10GA 3/16" RING TERMINAL	2
7L375-075	3/8 LOCK WASHER	4	4FA020-030	TEMPLATE, T-REX PUMP	0
2A041-545	BELT, CUSTOM 545, 10-RIB SERP	4	7E010-050	#12 x 1/2" SHEET METAL SCREW	1
4FA018-023	4.75/6.87 10-GR CKPLY	1	7F008-032	8-32 HEX LOCK NUT	8
4FA017-051	FAN SPACER 5.0"	1	7J008-001	#8 FLAT WASHER	8
7U313-021	5/16-24 x 1.5" STUD	4	7P312-001	ADAPTER, FUEL FITTING	1
7F312-021	5/16-24 NUT	4	7P312-003	5/16" FEMALE FUEL	2
7J312-000	5/16" FLAT WASHER-SAE	4	7R001-004	#4 HOSE CLAMP	2
<b>4FA238-068 FMU 12:1 W/LINES</b>	<b>1</b>	<b>1</b>	7R004-003	14.5 STEPLESS CLAMP	3
6Z110-111	FUEL MGMT UNIT, 12:1	1	7R004-002	17.0 STEPLESS CLAMP	2
4FA145-010	FUEL LINE 5.0-MALE	1	7U100-044	TIE-WRAP, 4" NYLON	4
4FA145-020	FUEL LINE 5.0-FEMALE	1	7U100-055	TIE-WRAP, 6" NYLON	6
7U030-046	5/32" VACUUM LINE	4.5	7U031-018	5/16" FUEL HOSE HI-PSR x 2"	1
7U100-055	TIE-WRAP, 6" NYLON	2	7U031-018	5/16" FUEL HOSE HI-PSR x 2.5"	2.1
<b>4FA130-027 OIL FEED ASSEMBLY</b>	<b>1</b>	<b>1</b>	7U032-016	3/8" FUEL HOSE HI-PSR x 6"	.1
7P125-027	FITTING, STRGT, 1/8"NPT	1	7U314-001	#8 LORD MOUNTS	4
7P125-103	-4 x 45° FITTING	1	7U375-135	ADHES MTNG PAD	4
70000	INSPECTOR NUMBER	0	8F002-265	T-REX FUEL PUMP-INLINE 90°	1
7P250-121	1/4"NPT STEEL NIPPLE	1	8F101-200	T-REX WIRING ASSY MUSTANG	1
7P250-122	1/4" PIPE THRD AN917 TEE	1	5W001-014	FUSE HOLDER 10GA WIRE	1
7P250-075	1/4"NPT 45° STRT ELBOW	1	5W001-015	FUSE, BLADE TYPE 20AMP	1
7P250-082	1/4"NPT x -4 90° FITTING	1	5W001-019	SOLDERLESS CONNECTOR 10-12	1
4FA145-030	OIL FEED HOSE ASSY 5.0 86-93	1	<b>8F110-011 SPRING TENS. MOUNT</b>	<b>1</b>	<b>1</b>
<b>4FA130-036 OIL DRAIN ASSEMBLY</b>	<b>1</b>	<b>1</b>	4FA010-011	TENS. BRKT.-MACH	1
7U030-036	1/2" OIL DRAIN HOSE x 28"	1	7A375-100	3/8-16 x 1" G5 HXHD PLT	2
7P375-017	3/8"NPT x 1/2" HOSE BARB	1	7A500-350	1/2-13 x 3-1/2" CARRIAGE	1
7R001-008	#8 STNLS HOSE CLAMP	2	7F375-016	3/8-16 HEX NUT	1
<b>4FA114-011 RADIATOR HOSE ASSEMBLY</b>	<b>1</b>	<b>1</b>	7F500-013	1/2-13 HEX NUT	1
4FA014-011	RADIATOR PIPE-POLISHED	1	7J012--92	12mm WASHER, FLAT	1
7R002-024	#24 GOLDSEAL HOSE CLAMP	2	7J375-044	3/8"SAE WASHER, PLTD	3



# 1986-1993 5.0 S.H.O. V-7 Mustang, cont'd.

Part No. 4FA218-200

## PARTS LIST

**IMPORTANT: Before beginning installation, verify that all parts are included in the kit. Report any shortages or damaged parts immediately.**

PART NUMBER	DESCRIPTION	QUANTITY
<b>4FA111-062</b>	<b>S/C BELT TENSNR ASSY, S.H.O.</b>	<b>1</b>
4FA011-042	BELT TENSIONER PLATE	1
2A017-012	SPACER, 10-RIB IDLER	1
7C012-065	12mm x 1.75" x 20mm PLD	3
7C012-065	12mm x 1.75" x 65mm HX	1
7G010-175	12mm x 1.75" NUT	1
7J012-092	12mm WASHER, FLAT	3
4FA016-171	DUST COVER (WIDE IDLER)	1
4FA016-170	IDLER PULLEY, WIDE	1
<b>8H140-000</b>	<b>FENDER MOUNT MAF KIT 86-93</b>	<b>1</b>
8H040-030	AIR FILTER 3-1/2" CYL	1
7S350-300	3-1/2" x 3" SLEEVE	1
7S350-200	3-1/2" x 2" SLEEVE	1
4FA012-012	INTAKE ELBOW, 90°	2
7R002-056	#56 GOLDSEAL HOSE CLP	4
7C060-016	M6 x 1.00" x 16 HXHD	3
7J006-093	6mm WASHER, PLATED	3
5W001-007	3/16" HEAT-SHRINK TUBE	.666'
5W018-020	18GA STRD WIRE BLK	1'
5W018-010	18GA STRD WIRE RED	1'
5W018-060	18GA STRD WIRE ORANGE	1'
5W018-070	18GA STRD WIRE GREEN	1'
4FA020-020	TEMPLATE, MASS AIR	0
7U035-001	3-1/2" FLEX HOSE	1
<b>2A046-888</b>	<b>BELT, K060888</b>	<b>1</b>

SPECIAL NOTICE CONCERNING THE  
**MSD IGNITION SYSTEM**

The MSD Boost Timing Master, manufactured by Autotronic Controls Corporation, that may be included in this kit, is serviced exclusively by the manufacturer. Autotronic Controls Corporation warrants this product to be free from defects in material and workmanship under normal use and if properly installed for a period of one (1) year from the date of purchase. In case of malfunction, this unit will be repaired free of charge according to the terms of the warranty. If found to be defective as mentioned above, it will be repaired or replaced if returned prepaid along with proof of purchase. This shall constitute the sole remedy of the purchaser and the sole liability of Autotronic Controls Corporation and/or Vortech Engineering, Inc. To the extent permitted by law, the foregoing is exclusive and in lieu of all other warranties or representations whether expressed or implied, including any implied warranty of merchantability or fitness. In no event shall Autotronic Controls Corporation and/or Vortech Engineering, Inc. be liable for labor charges, special or consequential damages.

When returning this unit for service, proof of purchase must be supplied for warranty verification. After the warranty period has expired, repair service is charged between a minimum and maximum charge. In either case, please send the unit pre-paid with proof of purchase to the attention of:

**Autotronic Controls Corporation  
Customer Service Department  
12120 Esther Lama  
Suite #114  
El Paso, Texas, 79936  
Phone: (915) 855-7123  
Fax: (915) 857-3344  
www.msdition.com**

The repaired unit will be returned as soon as possible after receipt, COD for any charges. Be sure you include a detailed account of any problems experienced, the type of vehicle and any modifications.

Should you have any technical or installation questions regarding this unit, contact Vortech Engineering, Inc. directly at (805) 247-0226.

## 1. PREPARATION/REMOVAL

- A. Disconnect the battery negative cable.
- B. Remove the accessory drive belt. Super High-Output (S.H.O.) V-7 installations also require removal of the shroud and fan from the vehicle.
- C. Remove the radiator fan assembly and carefully place it in the fan shroud, out of the way.
- D. Remove all components that lead to the throttle body including air filter assembly, rubber bellows, mass air flow (MAF) sensor and bracket with rubber mounts and resonator from inner fender. Separate the MAF sensor from the mounting bracket and set aside.
- E. The ground wire attached to the radiator support must be rerouted so as to pass through the hole behind the right headlight and secured from the front. Make sure to clean away any paint that would insulate the end of the ground wire from the grounding point on the vehicle.
- F. Drain approximately one gallon of coolant. Remove upper radiator hose and set aside.
- G. Remove the crankcase vent tube from between oil filter and throttle body.
- H. Remove belt tensioner assembly.
- I. Unplug wire connections and remove alternator assembly (make sure the battery is disconnected).
- J. Remove brace from between the smog pump and front engine cover.
- K. Disconnect hoses and remove smog pump and cast mounting bracket.
- L. Relocate the evaporative canister forward (at a slight angle) by using only the front bolt in the bracket rear hole. (See Fig. 1-a.)

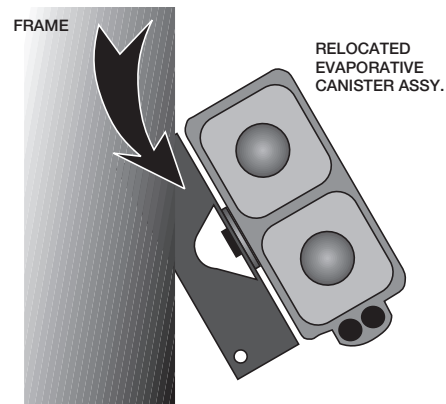

Fig. 1-a

## 2. CRANKSHAFT PULLEY

- A. Remove crankshaft pulley.
- B. For the standard output system, place the cast Vortech crank pulley into the stock pulley as shown and secure with the longer bolts and washers as a unit.
- C. For the Vortech High Output, S.H.O. or V-7 Renegade system, remove the factory crank pulley and replace with the new high output crank pulley; secure with the supplied bolts and washers.

**NOTE:** Tighten bolts progressively and evenly in a crisscross pattern so that pulleys align properly.

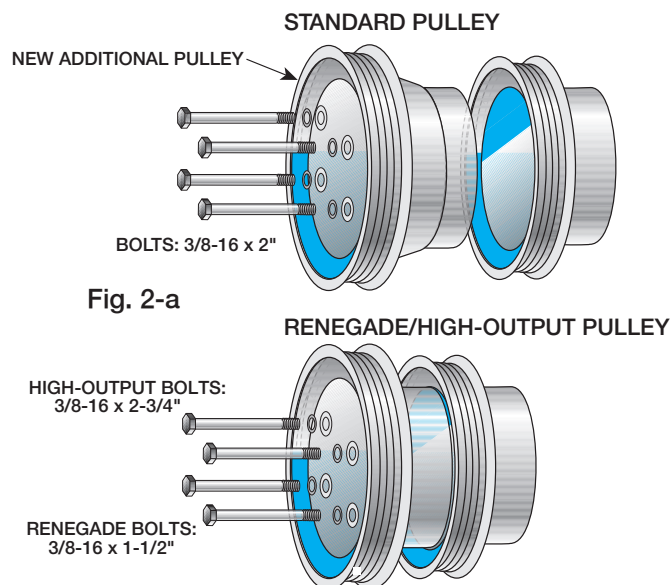

Fig. 2-a

Fig. 2-b



### 3. OIL DRAIN (Engine oil fed kits only. V3 kits, skip ahead to section 5)

- To provide an oil drain for the supercharger, it is necessary to make a hole in the oil pan. Locate and mark hole per diagram. It is best to punch the hole rather than drill.
- Remove paint around the hole area.
- Use a small center punch to perforate the pan and expand hole. Switch to a larger diameter punch and expand the hole further to approximately 9/16" diameter. Most punches are made from hexagon material and may be placed in a socket with an extension to make this procedure easier.
- Tap the hole with a 3/8" NPT tap approximately 1/4" deep. Pack the flutes of the tap with heavy grease to hold chips. Use a small magnet to check for any stray chips.

**NOTE:** This method of rolling over the lip of the hole and tapping it works very well if carefully done and should cause no problems.

- Thoroughly clean the threaded area. Apply a small amount of silicone sealer to the new threads. Apply more sealer to the 3/8" NPT hose fitting and secure in hole. Make sure a seal is formed all around the fitting.
- Drain the engine oil and change the filter.

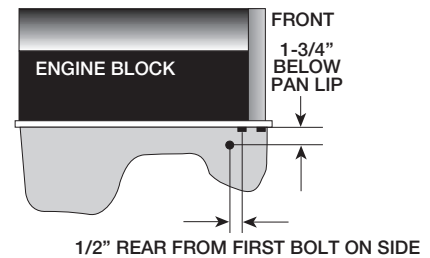

Fig. 3-a

### 4. OIL FEED LINE (Engine oil fed kits only. V3 kits, skip ahead to section 5)

- Remove the oil pressure sender and mounting boss fitting from the engine. These are found on the engine's left side just ahead of the oil filter.
- Thread the supplied 3" x 1/4" NPT nipple into the block using engine oil on the threads. Pipe tape, paste or other sealant is not recommended as it might loosen and cause blockage of the oil feed orifice, resulting in supercharger failure.
- Thread the supplied 1/4" female TEE into the nipple. Rotate the TEE so that the center leg points toward the front of the vehicle. Thread the 45° elbow into the leg of the TEE pointing toward the side of the vehicle.
- Install the factory sending unit into the 45° elbow.
- Thread the supplied flare fitting into the remaining leg of the TEE.
- Connect the red oil feed line to the fitting at the pressure sender and route it behind the A/C mounting plate to the supercharger location. Cover the end of the hose with a clean plastic bag. Connect the line to the supercharger with the flare fitting provided.

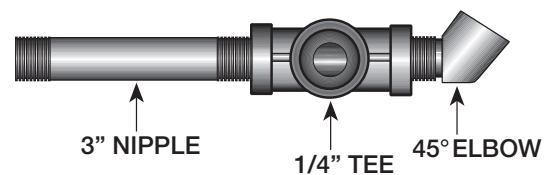

Fig. 4-a

## 5. FUEL MANAGEMENT UNIT (skip this step for Renegade applications)

- A. Relocate the relay using the stock screw.
- B. Locate the fuel management unit against the inner fender panel ahead of the shock tower about an inch from the top. Drill holes and secure with the sheet metal screws provided. (See Fig. 5-a.)
- C. Disconnect the fuel rail return line at the rubber hose on the engine's lower right side with a 3/8" spring lock disconnect tool. The return line does not have the pressure test fitting on it.

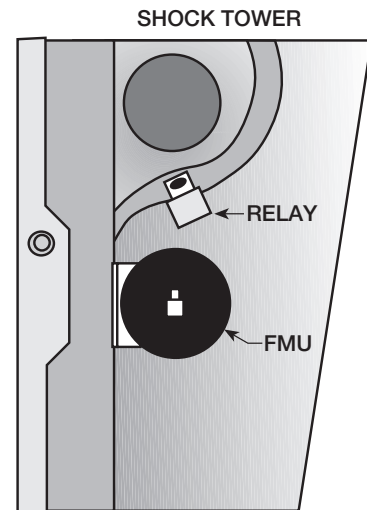
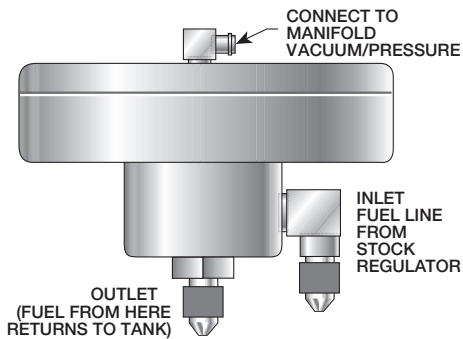

Fig. 5-a

- D. Connect the Fuel Management Unit (FMU) input hose (the hose that goes to the 90° fitting on the side of the FMU) to the return line coming from the fuel rail regulator as shown in Fig. 5-b.
- E. Connect the unit's return hose (that connects to the center fitting) to the stock return hose.
- F. Secure the fuel lines away from the exhaust header with the tie wraps provided.
- G. Connect the top fitting on the FMU to the multi-branch fitting located on the driver's side firewall using the supplied 5/32" hose. Use the port with the "B/R" designation. (See Fig. 5-c.)

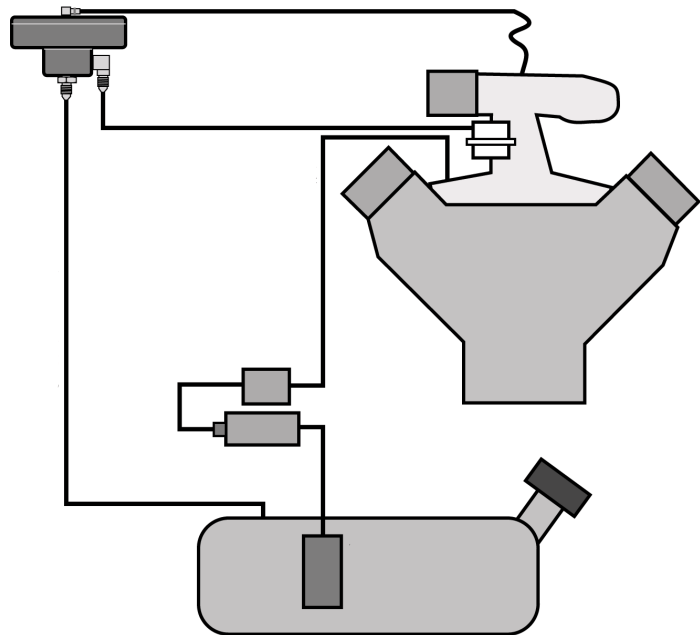

Fig. 5-b

**NOTE:** Add on inline fuel pump with unit provided if installing high output system.

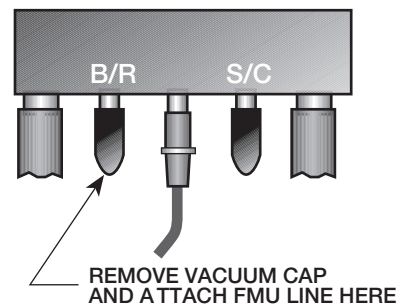

Fig. 5-c

## 6. T-REX® FUEL PUMP (H.O., S.H.O. and Cobra Systems Only)

**NOTE:** Make sure that the fuel level is below 1/4 tank for easier installation.

- A. Remove spare tire, etc. from trunk.
- B. Trim "cut-out" from template and place over spare tire hold-down. Centerpunch and drill holes 3/16" diameter.
- C. Jack up the rear of the car and support with jack stands.
- D. Drop down the fuel tank by loosening the filler neck and the two tank mounting straps. (There is no need to disconnect any of the wiring or to completely remove the tank.)
- E. Disconnect and remove the original rubber fuel line running from the tank to the fuel filter. Remove the 90° plastic fitting from the feed hose and set aside.
- F. Attach one end of the supplied fuel line with connections to the fuel tank pickup (see below). Route the hose around to the front of the tank in the factory manner.
- G. Place the Vortech supplied fuel adapter fitting, located in the T-Rex pump inlet hose, into the new feed line coming from the tank. Make sure that the white plastic retainer clip is in place.
- H. Reinstall the fuel tank and filler tube. Take care to route the fuel lines and vent lines away from exhaust pipes and provide room so that lines are not crushed between the floor pan and the tank.

### T-REX FUEL PUMP ASSEMBLY

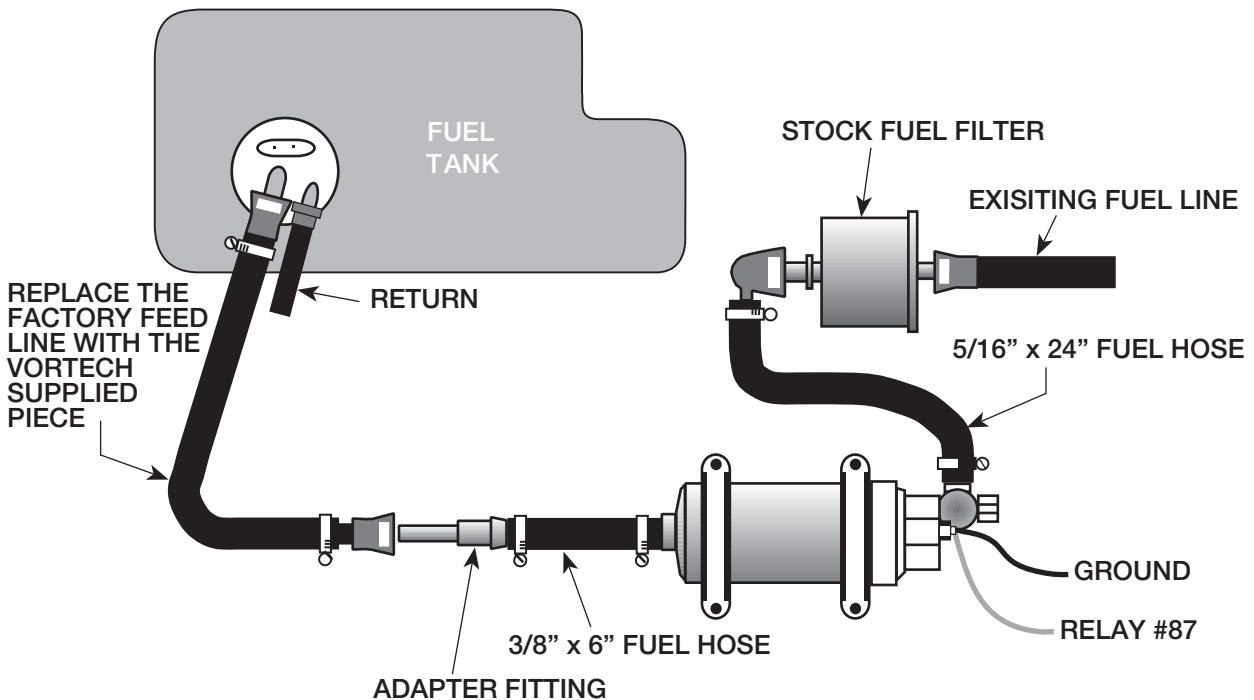

Fig. 6-a

## **6. T-REX® FUEL PUMP (H.O., S.H.O. and Cobra Systems Only) cont'd.**

- I. Mount pump to the underside of the tire well with rubber mounts, adel clamps and fasteners.
- J. Connect the hoses to pump inlet and outlet. This operation is completed at the Vortech factory for most models.
- K. Place the 90° fuel connector (removed from stock line) into the end of the 5/16" outlet hose from the pump.
- L. Connect the 90° end to the inlet side of the fuel filter. Use cable ties to keep lines up against underbody.
- M. Mark and drill a 1/8" hole and mount relay inside trunk in position as shown in template.
- N. From relay terminal #85, tap the yellow wire into the stock fuel harness in trunk near the right tail light. Tie into red/purple wire with a scotch lock. (On some model years, wire may be brownish-green.)
- O. Connect the short red wire to the (+) terminal at the fuel pump relay terminal #87.
- P. Connect the longer black wire from the (-) terminal at the fuel pump to a clean ground.
- Q. Connect the short black wire to the ground from relay terminal #86 (relay screw mount works well).
- R. Connect the long red wire from relay terminal #30 to the fuse box with supplied fuse tap and inline fuse. (The fused side of the cigarette lighter is the preferred location.)
- S. Check over the job and make sure everything is secure and away from all moving parts and exhaust pipes. Make sure no wires will rub on sharp edges. After you have activated the pump, check for any leaks and correct if necessary.

**SCHEMATIC (H.O., S.H.O. and Cobra systems only)  
VORTECH T-REX WIRING AND PLACEMENT GUIDE**

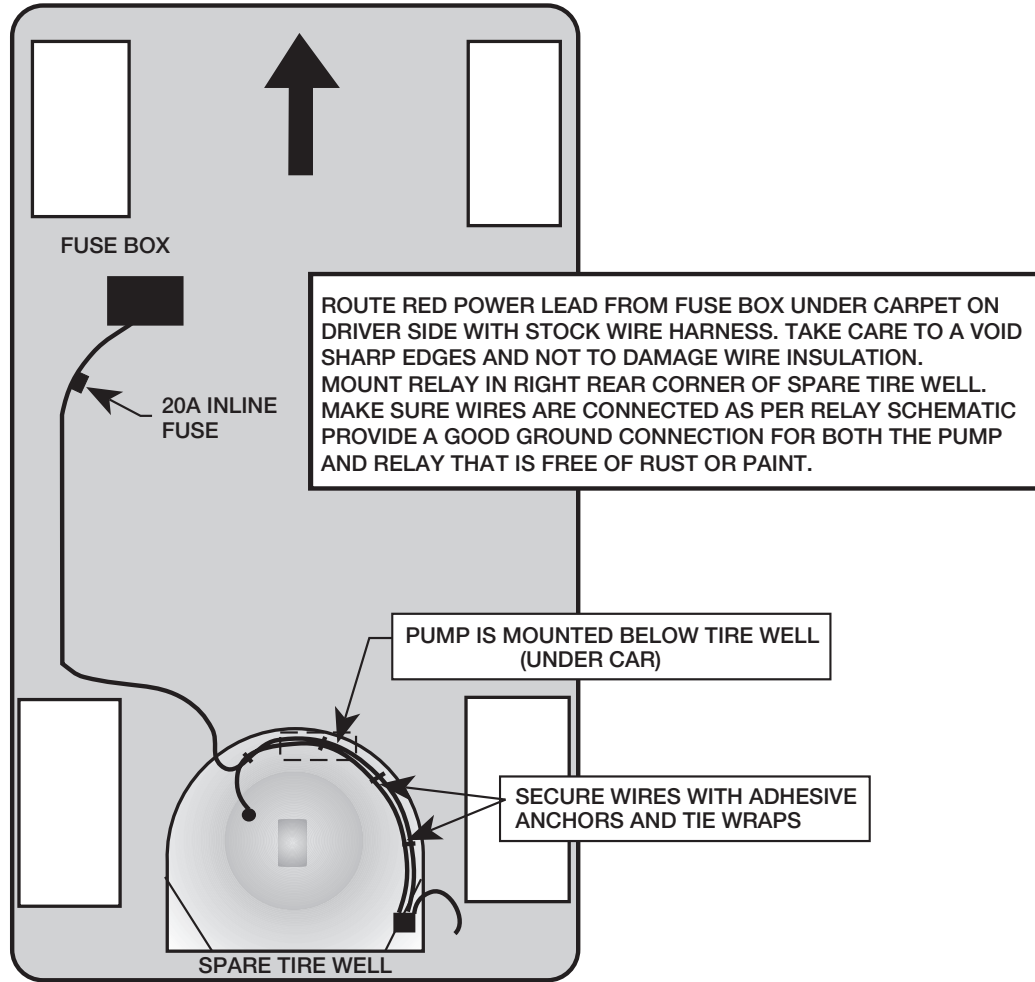

Fig. 6-a

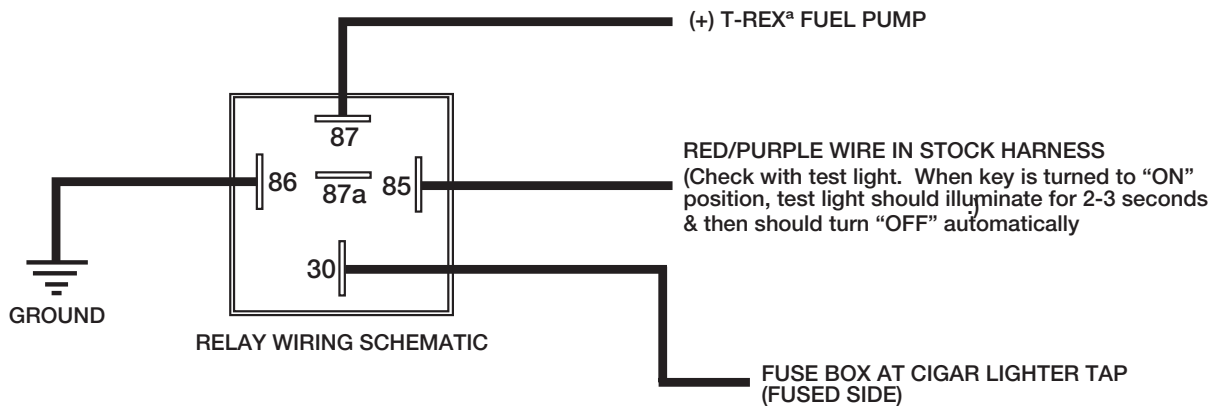

Fig. 6-b

## 7. MAIN BRACKET ASSEMBLY

Assemble the main bracket, plate and other parts necessary to relocate the alternator and smog pump and make room for the supercharger. For 1992 and later vehicles, please review points A through H before starting.

- A. Measure the length of the pivot boss on the alternator and record. It should be very close to 3".
- B. In a similar manner, measure the boss on the smog pump. When combined with the .920" spacer, it should be 4.050". Record these measurements so that in the event of a belt alignment problem, Vortech can properly advise you.

### 1986-93 S.H.O./RENEGADE V-7 KITS ONLY

**NOTE:** The upper mounting bolt boss on the smog pump (if equipped) requires grinding to allow for fitment of the V-7 compressor (see Fig. 7-b).

- C. Place the smog pump and alternator on the large aluminum mounting bracket as shown. After making sure the 6 1/4" bolts have a washer on them, enter the cast mounting bracket from the rear (coming towards you). Place the .920" tube spacer over the bolt on the smog pump. Lower supercharger mounting plate over bolts. The idea is to sandwich the alternator and smog pump between the mounting bracket and plate. Place washers and nuts on the 6-1/4" bolts and finger tighten. For vehicles equipped with alternators having larger 7/16" pivot bolts, it will be necessary to enlarge the corresponding hole in the plate.
- D. Start the 3/8-16 x 1" fastener with a washer at the top of the bracket and finger tighten. Insert the 6-1/2" and 7" bolts. These bolts will later hold assembly to engine.

**NOTE:** Remember to place the .920" spacer between the smog pump and mounting plate.

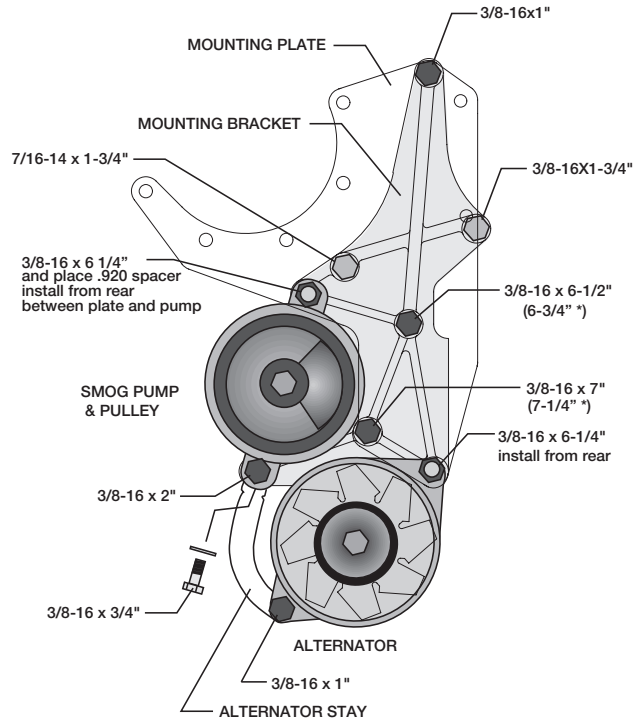

Fig. 7-a

\* V-7 application with aluminum mounting plate requires 6-3/4" and 7-1/4" bolts.



### S.H.O./RENEGADE V-7 KIT ONLY

Fig. 7-b



## 7. MAIN BRACKET ASSEMBLY (cont'd.)

- E. Attach the Vortech alternator brace between the boss on the smog pump and alternator with the 3/8-16 x 1" bolts. On 1992 and later Mustangs, it may be necessary to drill and tap the "blanked" hole in the smog pump. To accomplish this use an R size bit and a 3/8-16 size tap.
- F. Tighten all fasteners in the bracket/ accessory assembly.
- G. Lower the entire assembly into position and start all four fasteners that hold it to the engine. Tighten all fasteners in a progressive manner.
- H. Reconnect alternator wires and use a tie wrap to secure the wires.

## 8. SMOG PUMP HOSES

### 1986-93 RENEGADE 5.0L KIT ONLY

**NOTE:** Due to the location of the Vortech Mondo bypass valve, removal of the air injection hose assemblies is required for proper bypass valve installation. This modification is for off-road use only. Disregard the following steps A thru E.

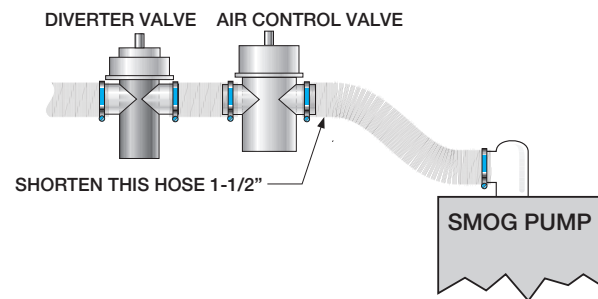

Fig. 8-a

- A. Separate the short hose and bent hose from the air control valve and place the shorter hose on the diverter valve (the valve closest to the firewall) as shown.
- B. Connect the air control valve to the short hose.
- C. Trim approximately 1-1/2", or as necessary, off the longer straight portion of the bent hose for proper fit.
- D. Secure the hose as shown with the stock clamps.
- E. It may be necessary to reroute the vacuum control line after the supercharger is in place.

## 9. RADIATOR HOSE

- A. From the stock radiator hose, make two 90° elbows by trimming as shown. The first is with 3" long legs for the thermostat housing end. The second, with 2" long legs, is from the middle of the stock hose and attaches to the radiator.

**NOTE:** S.H.O. V-7 APPLICATIONS - The 10-rib supercharger pulley supplied in this kit fits close to the upper radiator hose. More trimming than shown in Fig. 9-a may be required.

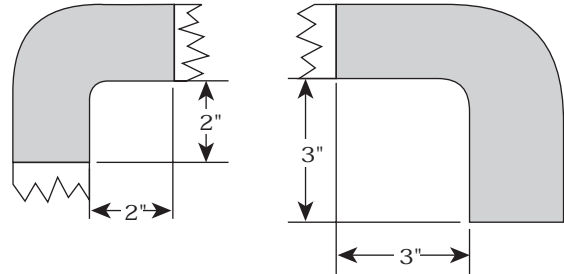

Fig. 9-a

- B. Place the stainless water pipe between the two hoses placing the shorter leg nearer the radiator.
- C. Position the hoses and tube so there is ample overlap for sealing and secure with provided clamps.
- D. Refill radiator and coolant bottle.

**NOTE:** Make sure the cooling system is completely full. Air is often trapped in 5.0 systems.

## 10. ACCESSORY BELT TENSIONER MOUNTING BRACKET

- A. Secure the factory spring tensioner assembly to the Vortech belt tensioner mounting bracket using the 1/2" carriage bolt.
- B. Replace the locking type nut on the A/C mounting bracket stud closest to the water pump with a standard nut.
- C. Depending on Ford's manufacturing tolerances, it may be necessary to trim about 1/8" off the edge of the flange on the A/C mounting bracket to provide room for the tensioner mounting bracket.
- D. Install the tensioner mounting bracket with tensioner between the supercharger mounting plate and A/C bracket stud using two standard flat washers as a spacer. Secure with two 3/8-16 x 1" bolts and washers and a 3/8-16 nut.
- E. Reinstall radiator shroud and fan assembly. (Slight shroud trimming may be required on S.H.O. applications.)

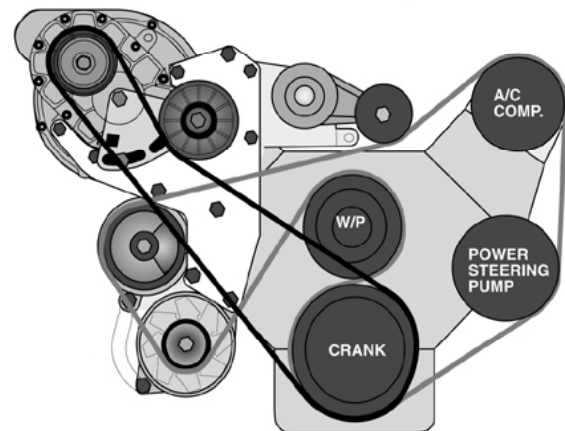

Fig. 10-a

**NOTE:** On S.H.O. applications, a fan spacer, studs and nuts have been supplied. Install these items before installing the fan

**NOTE:** Check the accessory belt tensioner pulley alignment. It may be necessary to add or remove a washer to the stud behind the tensioner bracket.

- F. Reinstall stock accessory belt. (On S.H.O. applications, use the supplied 888 belt for the accessory drive.)

## 11. SUPERCHARGER MOUNTING

- \*A. Place the oil drain hose onto the supercharger drain fitting and secure with a hose clamp. Arrange the clamp screw housing so it will not interfere with the mounting plate when installed.
- \*B. Feed the oil drain hose over the top of the smog pump and down towards the oil pan fitting while lowering the supercharger into position.
- C. Secure the supercharger with five 3/8-16 x 1" bolts and AN washers.
- \*D. Connect the lower end of the oil drain hose to the fitting on the pan and secure with a hose clamp.
- \*\*E. Secure the remote drain hose away from the belt and other hoses using tie-wraps.

\* Engine oil fed kits only  
\*\* V3 kits only

## 12. SUPERCHARGER DRIVE BELT

### 1986-93 RENEGADE 5.0L KIT ONLY

NOTE: The factory water pump pulley must be removed and replaced with an aftermarket unit for proper supercharger drive belt clearance. Also, an aftermarket electric fan is recommended, although the factory mechanical fan may still be retained with minor clearance modifications.

- A. Place the supercharger belt idler assembly on the supercharger using the 12mm bolts and washers. Position the thin head bolt nearest pulley.
- B. Fit the supercharger drive belt over the new crank pulley and supercharger pulley.
- C. Tension the belt by rotating the tensioner plate and secure.

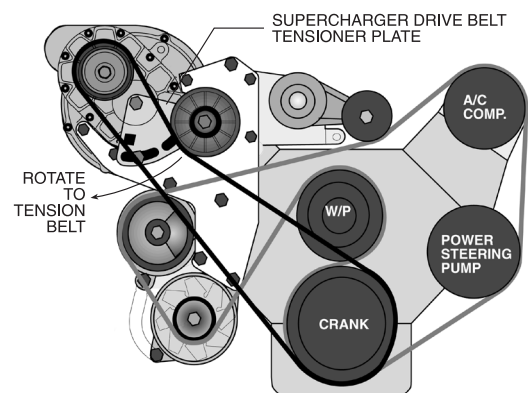

Fig. 12-a

## 13. AIR FILTER ASSEMBLY (skip to step I for Renegade applications and step J for S.H.O. applications)

- A. Place the Vortech air filter cover against the inner fender just behind the right headlight. Use it as a template to mark and drill two 3/32" holes. Do not install the cover at this time.
- B. Insert the mass air flow (MAF) sensor into the back of the air filter cover. Place the air filter with clamp, from the inside, over the protruding MAF and the air filter flange. Rotate the MAF so that the connector runs parallel to the top as shown. Tighten the clamp.
- C. Mount the air filter assembly behind the headlight and secure with sheet metal screws provided.
- D. Attach the 3" molded elbow to the supercharger with the sleeve and clamps.
- E. Connect the 3" flex tube to the molded elbow and the back of the MAF with the 3" x 1" adapter sleeve on the MAF (as a spacer) and secure with clamps.
- F. Connect the air discharge tube to the throttle body and supercharger with the sleeves and clamps provided.

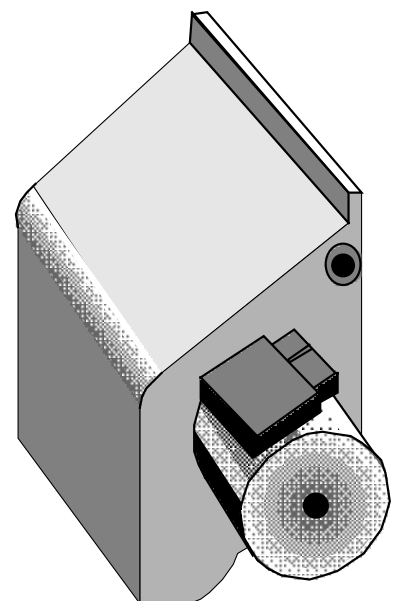

Fig. 13-a

### 13. AIR FILTER ASSEMBLY (skip to step I for Renegade applications) cont'd.

**NOTE:** If kit is a High Output or Cobra model refer to step 16, and Step J for S.H.O. applications.

- G. Clamp the provided rubber cap onto the vent fitting on the throttle body.
- H. With the 3/8" rubber hose, route blowby to the air filter cover through the inline filter provided.
- I. 1986-93 RENEGADE 5.0L KIT ONLY:

Install the supplied 4" aluminum elbow onto the supercharger inlet using the silicone sleeve and #64 clamps. The inlet elbow is supplied with cast-in bosses that can be drilled and threaded for a valve cover breather fitting (Note: The engine valve cover vent **MUST** be properly baffled or else the supercharger may pull in oil from the engine). The aluminum elbow can then be attached to the vehicles' MAF and air inlet filter. Vehicles equipped with an Anderson Power Pipe can be easily adapted to the Vortech inlet elbow by using the supplied 4" silicone sleeve and #64 clamps.

- J. S.H.O. V-7 KITS ONLY: INNER FENDER AIR INLET KIT
  1. Thread the supplied 3/8 x 90" x 1/4 NPT fitting into the 4" aluminum inlet elbow.
  2. Install the elbow onto the supercharger inlet using the supplied silicone sleeve and #64 clamps.
  3. Route the supplied 3/8" blowby hose from the valve cover to the supercharger inlet elbow fitting and trim if necessary. (Note: The engine valve cover vent **MUST** be properly baffled or else the supercharger may pull in oil from the engine).
  4. Cut out the Vortech provided template. Using the template, mark and drill the hole pattern into the fender apron.
  5. Remove the round plastic cover at the rear of the oval opening on the inner fender.
  6. Remove the plastic fender lining from the right fender.
  7. Attach the filter to the mass air flow (MAF) sensor and secure with the clamp. Place the MAF in the fender from the outside and secure with fasteners provided from the engine compartment side.
  8. Attach the short sleeve to the MAF and slip one of the elbows inside the sleeve facing rearward (see diagram).
  9. Connect the 3" long sleeve to the rearward facing elbow. Slip the second elbow through the round hole to the engine compartment and secure into the 3" sleeve.

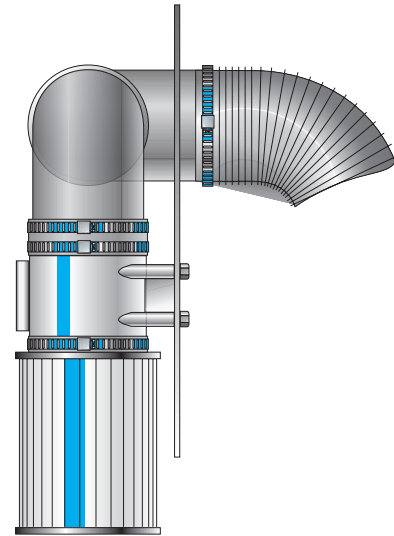

Fig. 13-b  
Front View

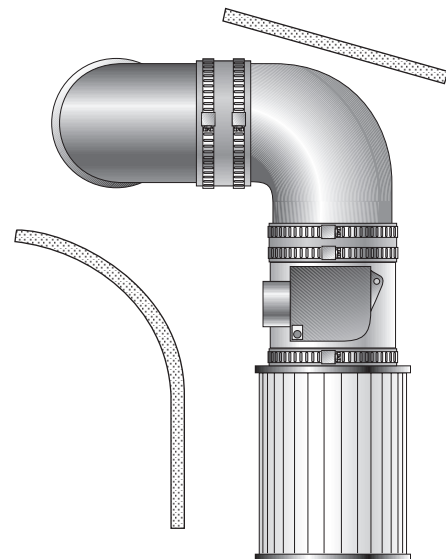

Fig. 13-c  
Right Side View

### 13. AIR FILTER ASSEMBLY, cont'd.

10. In the engine compartment, connect the flex hose from the elbow extending through the hole to the elbow on the supercharger.
11. Cut the MAF wires 3" to 4" away from the MAF connector.
12. Slip 1" long sections of the supplied shrink tubing over each wire before soldering.
13. Using the supplied wiring, solder wire extensions for the MAF and connector through the fender well. Position shrink tube over the solder joint and gently heat until the tube seals the joint.
14. Replace the inner fender lining.

### 14. IGNITION/BOOST CONTROL INSTALLATION (High Output and Cobra systems only)

- A. The Ignition/Boost Control unit has been prewired for installation convenience. Installation is a simple matter of disconnecting the stock connector at the ignition coil and plugging in the new adapter. Then plug the stock connector into the adapter.
- B. The next step is to provide a good ground for the black wire and mounting the box in as cool a place as possible under the hood. The box should be mounted with the aluminum cover on the bottom.
- C. Using the supplied 5/32" hose and 5/32" tee, connect the vent on the control unit to the FMU vacuum/pressure hose (see graphic at right).
- D. Route the Ignition/Boost Control wires through the firewall from the interior side. Mount the knob in an easily accessible place.
- E. Connect the wires to the plastic oval wiring connector on the Ignition/Boost Control unit using the snap-on connector supplied in the Ignition/Boost Control kit.

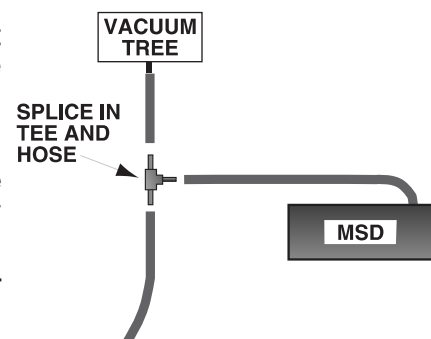

Fig. 14-a

**NOTE:** The wiring to the boost/control knob can be matched to either of the corresponding wires in the boost retard connector.

## 14. IGNITION/BOOST CONTROL INSTALLATION (High Output and Cobra systems only) cont'd.

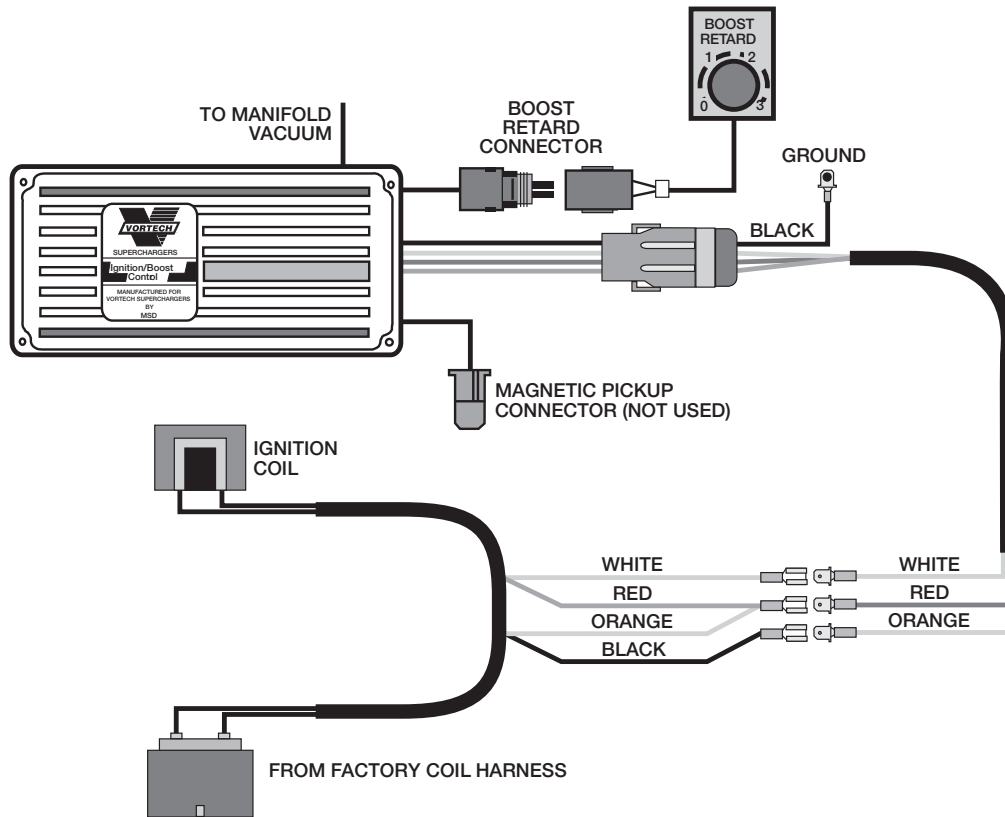

Fig. 14-b

## 15. IGNITION/BOOST CONTROL UNIT OPERATION (High Output and Cobra Systems only)

- The Ignition/Boost Control unit is designed to retard ignition in relation to boost.
- The unit is adjustable from 0° of ignition retard to 3° of ignition retard for each pound of boost, up to a maximum of 15°.
- Using the 1° per pound position as a starting place, adjust the ignition retard knob until just beyond the point of detonation. Use third gear for testing in a safe area or road. Adjust the retard according to changes in altitude and fuel quality.

**CAUTION:** It is extremely important that the boost retard never be turned to 0°. It is recommended that in stock street applications, the knob be positioned at 1° per lb. to start.

Example of Ignition Retard vs. Boost:

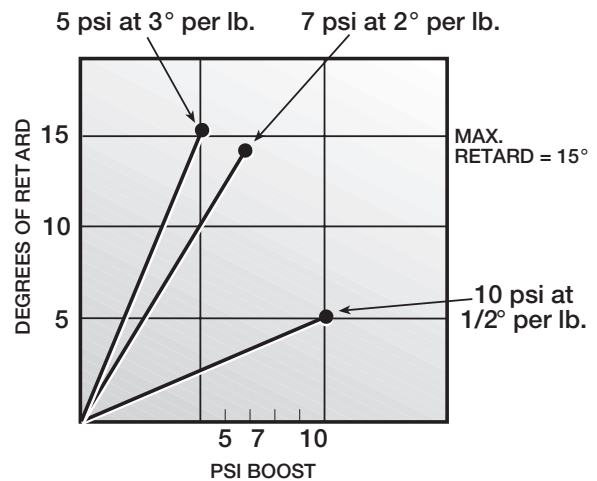

Fig. 15-a



**16. VORTECH BYPASS VALVE (H.O. and Cobra Systems Only. Skip to step H. for S.H.O. V-7 and Renegade applications)**

- A. Install the 90° inlet tube onto the supercharger with the fitting pointing down.
- B. Place the hoses as shown on the valve and secure it with the clamps provided.
- C. Attach one end of the small vacuum line onto the valve.
- D. Install the valve and hoses onto the inlet elbow fitting and secure with the clamps.
- E. Install the aluminum discharge tube (between the throttle body and supercharger) while guiding the hose onto the valve. Secure hoses with the clamps.
- F. Route the supplied 5/32" vacuum line and TEE so that you can splice into the FMU vacuum/pressure line.
- G. Make sure everything is secure and that no fuel lines or wires have been accidentally moved into harm's way.
- H. 1986-93 S.H.O. V-7 AND RENEGADE 5.0L KIT ONLY:

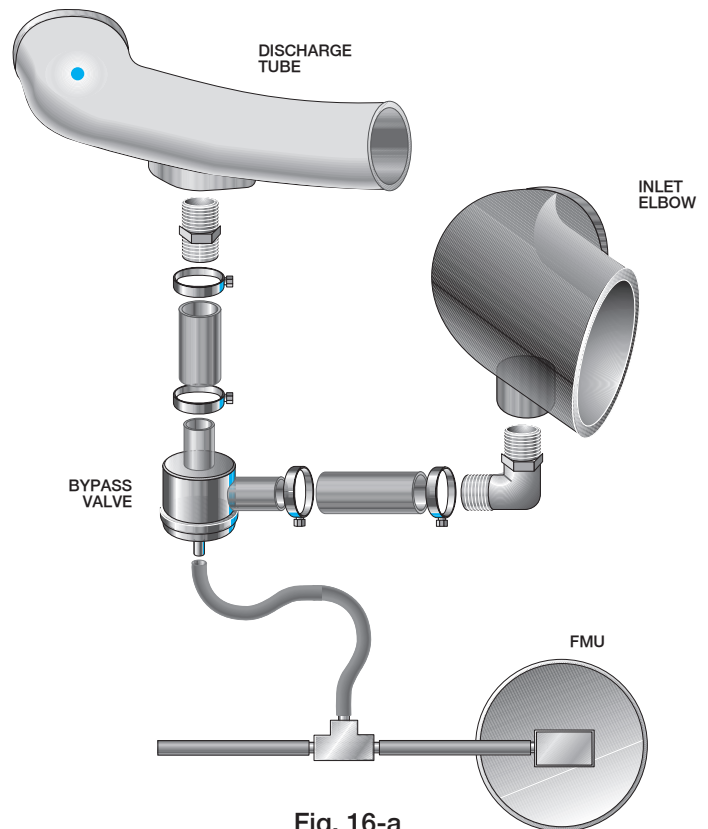

Fig. 16-a

1. Mount the supplied bypass valve to the aluminum discharge tube using the gasket and hardware.
2. Connect the supplied 1-3/4" or 2" diameter silicone sleeve to the outlet of the bypass valve.
3. Mount the aluminum discharge tube and valve assembly to the vehicle using the supplied silicone sleeves and clamps.
4. Align the bypass outlet sleeve to the inlet elbow boss located on the supercharger inlet elbow.

**NOTE:** MAF equipped applications require the bypass discharge air to be routed back into the air inlet so that proper air sampling can take place.

5. Align the discharge tube properly and tighten all clamps.
6. Route the supplied 1/4" vacuum line and TEE so that it is spliced into the FMU/vacuum line.

**WARNING:** Do not attempt to operate the vehicle until ALL components are installed and ALL operations are completed including the final check.

## 17. FINAL CHECK

- A. Reconnect the battery.
- B. If your vehicle has gone over 10,000 miles since its last spark plug change, you will need to change the spark plugs now before test driving the vehicle.
- C. Check all fittings, nuts, bolts and clamps for tightness. Pay particular attention to oil and fuel lines around moving parts, sharp edges and exhaust system parts. Make sure all wires and lines are properly secured with clamps or tie wraps.
- D. Check all fluid levels, making sure that your tank is filled with 91 octane or higher fuel before commencing test drive.
- E. Visually inspect the fan, belts and shroud for clearance before running the vehicle. Pay special attention to the upper radiator hose-to-belt and pulley clearance.
- F. Start engine and allow to idle a few minutes, then shut off.
- G. Recheck to be sure that no hoses, wires, etc. are near exhaust headers or moving parts and for signs of any fluid leakage. Check ignition timing to make sure it is set to stock specifications before commencing test drive.
- H. **PLEASE TAKE SPECIAL NOTE:** Operating the vehicle without ALL the subassemblies completely and properly installed may cause **FAILURE OF MAJOR COMPONENTS**.
- I. Test drive the vehicle.
- J. The supercharger drive belt stretches initially and will require adjustment between 250 and 400 miles.
- K. Read the **STREET SUPERCHARGER SYSTEM OWNER'S MANUAL (RACE OWNER'S MANUAL FOR THE RENEGADE KIT) AND RETURN THE WARRANTY REGISTRATION FORM** within thirty (30) days of purchasing your supercharger system to qualify (Renegade systems are designed for racing and come with a standard 6 month warranty).

### **For internally lubricated V3 units only**

This supercharger has been factory pre-filled with special Vortech synthetic lubricant. Oil does not need to be added to a brand new unit; however a fluid level check should be performed.

Prior to operating the supercharger on the vehicle and after installation onto the vehicle:

Remove the factory installed flat-head brass shipping plug (not the dipstick) from the top of the supercharger case. Replace the sealed shipping plug with the supplied "vented" plug. Do not operate the supercharger without it. Check the supercharger fluid level.

#### **Fluid level checking procedure:**

1. Ensure that the .06" copper sealing washer is located on the dipstick base.
2. Thread the clean dipstick into the unit until it seats.
3. Once the dipstick has seated, remove the dipstick from the unit. Fluid should register in the crosshatched area on the dipstick.
4. **DO NOT OVERFILL!!!** Drain excess fluid from the unit if it is above the maximum level on the dipstick.

Check the fluid level using the dipstick at least every 2,500 miles.

Initial supercharger fluid change must be performed at 2,500 miles. The supercharger fluid must be changed at least every 7,500 miles.

Drain the fluid, refill the unit with 4 oz. of Vortech V3 lubricating fluid and then confirm proper oil level using the dipstick. **DO NOT OVERFILL!!!**

**WARNING:** Use of any other fluid other than the special Vortech lubricant will void the warranty and may cause component failure.



**ENGINEERING, LLC**

**1650 PACIFIC AVENUE • CHANNEL ISLANDS, CA 93033-9901 • (805) 247-0226  
FAX (805) 247-0669 • [www.vortechsuperchargers.com](http://www.vortechsuperchargers.com) • M-F 8:00 AM - 4:30 PM PST**