

Ford 5.0L Mustang Supercharger System Installation Instructions

1994-1995 MODEL YEARS
50 SMOG STATE LEGAL PER CARB EO #D-213-17

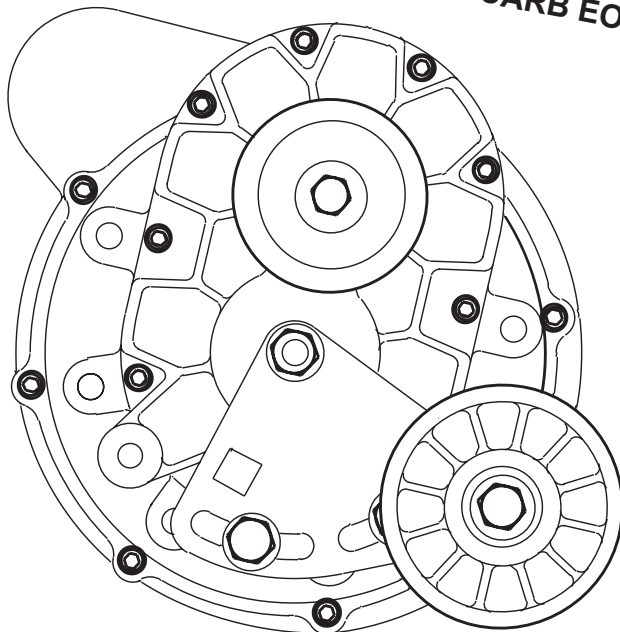

ENGINEERING, LLC

1650 PACIFIC AVENUE • CHANNEL ISLANDS, CA 93033-9901 • (805) 247-0226
FAX (805) 247-0669 • www.vortechsuperchargers.com • M-F 8:00 AM - 4:30 PM PST

FOREWORD

Proper installation of this supercharger kit requires general automotive mechanic knowledge and experience. Please browse through each step of this instruction manual *prior* to beginning the installation to determine if you should refer the job to a professional installer/technician. Please call Vortech Engineering for installers in your area.



Take note of the following before proceeding:

1. Proper installation of this supercharger kit requires general automotive mechanic knowledge and experience. Please browse through each step of this instruction manual prior to beginning the installation to determine if you should refer the job to a professional installer/technician. Please contact your dealer or Vortech Engineering for possible installers in your area.
2. **This product was designed for use on stock (*un-modified, OEM*) vehicles.** The PCM (*computer*), engine, transmission, drive axle ratios and tire O.D. must be stock. If the vehicle or engine has been modified in any way, check with Vortech prior to installation and use of this product.
3. Use only premium grade fuel with a minimum of 91 octane (*R+M/2*).
4. Always listen for any sign of detonation (*knocking/pinging*) and discontinue hard use (*no boost*) until the problem is resolved.
5. Vortech is not responsible for any clutch, transmission, drive-line or engine damage.

Exclusions from Vortech warranty coverage considerations include, but not limited to:

1. Neglect, abuse, lack of maintenance, abnormal operation or improper installation.
2. Continued operation with an impaired vehicle or sub-system.
3. The combined use of Vortech components with other modifications such as, but not limited to, exhaust headers, aftermarket camshafts, nitrous oxide, third party PCM programming or other such changes.

© 2008 VORTECH ENGINEERING, LLC

All rights reserved. No part of this publication may be reproduced, transmitted, transcribed, or translated into another language in any form, by any means without written permission of Vortech Engineering, LLC.

Table Of Contents

FOREWORD	<i>ii</i>
TABLE OF CONTENTS	<i>iii</i>
NOTICE	<i>iv</i>
TOOL & SUPPLY REQUIREMENTS	<i>v</i>
PARTS LIST - 94-95 HIGH OUTPUT MUSTANG	<i>vi</i>
PARTS LIST - 94-95 HIGH OUTPUT MUSTANG, V-3	<i>vii</i>
MSD IGNITION SYSTEM	<i>viii</i>
1. PREPARATION/REMOVAL.....	1
2. OIL FEED LINE.....	2
3. OIL DRAIN.....	3
4. FUEL MANAGEMENT UNIT.....	3
4.1 FUEL MANAGEMENT UNIT RECALIBRATION.....	4
5. FAN RELAY BOX RELOCATION.....	5
6. RADIATOR HOSE/AIR CONDITIONING LINE.....	5
7. SMOG PUMP HOSES.....	7
8. IGNITION MODULE RELOCATION.....	7
9. CRANKSHAFT AND WATER PUMP PULLEYS.....	8
10. MAIN BRACKET AND SUPERCHARGER MOUNTING PLATE.....	8
11. COOLANT HOSE REROUTING AND ENGINE COMPONENT REASSEMBLY.....	9
12. MASS AIR FLOW SENSOR RELOCATION.....	9
13. SUPERCHARGER MOUNTING AND ASSEMBLY, HOSE DRAIN AND INLET DUCT.....	10
14. ALTERNATOR AND MAIN ACCESSORY BELT INSTALLATION.....	11
15. DISCHARGE DUCT INSTALLTION.....	12
16. BYPASS VALVE INSTALLATION (High Output Kit Only).....	12
17. IGNITION/BOOST CONTROL INSTALLATION (High Output and Cobra Systems Only).....	13
18. T-REX FUEL PUMP INSTALLATION (High Output Systems Only).....	14
19. FINAL CHECK.....	16

NOTICE

This product is protected by state common law, copyright and/or patent. All legal rights therein are reserved. The design, layout, dimensions, geometry, and engineering features shown in this product are the exclusive property of Vortech Engineering, LLC. This product may not be copied or duplicated in whole or part, abstractly or fundamentally, intentionally or fortuitously, nor shall any design, dimension, or other information be incorporated into any product or apparatus without prior written consent of Vortech Engineering, LLC.

1994-1995 **FORD 5.0L MUSTANG**

Installation Instructions

50 State Smog Legal, as per CARB EO #D-213-17

Congratulations on selecting the best performing and best backed automotive supercharger available today... the VORTECH® V-2® Supercharger!

Before beginning this installation, please read through this entire instruction booklet and the Street Supercharger System Owner's Manual which includes the Limited Warranty Program, the Warranty Registration form and return envelope.

Vortech supercharger systems are performance improving devices. In most cases, increases in torque of 30 - 35% and horsepower between 35 - 45% can be expected with the boost levels specified by Vortech Engineering. This product is intended for use on healthy, well maintained engines. Installation on a worn-out or damaged engine is not recommended and may result in failure of the engine as well as the supercharger. Vortech Engineering is not responsible for engine damage.

Installation on new vehicles will not harm or adversely affect the break-in period so long as factory break-in procedures are followed.

For best performance and continued durability, please take note of the following key points:

1. Use only premium grade fuel 92 octane or higher (R+M/2).
2. The engine must have stock compression ratio.
3. If the engine has been modified in any way, check with Vortech prior to using this product.
4. Always listen for any sign of detonation (pinging) and discontinue hard use (no boost) until the problem is resolved.
5. Perform an oil and filter change upon completion of this installation and prior to test driving your vehicle. Thereafter, always use a high grade SF rated engine oil or a high quality synthetic, and change the oil and filter every 3,000 miles or less. Never attempt to extend the oil change interval beyond 3,000 miles, regardless of oil manufacturer's claims as potential damage to the supercharger may result.
6. Before beginning installation, replace all spark plugs that are older than 1 year or 10,000 miles with original heat range plugs as specified by the manufacturer and reset timing to factory specifications (follow the procedures indicated within the factory repair manual and/or as indicated on the factory underhood emissions tag). Do not use platinum spark plugs unless they are original equipment. Change spark plugs every at least 15,000 miles and spark plug wires at least every 50,000 miles.

TOOL & SUPPLY REQUIREMENTS

- Factory Repair Manual
- Timing light
- 3/8" Socket and Drive Set: SAE and metric
- 1/2" Socket and Drive Set: SAE and metric
- 3/8" and 1/2" Breaker Bars, 4" Extension
- 3/8"NPT Tap, 3/8-16 Tap and Handle
- Adjustable Wrench
- Open End Wrenches: 3/8", 7/16", 1/2", 9/16"
- "Slimline" 19mm - Snap-On#LTAM1719 or Craftsman 3/4" Tappet Wrench #44474
- Center Punch and a 5/8" Tapered Punch
- Large Screwdriver or Pry Bar
- Flat #2 Screwdriver
- Phillips #2 Screwdriver
- Heavy Grease
- Silicone Sealer
- Drill Motor
- 3/32", or 5/16", 7/16" Drill Bits
- #45 Torx Bit
- 1-1/16" Oil Sending Unit - Socket
- Ford Springlock 3/8" Fuel Fitting Disconnect Tool or Lisle A/C and Fuel Disconnect Tool Set #37000
- Lisle Door Upholstery Remover #35400 (Lisle tools available at Sears or Trak Auto)
- 5 Quarts SF Rated Quality Engine Oil
- Oil Filter and Wrench

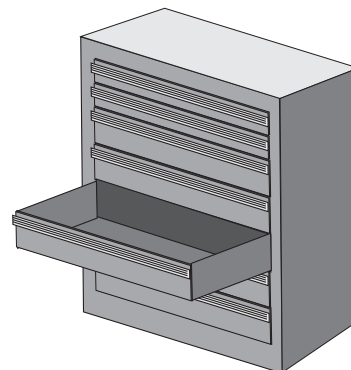

If your vehicle has in excess of 10,000 miles since its last spark plug change, then you will also need:

- Spark plug socket
- NEW spark plugs



1994-95 High Output Mustang

Part No. 4FG218-020SQ

PARTS LIST

IMPORTANT: Before beginning installation, verify that all parts are included in the kit. Report any shortages or damaged parts immediately.

PART NUMBER	DESCRIPTION	QUANTITY	PART NUMBER	DESCRIPTION	QUANTITY
2E328-110	V-2 SUPERCHARGER ASSEMBLY	1	4FG112-030	DISCHARGE ASSEMBLY	1
4FG111-021	MOUNTING BRACKET ASSEMBLY	1	7R002-044	#44 HOSE CLAMPS	2
4FG011-021	MOUNTING BRACKET	1	7R002-048	#48 HOSE CLAMPS	2
4FG010-033	MOUNTING PLATE	1	7S275-200	2-3/4" x 2" SLEEVE	1
4FG015-013	ALTERNATOR STAY	1	7S300-200	3" x 2" SLEEVE	1
4FG015-023	ALTERNATOR BRACKET	1	7P156-082	5/32" TEE	1
7A375-100	3/8-16 x 1" BOLTS	9	7R002-016	#16 HOSE CLAMPS	4
7K375-040	3/8"AN960 FLAT WASHERS	18	8D001-001	BYPASS VALVE	1
7L375-075	3/8" LOCK WASHERS	2	7U100-055	6" NYLON TIE-WRAPPS	6
7F375-016	3/8-16 NUTS	2	7U030-046	5/32" x 36" VACUUM LINE	1
7K312-001	5/16"AN WASHERS	2	7U034-016	1" x 3.5" HEATER HOSES	2
7K437-001	7/16"AN WASHER	1	4FG012-011	DISCHARGE DUCT	1
4FG017-011	ALTERNATOR STAY SPACER	1	4FG116-021	CRANK PULLEY ASSEMBLY	1
4FG017-021	LOWER ALTERNATOR STAY SPACER	1	4FG018-031	CRANK PULLEY	1
7A375-150	3/8-16 x 1-1/2" BOLTS	3	4FG016-081	WATER PUMP PULLEY	1
7A375-175	3/8-16 x 1-3/4" BOLT	1	7A375-126	3/8-16 x 1.25" BOLTS	4
7A375-224	3/8-16 x 2.25" BOLTS	3	7J375-044	3/8"SAE WASHERS	4
7A437-225	7/16-14 x 2-1/4" BOLT	1	7L375-075	3/8" LOCK WASHERS	4
7A375-400	3/8-16 x 4" BOLT	1	2A046-031	ACCESSORY BELT	1
7A312-100	5/16-18 x 1" BOLTS	2	2A048-575	SUPERCHARGER BELT	1
4FG017-031	SMOG PUMP SPACER	1	4FG130-026	OIL FEED ASSEMBLY	1
7A375-500	3/8-16 x 5" BOLT	1	7U030-026	1/4" x 29" OIL FEED HOSE	1
7A375-124	3/8-16 x 1-1/4" BOLT	1	7P125-103	1/8"NPT -4 x 45" MALE ELBOW	1
4FG150-012	IGNITION MODULE RELOCATION	1	7P250-066	#4 SWIVEL x 1/4" HOSE BARB FITTING	1
7E010-100	#12 x 1.0" SHEET METAL SCREW	1	7P250-067	1/4" BARB TO 1/4"NPT	1
4FA111-042	BELT TENSIONER ASSEMBLY	1	7P250-075	1/4"NPT 45° STREET ELBOW	1
7J012-092	12mm FLAT WASHERS	3	7P250-122	1/4" PIPE THREAD AN917 TEE	1
4FA011-032	BELT TENSIONER PLATE	1	7P250-123	1/4"NPT x 1-1/2" NIPPLE	1
7C012-065	12mm x 1.75" x 65mm BOLT	1	7P525-067	.500" CRIMP FERRULES	1
4FA016-170	WIDE PULLEY TENSIONER	1	7R003-003	14.5 STEPLESS CLAMP	1
2A017-011	IDLER PULLEY SPACER	1	5W011-008	1/2" x 24" WIRE LOOM	1
7C012-020	12mm x 1.75" x 20mm BOLTS	3	4FG238-068	FMU (WITH LINES)	1
7G010-175	12mm x 1.75" NUT	1	6Z110-116	12:1 FUEL MANAGEMENT UNIT	1
8F202-265	T-REX® ASSEMBLY	1	4FG135-056	MALE FUEL LINE ASSEMBLY	1
7F008-032	8-32 LOCK NUTS	8	4FG135-057	FEMALE FUEL LINE ASSEMBLY	1
7J008-001	#8 FLAT WASHERS	8	7U030-046	5/32" x 34" VACUUM TUBE	1
7P312-003	5/16" FEMALE FUEL CONNECTOR	1	7P156-082	5/32" TEE	1
7P312-001	FUEL FITTING ADAPTER	1	7U100-055	6" NYLON TIE-WRAP	1
7R004-002	17.0 STEPLESS CLAMPS	2	6Z170-040	10:1 RING SPACER ASSEMBLY	1
7U314-001	#8 LORD MOUNTS	4	4FG112-011	AIR INTAKE ASSEMBLY	1
5W001-001	WIRE TAP	1	4FG112-022	AIR INLET DUCT	1
7E010-050	#12 x 1/2" SHEET METAL SCREW	1	7U035-000	3-1/2" x 10" FLEX HOSE	1
7U375-135	ADHESIVE MOUNTING PADS	4	7R002-056	#56 HOSE CLAMPS	3
7U100-055	6" NYLON TIE-WRAPPS	6	7R002-052	#52 HOSE CLAMP	1
4FA020-030	T-REX PUMP TEMPLATE	1	8H040-030	AIR FILTER	1
8F101-200	T-REX WIRING ASSEMBLY	1	7A250-101	1/4-20 x 1" CAP SCREWS	4
8F002-265	T-REX INLINE 90° FUEL PUMP	1	7J250-001	1/4"SAE WASHERS	8
5W001-010	16-14GA FEMALE SLIDE	1	7F250-021	1/4-20 NYLOCK NUTS	4
5W001-002	FUSE TAP	1	7S325-100	3.25" x 1" SLEEVE	1
5W001-011	16-14GA EYELETS	2	7P375-050	3/8" HOSEMENDER	1
7U100-044	4" NYLON TIE-WRAPPS	6	7U030-056	3/8" x 1" PVC HOSE	1
7R004-001	15.7 STEPLESS CLAMPS	3	7P250-045	1/4"NPT x 3/8" FITTING	1
7U032-016	3/8" x 22" FUEL HOSE	1	4FA012-012	90° INTAKE ELBOW	1
7U031-018	5/16" x 16.5" FUEL HOSE	1	7S350-200	3-1/2" x 2" SLEEVE	1
4FG114-023	RADIATOR HOSE ASSEMBLY	1	5W122-025	12" 22GA GREY WIRE	1
7U133-048	5/8" MOLDED ELBOW HOSE	1	5W122-026	12" 22GA BLACK WIRE	1
7U100-066	11" TIE-WRAPPS	4	4FG110-050	MAF BRACKET ASSEMBLY	1
7R001-008	#8 HOSE CLAMPS	2	5W001-087	3/16" x 8" SHRINK TUBE	1
7R003-015	15/16" ADEL CLAMP	1	5A101-003	STAND ALONE ASSEMBLY	1
4FG130-036	OIL DRAIN ASSEMBLY	1	7P156-082	5/32" TEE	1
7U030-036	1/2" x 19" OIL DRAIN HOSE	1	5A002-002	WIRING HARNESS	1
7P375-017	3/8"NPT x 1/2" STRAIGHT HOSE BARB	1	5A001-001	STAND ALONE IGNITION RETARD	1
7R001-008	#8 STAINLESS HOSE CLAMPS	2	7U030-046	5/32" x 36" VACUUM LINE	1
			7U375-001	2" x 5" VELCRO-HOOK	1
			7U375-002	2" x 5" VELCRO-LATCH	1
			5W001-009	16-14GA MALE SLIDE	1



1994-95 High Output Mustang, V-3

Part No. 4FG218-020L

PARTS LIST

IMPORTANT: Before beginning installation, verify that all parts are included in the kit. Report any shortages or damaged parts immediately.

PART NUMBER	DESCRIPTION	QUANTITY	PART NUMBER	DESCRIPTION	QUANTITY
2F328-050	V-3 SUPERCHARGER ASSEMBLY	1	4FG112-030	DISCHARGE ASSEMBLY	1
4FG111-021	MOUNTING BRACKET ASSEMBLY	1	7R002-044	#44 HOSE CLAMPS	2
4FG011-021	MOUNTING BRACKET	1	7R002-048	#48 HOSE CLAMPS	2
4FG010-033	MOUNTING PLATE	1	7S275-200	2-3/4" x 2" SLEEVE	1
4FG015-013	ALTERNATOR STAY	1	7S300-200	3" x 2" SLEEVE	1
4FG015-023	ALTERNATOR BRACKET	1	7P156-082	5/32" TEE	1
7A375-100	3/8-16 x 1" BOLTS	9	7R002-016	#16 HOSE CLAMPS	4
7K375-040	3/8"AN960 FLAT WASHERS	18	8D001-001	BYPASS VALVE	1
7L375-075	3/8" LOCK WASHERS	2	7U100-055	6" NYLON TIE-WRAP	6
7F375-016	3/8-16 NUTS	2	7U030-046	5/32" x 36" VACUUM LINE	1
7K312-001	5/16"AN WASHERS	2	7U034-016	1" x 3.5" HEATER HOSES	2
7K437-001	7/16"AN WASHER	1	4FG012-011	DISCHARGE DUCT	1
4FG017-011	ALTERNATOR STAY SPACER	1	4FG116-021	CRANK PULLEY ASSEMBLY	1
4FG017-021	LOWER ALTERNATOR STAY SPACER	1	4FG018-031	CRANK PULLEY	1
7A375-150	3/8-16 x 1-1/2" BOLTS	3	4FG016-081	WATER PUMP PULLEY	1
7A375-175	3/8-16 x 1-3/4" BOLT	3	7A375-126	3/8-16 x 1.25" BOLTS	4
7A375-224	3/8-16 x 2.25" BOLTS	3	7J375-044	3/8"SAE WASHERS	4
7A437-225	7/16-14 x 2-1/4" BOLT	1	7L375-075	3/8" LOCK WASHERS	4
7A375-400	3/8-16 x 4" BOLT	1	2A046-031	ACCESSORY BELT	1
7A312-100	5/16-18 x 1" BOLTS	2	2A048-575	SUPERCHARGER BELT	1
4FG017-031	SMOG PUMP SPACER	1	4FG238-068	FMU (WITH LINES)	1
7A375-500	3/8-16 x 5" BOLT	1	6Z110-116	12:1 FUEL MANAGEMENT UNIT	1
7A375-124	3/8-16 x 1-1/4" BOLT	1	4FG135-056	MALE FUEL LINE ASSEMBLY	1
4FG150-012	IGNITION MODULE RELOCATION	1	4FG135-057	FEMALE FUEL LINE ASSEMBLY	1
7E010-100	#12 x 1.0" SHEET METAL SCREW	1	7U030-046	5/32" x 34" VACUUM TUBE	1
4FA111-042	BELT TENSIONER ASSEMBLY	1	7P156-082	5/32" TEE	1
7J012-092	12mm FLAT WASHERS	3	7U100-055	6" NYLON TIE-WRAP	1
4FA011-032	BELT TENSIONER PLATE	1	6Z170-040	10:1 RING SPACER ASSEMBLY	1
7C012-065	12mm x 1.75" x 65mm BOLT	1	4FG112-011	AIR INTAKE ASSEMBLY	1
4FA016-170	WIDE PULLEY TENSIONER	1	4FG112-022	AIR INLET DUCT	1
2A017-011	IDLER PULLEY SPACER	1	7U035-000	3-1/2" x 10" FLEX HOSE	1
7C012-020	12mm x 1.75" x 20mm BOLTS	3	7R002-056	#56 HOSE CLAMPS	3
7G010-175	12mm x 1.75" NUT	1	7R002-052	#52 HOSE CLAMP	1
8F202-265	T-REX® ASSEMBLY	1	8H040-030	AIR FILTER	1
7F008-032	8-32 LOCK NUTS	8	7A250-101	1/4-20 x 1" CAP SCREWS	4
7J008-001	#8 FLAT WASHERS	8	7J250-001	1/4"SAE WASHERS	8
7P312-003	5/16" FEMALE FUEL CONNECTOR	1	7F250-021	1/4-20 NYLOCK NUTS	4
7P312-001	FUEL FITTING ADAPTER	1	7S325-100	3.25" x 1" SLEEVE	1
7R004-002	17.0 STEPLESS CLAMPS	2	7P375-050	3/8" HOSEMENDER	1
7U314-001	#8 LORD MOUNTS	4	7U030-056	3/8" x 1" PVC HOSE	1
5W001-001	WIRE TAP	1	7P250-045	1/4"NPT x 3/8" FITTING	1
7E010-050	#12 x 1/2" SHEET METAL SCREW	1	4FA012-012	90° INTAKE ELBOW	1
7U375-135	ADHESIVE MOUNTING PADS	4	7S350-200	3-1/2" x 2" SLEEVE	1
7U100-055	6" NYLON TIE-WRAP	6	5W122-025	12" 22GA GREY WIRE	1
4FA020-030	T-REX PUMP TEMPLATE	1	5W122-026	12" 22GA BLACK WIRE	1
8F101-200	T-REX WIRING ASSEMBLY	1	4FG110-050	MAF BRACKET ASSEMBLY	1
8F002-265	T-REX INLINE 90° FUEL PUMP	1	5W001-087	3/16" x 8" SHRINK TUBE	1
5W001-010	16-14GA FEMALE SLIDE	1	5A101-003	STAND ALONE ASSEMBLY	1
5W001-002	FUSE TAP	1	7P156-082	5/32" TEE	1
5W001-011	16-14GA EYELETS	2	5A002-002	WIRING HARNESS	1
7U100-044	4" NYLON TIE-WRAP	6	5A001-001	STAND ALONE IGNITION RETARD	1
7R004-001	15.7 STEPLESS CLAMPS	3	7U030-046	5/32" x 36" VACUUM LINE	1
7U032-016	3/8" x 22" FUEL HOSE	1	7U375-001	2' x 5" VELCRO-HOOK	1
7U031-018	5/16" x 16.5" FUEL HOSE	1	7U375-002	2' x 5" VELCRO-LATCH	1
4FG114-023	RADIATOR HOSE ASSEMBLY	1	5W001-009	16-14GA MALE SLIDE	1
7U133-048	5/8" MOLDED ELBOW HOSE	1	4FG112-011	AIR INTAKE ASSEMBLY	1
7U100-066	11" TIE-WRAP	4	009035	V-3 LUBE	1
7R001-008	#8 HOSE CLAMPS	2			
7R003-015	15/16" ADEL CLAMP	1			

SPECIAL NOTICE CONCERNING THE

MSD IGNITION SYSTEM

The MSD Boost Timing Master, manufactured by Autotronic Controls Corporation, included in this kit is serviced exclusively by the manufacturer. Autotronic Controls Corporation warrants this product to be free from defects in material and workmanship under normal use and if properly installed for a period of one (1) year from the date of purchase. In case of malfunction, this unit will be repaired free of charge according to the terms of the warranty. If found to be defective as mentioned above, it will be repaired or replaced if returned prepaid along with proof of date of purchase. This shall constitute the sole remedy of the purchaser and the sole liability of Autotronic Controls Corporation and/or Vortech Engineering, LLC. To the extent permitted by law, the foregoing is exclusive and in lieu of all other warranties or representations whether expressed or implied, including any implied warranty of merchantability or fitness. In no event shall Autotronic Controls Corporation and/or Vortech Engineering, LLC, be liable for labor charges, special or consequential damages.

When returning this unit for service, proof of purchase must be supplied for warranty verification. After the warranty period has expired, repair service is charged between a minimum and maximum charge. In either case, please send the unit pre-paid with proof of purchase to the attention of:

**Autotronic Controls Corporation
Customer Service Department
12120 Esther Lama
Suite #114
El Paso, Texas, 79936
Phone: (915) 855-7123
Fax: (915) 857-3344
www.msdition.com**

The repaired unit will be returned as soon as possible after receipt, COD for any charges. Be sure you include a detailed account of any problems experienced, the type of vehicle and any modifications.

Should you have any technical or installation questions regarding this unit, contact Vortech Engineering, LLC, directly at (805) 247-0226.

1. PREPARATION/REMOVAL

- A. Disconnect the battery negative cable.
- B. Remove all of the components that lead to the throttle body including the mass air flow (MAF) sensor, air filter assembly and rubber bellows. Separate the MAF sensor from the air filter assembly and set aside.
- C. Remove the air temperature sensor from the bellows.
- D. Loosen the crank pulley and water pump pulley bolts.
- E. Remove the accessory belt.
- F. Remove the relay box that is mounted next to the radiator recovery tank. Carefully remove the electrical plug and set aside.
- G. Remove the water pump pulley.
- H. Drain approximately one gallon of coolant from the radiator. Remove the upper radiator hose and set aside.
- I. Remove the belt tensioner assembly.
- J. Unplug the wire connections and remove the alternator assembly (make sure the battery is disconnected).
- K. Remove the smog pump hoses from the smog pump.
- L. Remove the smog pump and alternator brackets with the smog pump still attached.
- M. Remove the smog pump from the bracket.
- N. Remove the 5/8" heater hose that runs from the water pump to the manifold tube assembly, next to the water temperature sender (see Fig. 1-a).
- O. Remove the distributor shield and the passenger side spark plug wires at the distributor and set aside.
- P. Disconnect the water temperature sensor plug.
- Q. Carefully cut the steel tube that runs along the intake manifold (the tube where the hose was previously removed). Remove approximately 3-1/4" and discard the cut off piece (see Fig. 1-b).
- R. Remove the radiator cover by using a Lisle door upholstery remover tool and a phillips screwdriver.
- S. For component clearance, it is necessary to remove the air conditioning line clamps on the frame and tuck the hose on top of the frame rail.
- T. Remove the "S" shaped coolant hose that runs from the firewall to the steel tube above the intake manifold that was previously shortened (see Fig. 1-c).

NOTE: Refer to your Mustang Owner's Guide for helpful illustrations and descriptions of particular components.

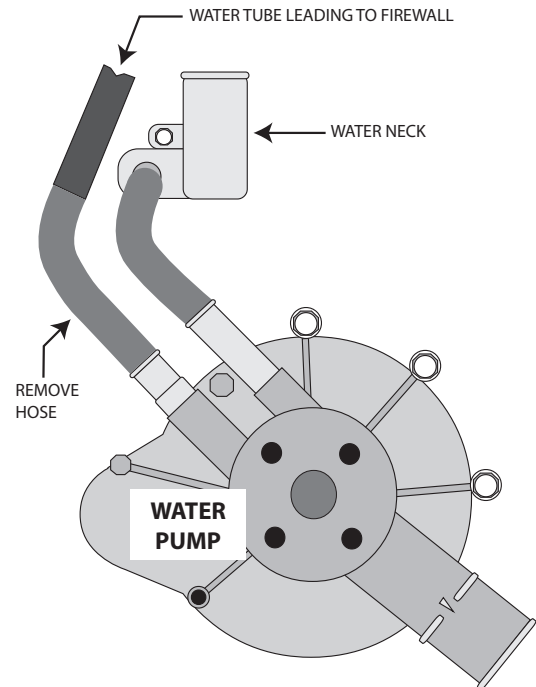

Fig. 1-a

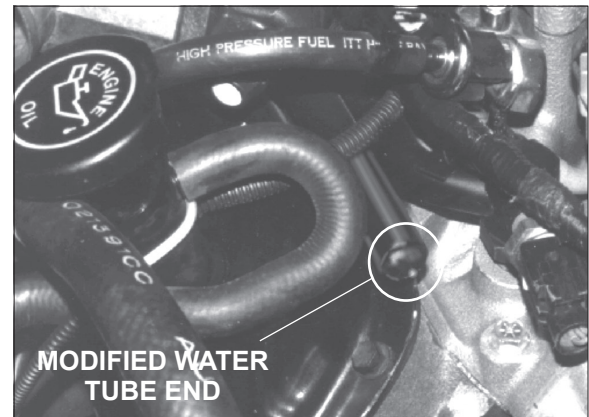

Fig. 1-b

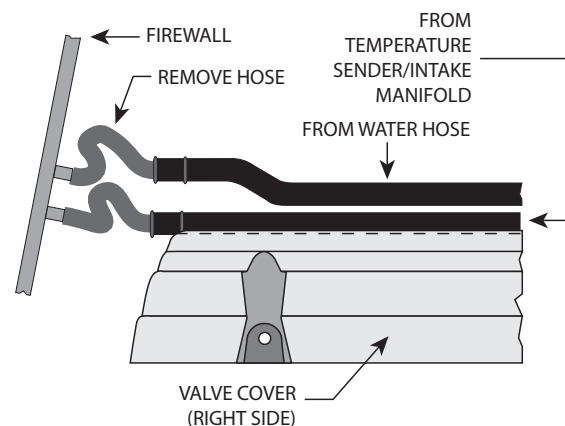

Fig. 1-c

2. OIL FEED LINE (ENGINE OIL-FED KITS ONLY. APPLICATIONS WITH V-3 SUPER-CHARGERS SKIP AHEAD TO STEP 4)

- A. Remove the oil filter for access to the oil pressure sender. Remove the oil pressure sender and install the tee fitting so that it points up and forward, towards the radiator at the 10 o'clock position.
- B. Install 45° elbow into the end of the tee fitting positioned as shown in the graphic. Reinstall the oil pressure sending unit and wiring.
- C. Thread the oil feed line onto the TEE and route towards the engine oil fill port.
- D. Fit a 24" length of the 1/2" flex loom onto the oil line for abrasion protection.

NOTE: Cover the end of the fitting with a plastic bag to keep debris from entering the system.

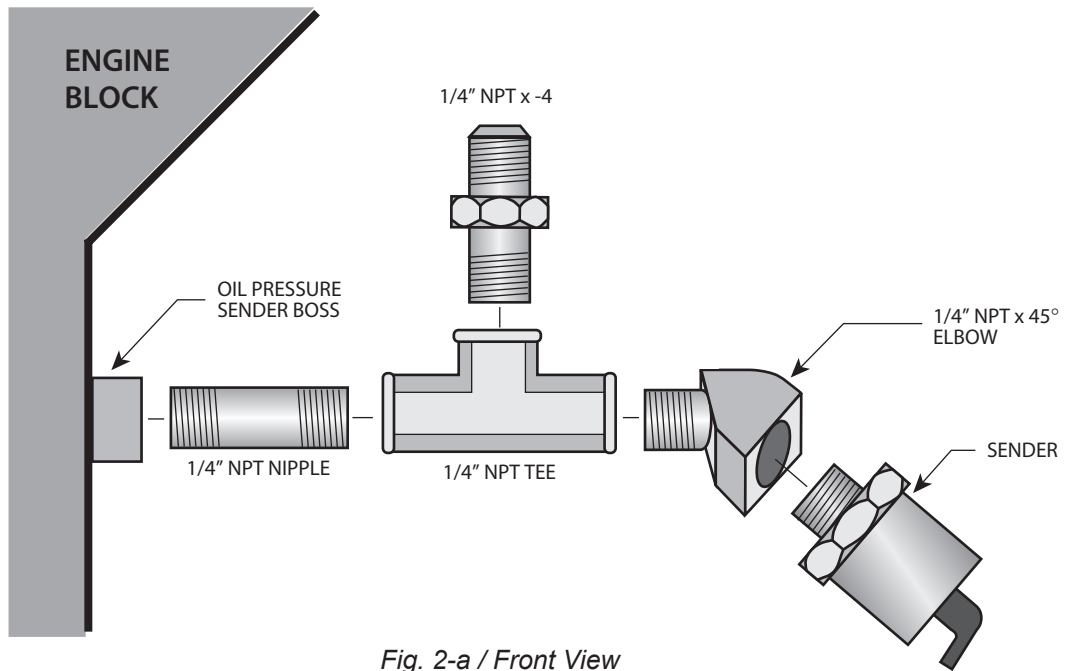

Fig. 2-a / Front View

WARNING: DO NOT use any sealant or sealing tape on oil feed lines. Use ONLY engine oil on oil line threads or damage to the supercharger is possible and the warranty will be void!

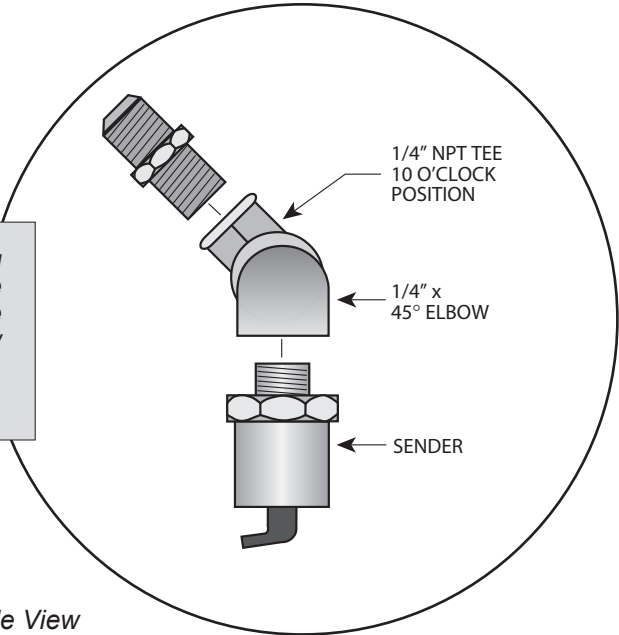

Fig. 2-b / Driver's Side View

3. OIL DRAIN (ENGINE OIL-FED KITS ONLY. APPLICATIONS WITH V-3 SUPER-CHARGERS SKIP AHEAD TO STEP 4)

- A. To provide an oil drain for the supercharger, it is necessary to make a hole in the oil pan. Locate and mark hole as per diagram. It is best to punch the hole rather than drill.
- B. Remove paint around the hole area.
- C. Use a small center punch to perforate the pan and expand the hole. Switch to a larger diameter punch and expand the hole further to approximately 9/16" diameter. Most punches are made from hexagon material and may be placed in a socket with an extension to make this procedure easier.
- D. Tap the hole with a 3/8" NPT tap approximately 1/4" deep. Pack the flutes of the tap with heavy grease to hold chips. Use a small magnet to check for any stray chips.

NOTE: This method of rolling over the lip of the hole and tapping it works very well if carefully done and should cause no problems.

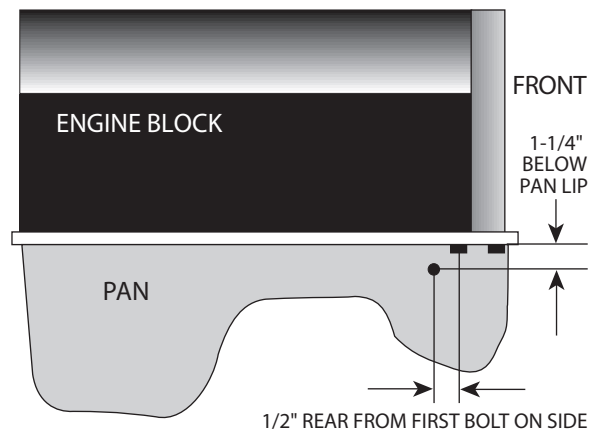

Fig. 3-a

- E. Thoroughly clean the threaded area. Apply a small amount of silicone sealer to the new threads and thread in the oil drain assembly. Apply more sealer to the 3/8" NPT hose fitting and secure in hole. Make sure a seal is formed all around the fitting.
- F. Drain the engine oil and change the filter.

4. FUEL MANAGEMENT UNIT

- A. Disconnect the fuel rail **return** line behind the shock tower and at the manifold fuel rail with spring lock disconnect tool. Remove the fuel line. The return line **does not** have a pressure test fitting on it. (It is the smaller of the two lines).
- B. Attach the supplied 14" fuel line to the center fitting on the management unit (FMU). Mount the FMU against the passenger side inner fender panel in between the shock tower and the firewall using sheet metal screws. Coil the units 14" return line upward, forming a loop back down to the stock return line. (See Fig. 4-a.)
- C. Connect the FMU input hose from the fitting on the side of the FMU to the return line coming from the fuel rail regulator fitting as shown in Figs. 4-b, 4-c on the following page.
- D. Using the stock hose mount on the shock tower, secure the fuel lines away from the exhaust manifold with the tie wraps provided.

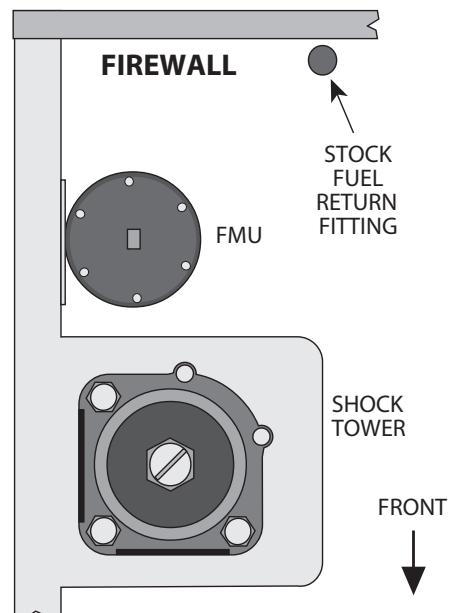

Fig. 4-a

4. FUEL MANAGEMENT UNIT, cont'd.

- E. Attach the 5/32" vacuum hose assembly to the vacuum tree on the intake manifold (see Fig. 4-d). The assembly will form a TEE in between the tree and the fuel regulator.
- F. Route the assembly to the fitting on top of the FMU.

NOTE: Make sure all connections are sealed properly with the cable ties provided to avoid vacuum leaks.

- G. Reuse the fuel retainer clips from the stock return fuel line at the manifold.

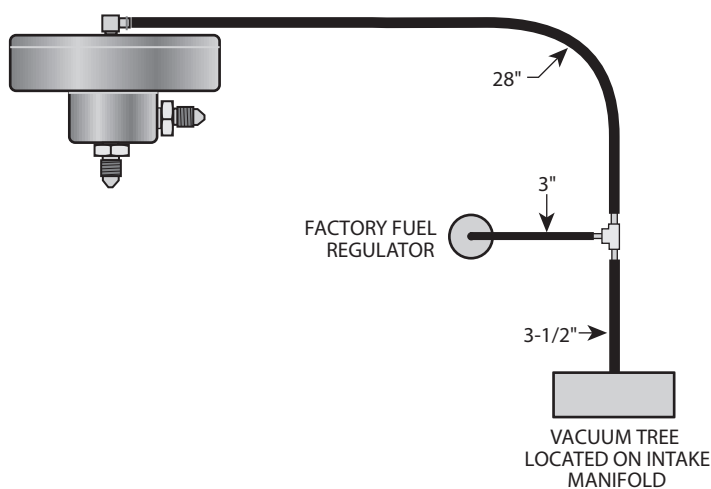

Fig. 4-d

4.1 FUEL MANAGEMENT UNIT RECALIBRATION

(For Cobra models or vehicles equipped with 24 lb. injectors only.)

WARNING: Do not remove the four screws holding the valve body. Once taken apart, the valve would have to be replaced.

- A. Remove the six allen head screws on top of the fuel management unit (FMU). (See Fig. 4-e.)
- B. Remove the diaphragm and disk (and the ring, if equipped) from inside of the FMU.

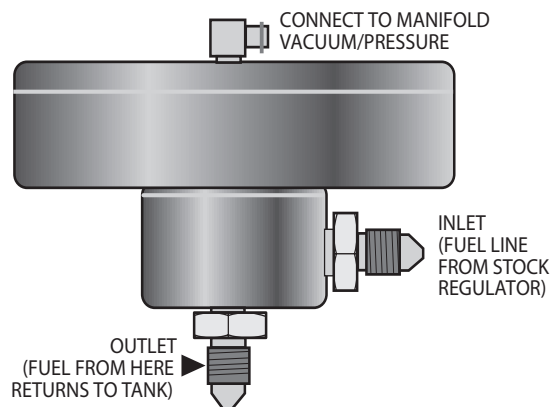

Fig. 4-b

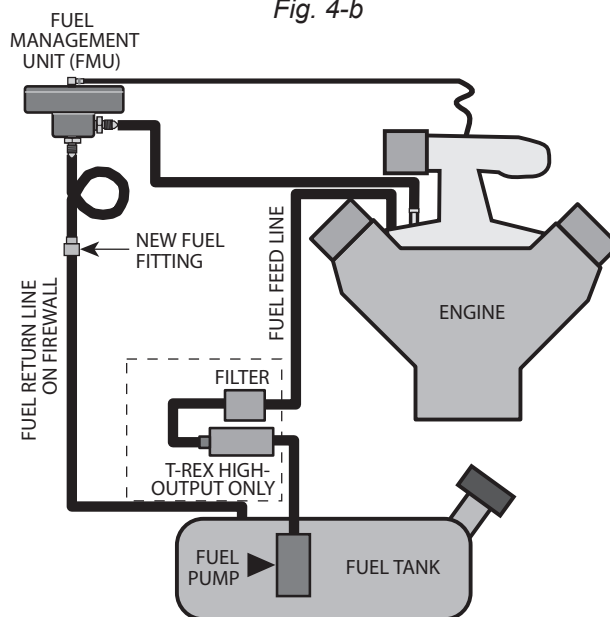

Fig. 4-c

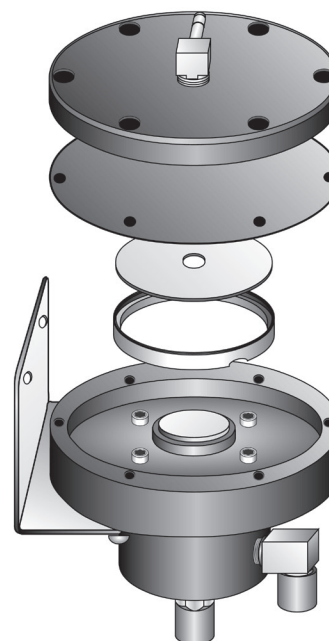

Fig. 4-e / FMU

4.1 FUEL MANAGEMENT UNIT RECALIBRATION, cont'd.

- C. Install replacement ring (with the notched part facing down) around the four screws inside the FMU.
- D. Place the new disk inside the ring on top of the piston.
- E. Install the new diaphragm and carefully line up holes to the body.
- F. Reinstall the FMU cover with the six allen head screws. **Do not overtighten the screws.** The correct torque is 24 in/lbs (2 ft/lbs).

5. FAN RELAY BOX RELOCATION

- A. Modify the relay mount by removing 1/2" from the front end of the bracket that mounts to the radiator core support. Mark and drill two 1/4" holes located 5/8" towards the back of the original mounting holes (see Fig. 5-a).
- B. Trim a 2" x 1/2" section off of the plastic radiator cover piece to clear repositioned relay (see Fig. 5-b). Align relay and shroud.
- C. Reroute the electrical fan and coolant overflow wiring underneath the fan relay processor bracket for belt clearance.

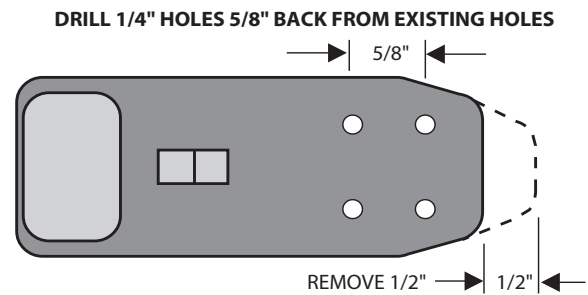
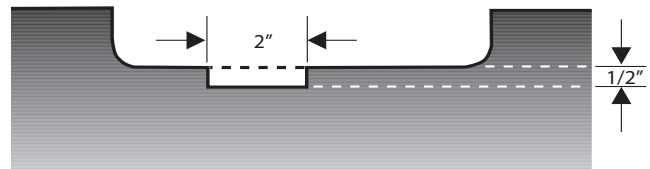

Fig. 5-a



PLASTIC RADIATOR COVER

Fig. 5-b

6. RADIATOR HOSE/AIR CONDITIONING LINE

- A. Trim 1-1/4" of hose from the radiator end of the upper radiator hose (straight portion) (see Fig. 6-a).
- B. Remove the air conditioning line support clamps near the radiator outlet so that the air conditioning lines may be bent. Reconnect the mounting tabs.
- C. Slightly bend the high pressure air conditioning line (the line with the pressure switch located on it) towards the radiator and around the radiator hose for clearance of the supercharger pulley and belt system. (See Figs. 6-b, 6-c.)

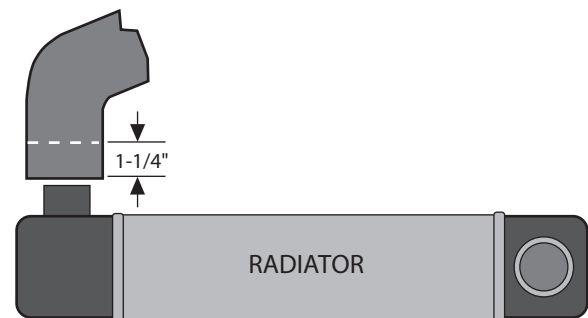

Fig. 6-a

NOTE: Air conditioning lines are under high pressure and the fluid is highly toxic; therefore, use extreme caution when bending the line to avoid kinking or breaking the line. Support the assembly as much as possible while bending for clearance.

6. RADIATOR HOSE/AIR CONDITIONING LINE, cont'd.

- D. Notch the radiator bracket to the frame for clearance of the air conditioning line. (See Fig. 6-d.)
- E. Reinstall fan relay, bracket and radiator cover piece.

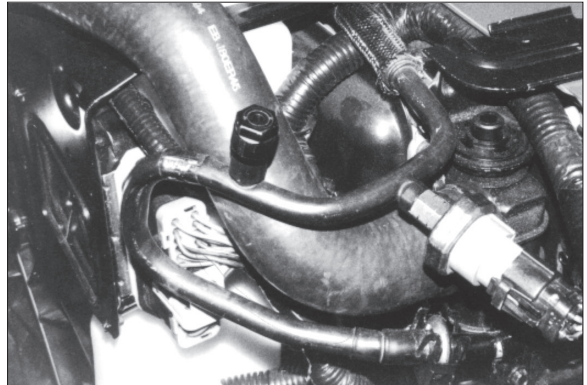

Fig. 6-b

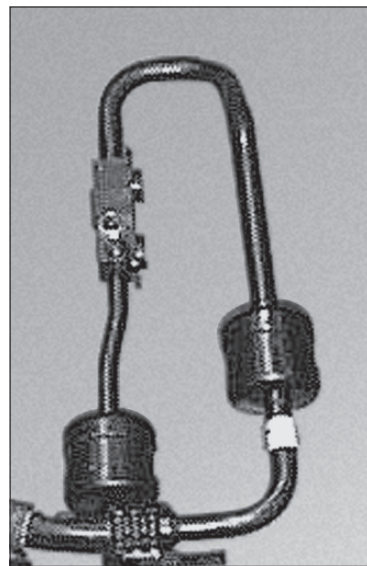

Fig. 6-c / Air Conditioning Line

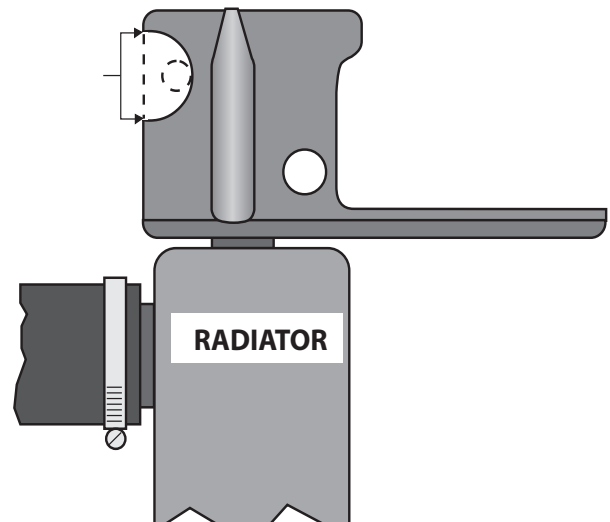

Fig. 6-d / Right Side View

7. SMOG PUMP HOSES

- A. Separate the check valve hose and exit hose from the diverter valve. (See Fig. 7-a.)
- B. Remove 1-3/4" from the end of the diverter valve exit hose and check valve hose.
- C. Trim 1" from the opposite end of the check valve hose.
- D. Remove 1-1/4" from the smog pump hose.
- E. Secure the hoses as shown using the stock clamps and supplied #16 clamps.

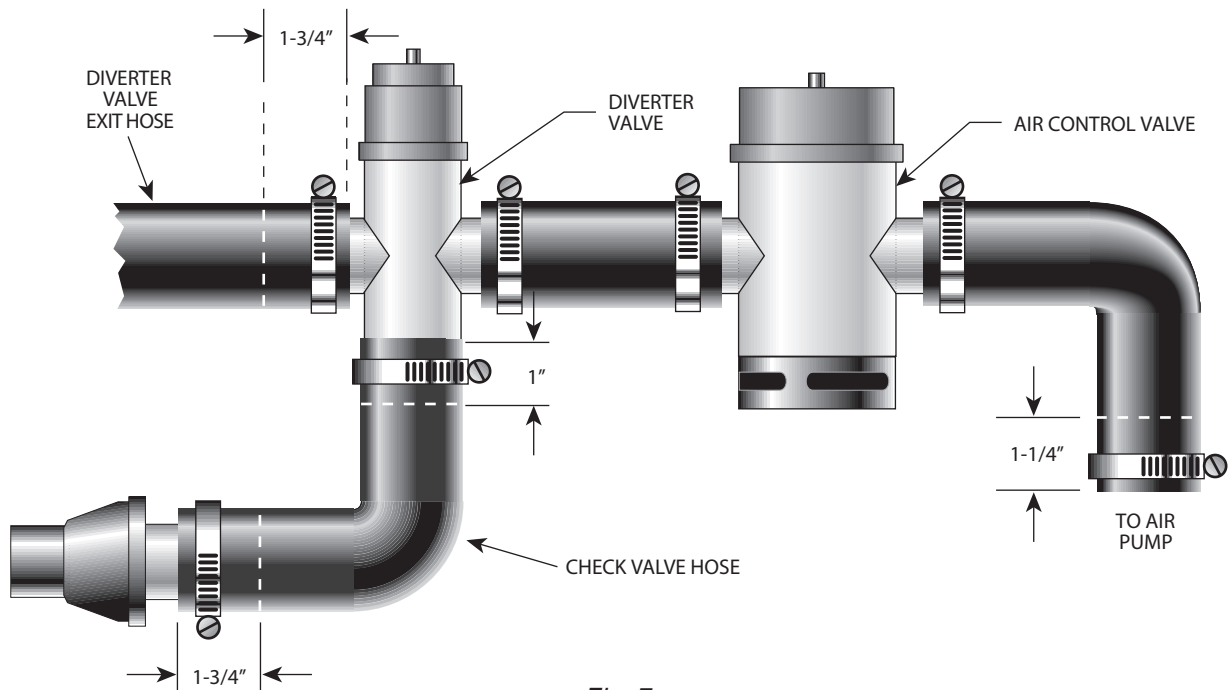

Fig. 7-a

8. IGNITION MODULE RELOCATION

- A. To ensure proper clearance for the intake duct, the TFI ignition module must be rotated. Carefully unwrap the wire loom running to the grey TFI module plug. Lengthen the wire assembly by pulling the TFI loom out of the main harness (approximately 7") until it meets the air temp and MAF connector (in main harness).
- B. Using the 7" length of 3/8" flex loom provided, rewrap the unwrapped wiring and connector.
- C. Using the original threaded hole closest to the shock tower, rotate the ignition module 180° and mount with the bolt and sheet metal screw provided (see Fig. 8-a).

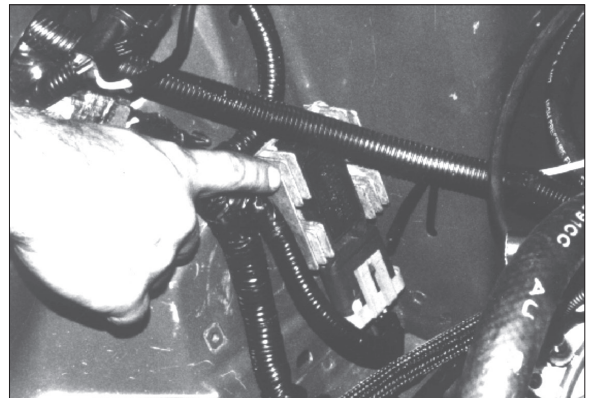

Fig. 8-a

9. CRANKSHAFT AND WATER PUMP PULLEYS

- A. Remove the crankshaft pulley.
- B. Place the Vortech crank pulley onto the crank balancer and secure with the four supplied grade 8 bolts and washers.
- C. Install the Vortech water pump pulley using stock fasteners.

NOTE: Tighten bolts progressively and evenly in a crisscross pattern so that pulleys align properly.

10. MAIN BRACKET AND SUPERCHARGER MOUNTING PLATE

- A. Sandwich the smog pump between the casting and front supercharger mounting plate using the five 3/8-16 x 1" bolts and AN washers. On the upper smog pump bolt hole use the 3/8-16 x 5" bolt, 3/8" nut and AN washer with .189 spacer behind the front plate and the 3/8-16 x 1-1/4" bolt and AN washer on the lower mount of the smog pump.
- B. Install the assembled bracket onto the engine using one 7/16-14 x 2-1/4" bolt and two 3/8-16 x 2-1/4" and one 3/8-16 x 1-1/2" bolt and AN washer.
- C. Connect the smog pump diverter inlet hose to the smog pump discharge.
- D. Mount the triangular shaped alternator bracket using two 5/16-18 x 1" bolts and AN washers as shown.
- E. Using the factory mounting bolt, mount the accessory belt tensioner onto the Vortech main bracket.

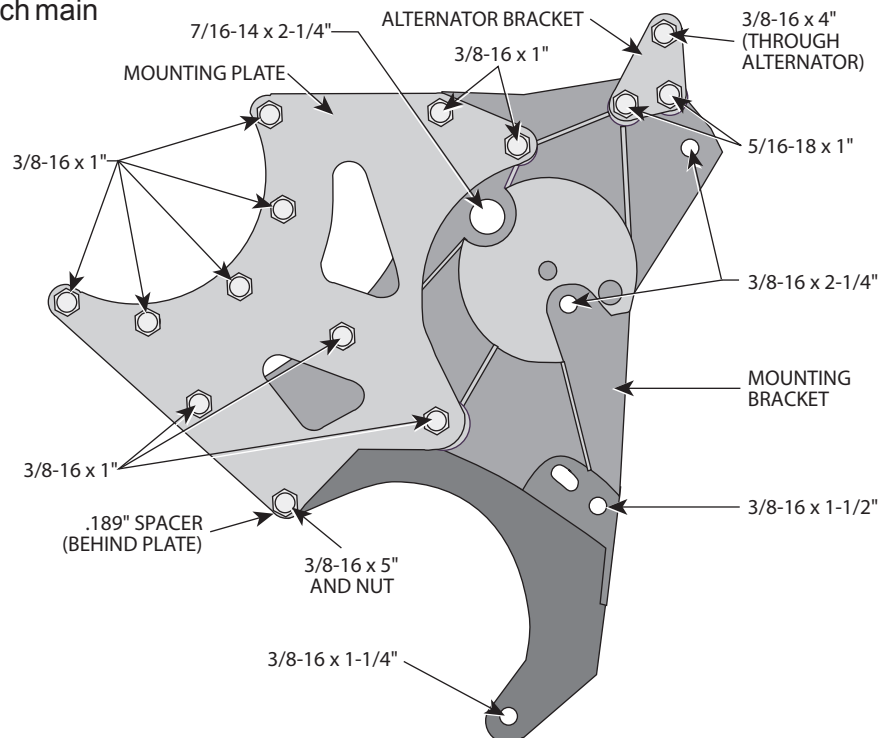

Fig. 10-a

11. COOLANT HOSE REROUTING AND ENGINE COMPONENT REASSEMBLY

- A. Attach the supplied 5/8" coolant hose with the molded elbow end to the heater fitting on the firewall. Secure with a hose clamp.
- B. Carefully route the coolant hose along the shock tower and fuel lines next to the oil fill pipe and secure with cable ties.
- C. Attach the coolant hose to the front supercharger mounting plate using the supplied #15 adel clamp and the 3/8" bolt as shown in the graphic. Install coolant hose and clamp onto the water pump fitting. Trim if necessary.

NOTE: Make sure that the hoses are routed smoothly with no kinks or sharp bends and away from all heat sources.

- D. Reconnect the spark plug wires to the distributor. Carefully rotate the temperature sender to allow as much clearance for the alternator as possible, reconnect the temperature sensor plug.

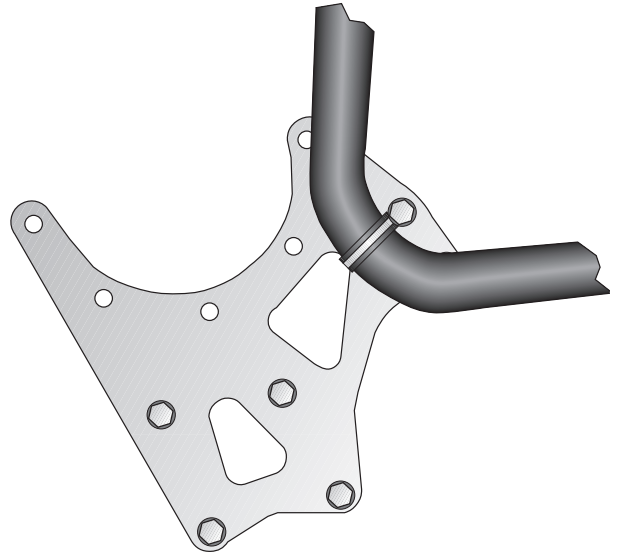

Fig. 11-a

12. MASS AIR FLOW SENSOR RELOCATION

- A. Remove the mass air flow (MAF) sensor and air temperature connector loom from the main harness.
- B. Cut the air temperature sensor wires 3" to 4" away from the air temperature connector. Using the supplied wiring, solder wire extensions (make sure the color of the wires match the main harness wire colors) to the cut harness. Slip two of the supplied one inch shrink sleeves onto each of the cut wires.
- C. Reattach the air temperature sensor connector by soldering it to the extended harness. Position the shrink sleeve sections over each of the solder joints. Gently heat until the tube seals the joint.
- D. Cover the wire assembly with the 18" flex loom.
- E. Remove the two 1/4-20 washers and nuts from the right lower fender valance and mount the MAF bracket on the existing studs using the same washers and nuts to fasten to the inner fender. (See Fig. 12-a.)

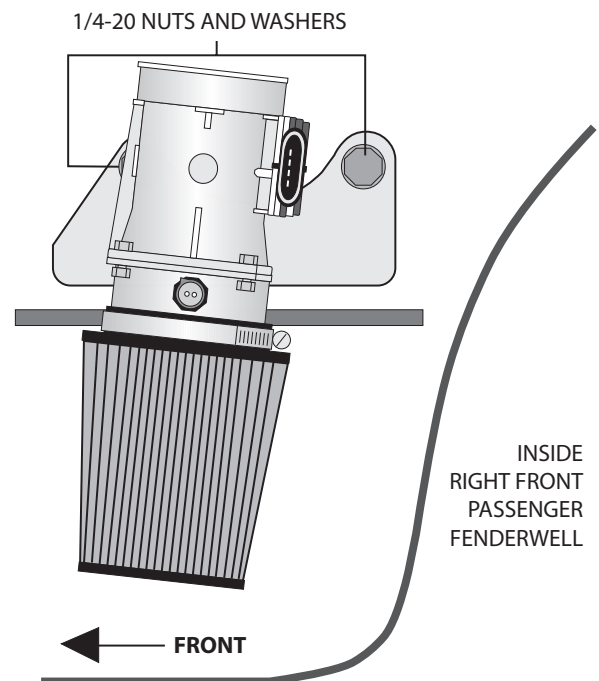

Fig. 12-a

12. MASS AIR FLOW SENSOR RELOCATION *cont'd.*

- F. Slide the 3-1/8" x 1" sleeve onto the stock mass air sensor. Slide the flex hose and #52 hose clamp over the assembly.
- G. Mount the hose and mass air assembly onto the mounting bracket using the four 1/4-20 bolts, washers and nylock nuts.
- H. Screw the air temperature sensor into the bracket and plug in the electrical connector for the MAF and the air temp sensor.
- I. Slide the air filter and clamp assembly onto the bracket and secure.

13. SUPERCHARGER MOUNTING AND ASSEMBLY, HOSE DRAIN AND INLET DUCT

- A. Slide the inlet duct along with the T-type clamp onto the supercharger inlet. (See Fig. 13-a.)
- B.* Place the oil drain hose onto the supercharger drain fitting and secure with a hose clamp. Arrange the clamp screw housing so it will not interfere with the mounting plate when installed.
- C.* Feed the oil drain hose around the side of the smog pump and down towards the oil pan fitting while lowering the supercharger into position.
- D. Secure the supercharger with four (4) 3/8-16 x 1" bolts and AN washers.
- E.* Connect the lower end of the oil drain hose to the fitting on the pan and secure with a hose clamp. Drain must be routed downhill with no kinks or dips. Trim hose if necessary.
- F. Place the supercharger belt idler assembly on the supercharger using the 12mm bolts and washers. Position the thin head bolt in the tensioner plate nearest the idler pulley.
- G. Attach the 3-1/2" elbow assembly and 3-1/2 x 2" sleeve to the supercharger inlet duct using the #56 clamps. Route the flex hose end through the opening in the fender apron and attach to the MAF sensor outlet. Secure hose to MAF with the supplied #52 clamp.
- H.** Secure the remote drain hose away from the belt and other hoses using tie-wraps.

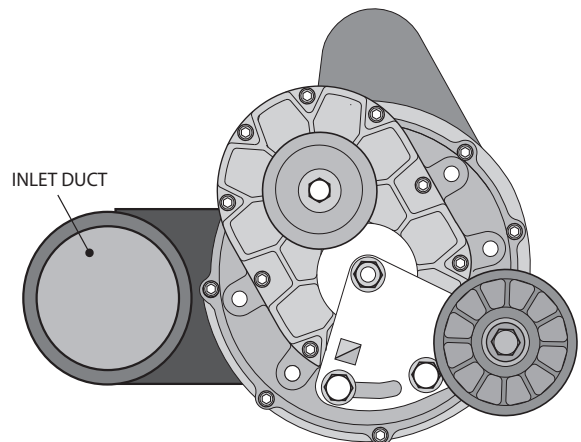

Fig. 13-a

* Applies to "engine oil-fed" units only. V-3 applications skip these steps.

** Applies to V-3 applications only

14. ALTERNATOR AND MAIN ACCESSORY BELT INSTALLATION

- A. Mount the alternator to the alternator bracket and main bracket using a 3/8-16 x 4" bolt and washer. Reconnect the two wiring plugs and battery lug to the alternator.
- B.* Thread the oil feed line onto the supercharger fitting.
- C. Route the coolant hose over the oil fitting/hose assembly.
- D. Mount the alternator stay to the supercharger and supercharger mounting plate using two 3/8-16 x 1-1/2" bolts and washers, 5/8" spacer and 5/16" spacer. Place the 5/8" spacer in between the upper supercharger mounting bolt hole and the alternator stay. Place the 5/16" spacer in between the upper supercharger mounting plate hole and the alternator stay (see Fig. 14-b). Bolt the alternator to the upper alternator stay slot using the 3/8-16 x 1-3/4" bolt, washer, lock washer and nut.
- E. Install the main accessory belt using a 3/8" breaker bar to rotate the tensioner clockwise, allowing the belt to fit over all of the pulleys. (See Fig. 14-a.)
- F. Mount the supercharger belt on the crank pulley and supercharger pulley with the tensioner routed according to the graphic. Tighten the belt using a 1/2" breaker bar, a 3/4" tappet or a 19mm thin wrench to tighten the bolts.

* Applies to "engine oil-fed" units only. V-3 applications skip these steps.

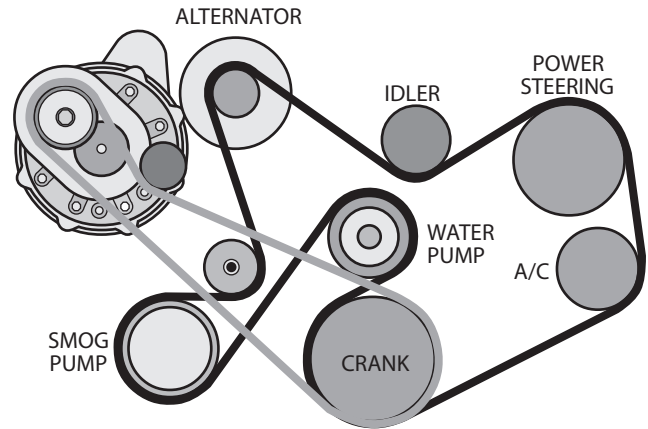

Fig. 14-a

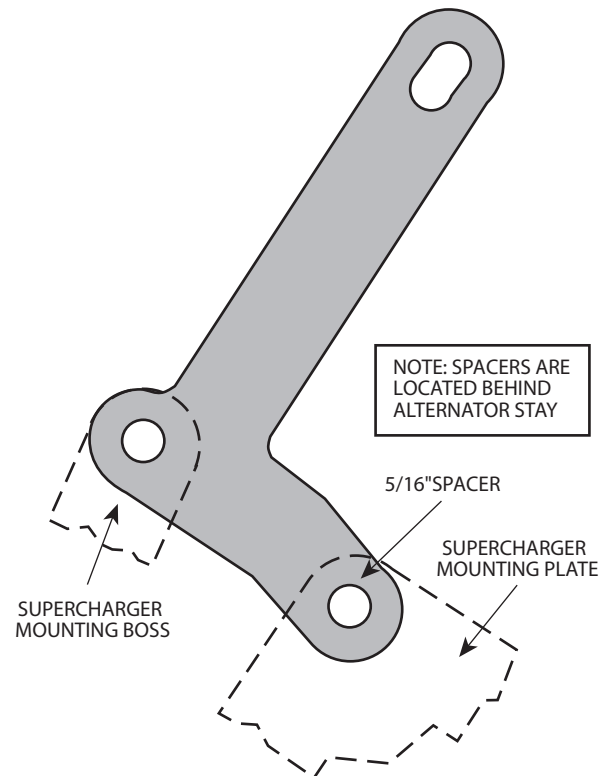

Fig. 14-b

15. DISCHARGE DUCT INSTALLATION

- A. Fit the 3" x 2" sleeve onto the throttle body and secure with the supplied #48 clamp. Loosely slide the remaining clamp onto the sleeve.
- B. Slide the 2-3/4" x 2" sleeve and clamps onto the discharge tube assembly.
- C. Fit the discharge tube onto the throttle body tube and slide the 2-3/4" x 2" sleeve onto the supercharger discharge port, tighten down the #44 clamps on both sides.
- D. Using the 3/8" hose mender and length of 3/8" hose supplied, fit into the stock PCV hose and route to the barb fitting on the inlet duct of the supercharger. (See Fig. 15-a.)

NOTE: In some instances you may have to trim or shorten these ducts for fit and ease of installation due to differences in components.

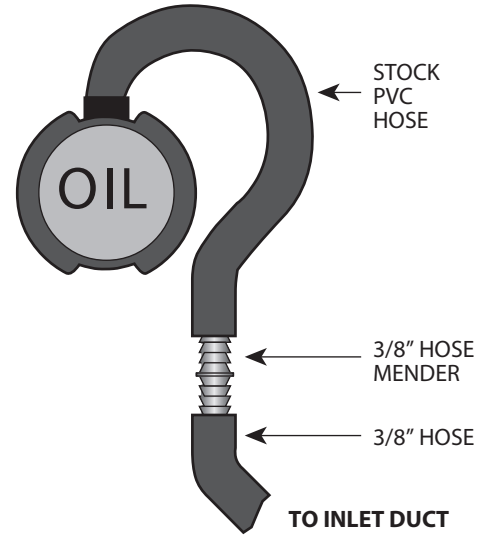

Fig. 15-a

16. BYPASS VALVE INSTALLATION (High-Output System Kit Only)

- A. Slide the 1" x 3-1/2" hose onto the bypass valve. Secure with #16 hose clamps. (See Fig. 16-b.)
- B. Slide the 1" x 2-1/2" hose onto the discharge duct and bypass valve. Secure with hose clamps. Trim hose length if necessary.
- C. Route the 5/32" vacuum line to the bypass valve and FMU TEE as shown (See Fig. 16-a.)
- D. Using the supplied TEE and length of hose, cut the hose 4" from the FMU.
- E. Install the tee fitting and connect the hose to the bypass valve.

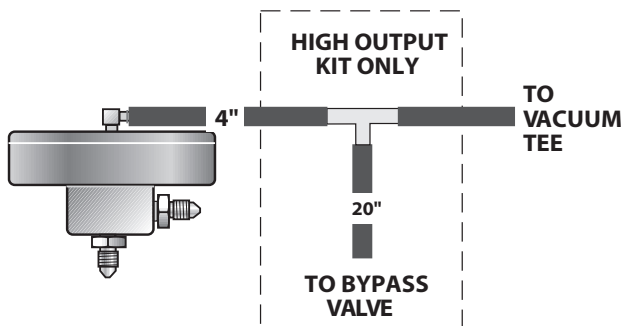

Fig. 16-a

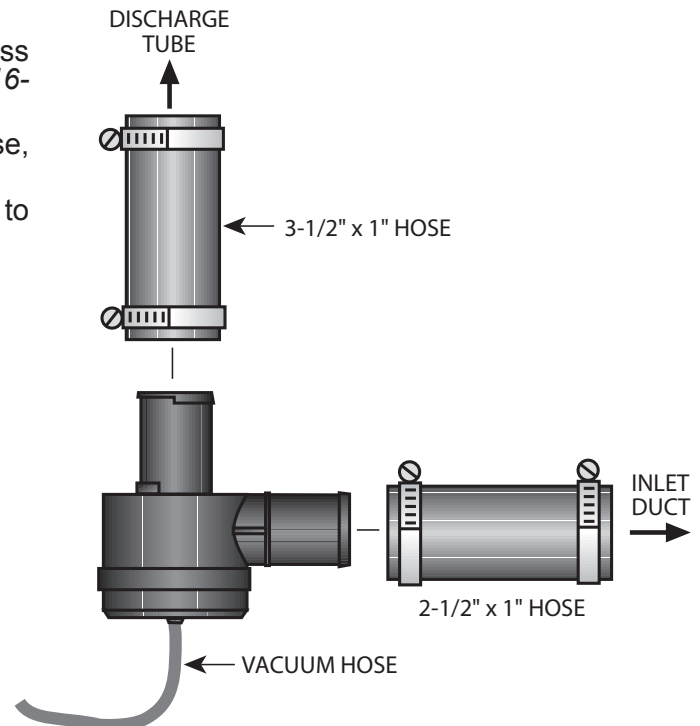

Fig. 16-b

17. IGNITION/BOOST CONTROL INSTALLATION (High-Output and Cobra Systems Only)

- A. The Ignition/Boost Control unit has been prewired for installation convenience. Installation is a simple matter of disconnecting the stock connector at the ignition coil and plugging in the new adapter. Then plug the stock connector into the adapter.
- B. The next step is to provide a good ground for the black wire and mounting the box in as cool a place as possible under the hood. The box should be mounted with the aluminum cover on the bottom.
- C. Using the supplied 5/32" hose and 5/32" TEE, connect the vent on the control unit to the bypass valve vacuum pressure hose. (See Fig. 17-a.)
- D. Route the Ignition/Boost Control wires through the firewall from the interior side. Mount the knob in an easily accessible place.
- E. Connect the wires to the plastic oval wiring connector on the Ignition/Boost unit using the Snap-on connector supplied in the Ignition/Boost Control kit.

NOTE: The wiring to the Boost/Control knob can be matched to either of the corresponding wires in the boost retard connector.

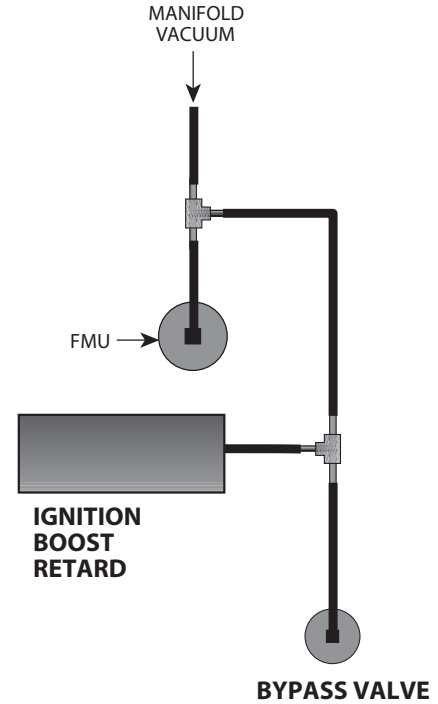
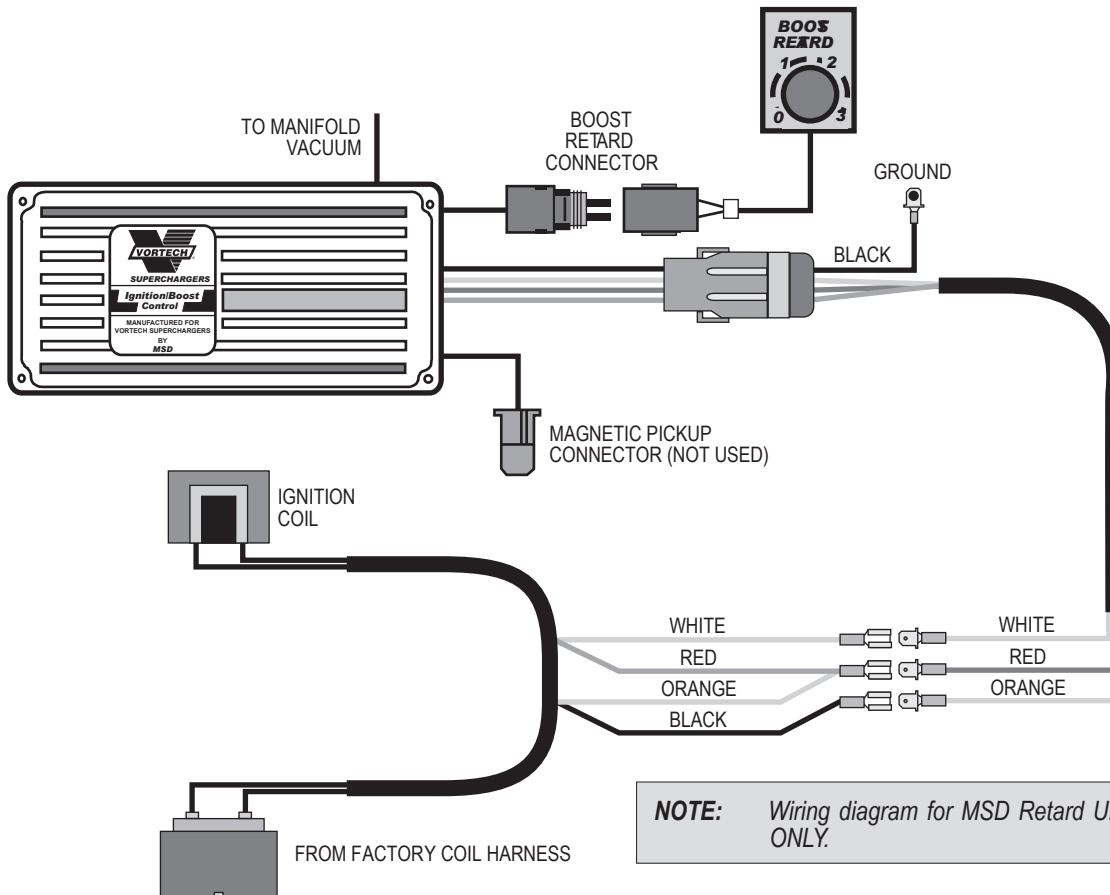

Fig. 17-a



NOTE: Wiring diagram for MSD Retard Unit ONLY.

Fig. 17-b

18. T-REX® FUEL PUMP INSTALLATION (High-Output System Only)

- A. Remove spare tire, etc. from trunk.
- B. Trim "Cut-Out" from the template provided in the kit and place over spare tire hold-down. Centerpunch and drill the four 3/16" holes in the trunk floor.
- C. Jack up the rear of the car and support with jack stands.
- D. Mount the T-Rex fuel pump to the underside of the tire well with the rubber mounts, adel clamps and fasteners provided. Refer to the graphic on the following page.
- E. Remove the hose assembly and fitting that connects the fuel tank to the fuel filter inlet. Carefully rotate the stock hose assembly previously disconnected from the filter downward 90°.
- F. Connect the T-Rex inlet hose assembly to the stock female supply hose fitting by gently pushing the fittings together and making sure they are locked.
- G. Fasten the extended feed line clear of the filter by looping the two 11" cable ties through the front slot on the fuel filter mount, being careful not to kink the line.
- H. Plug the female connector onto the fuel filter inlet making sure the hose assembly clears all exhaust tubing and sharp objects.

NOTE: Use extreme caution when routing fuel lines. Make sure fuel lines are located away from hot exhaust pipes and sharp edges on vehicle underbody.

- I. Mark and drill a 1/8" hole and mount the relay inside the trunk in position as shown in the template. Use the sheet metal screw provided.
- J. From relay terminal #85, tap the yellow wire into the stock fuel pump harness in the trunk near the right tail light. Tap into the purple wire with the supplied scotch lock. (On some model years, wire may be brownish-green.)
- K. Connect the short red wire on relay terminal #8 to the (+) terminal on the fuel pump.
- L. Connect the longer black wire from the (-) terminal on the fuel pump to a clean ground.
- M. Connect the short black wire to a clean ground from relay terminal #86 (relay screw mount works well).
- N. Route the remaining long red wire from relay terminal #30 up to the high current fuse panel located in the engine compartment. Using a solderless connector, connect the supplied fuse holder and fuse to the end of the wire. Crimp the fuse wire to the large ring terminal and attach the accessory (+) battery lug.

18. T-REX® FUEL PUMP INSTALLATION cont'd.

NOTE: Make sure everything is secure and away from all moving parts or exhaust pipes. Make sure no wires will rub on sharp edges. After you have activated the pump, check for any leaks and correct if necessary.

Route the red power lead from the relay #30 under the car through the drive shaft tunnel and secure with ties! Take care to avoid sharp edges and not damage the wire insulation. Mount relay in the right rear corner of the spare tire well. Make sure all wires are connected as per the relay schematic below. Provide a good ground connection free of rust and paint for both the pump and relay.

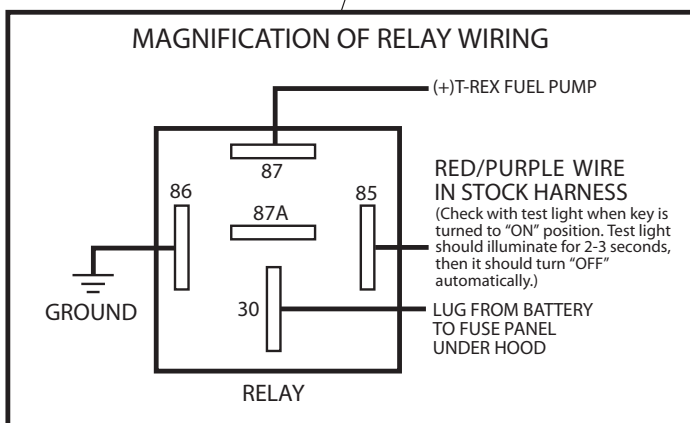
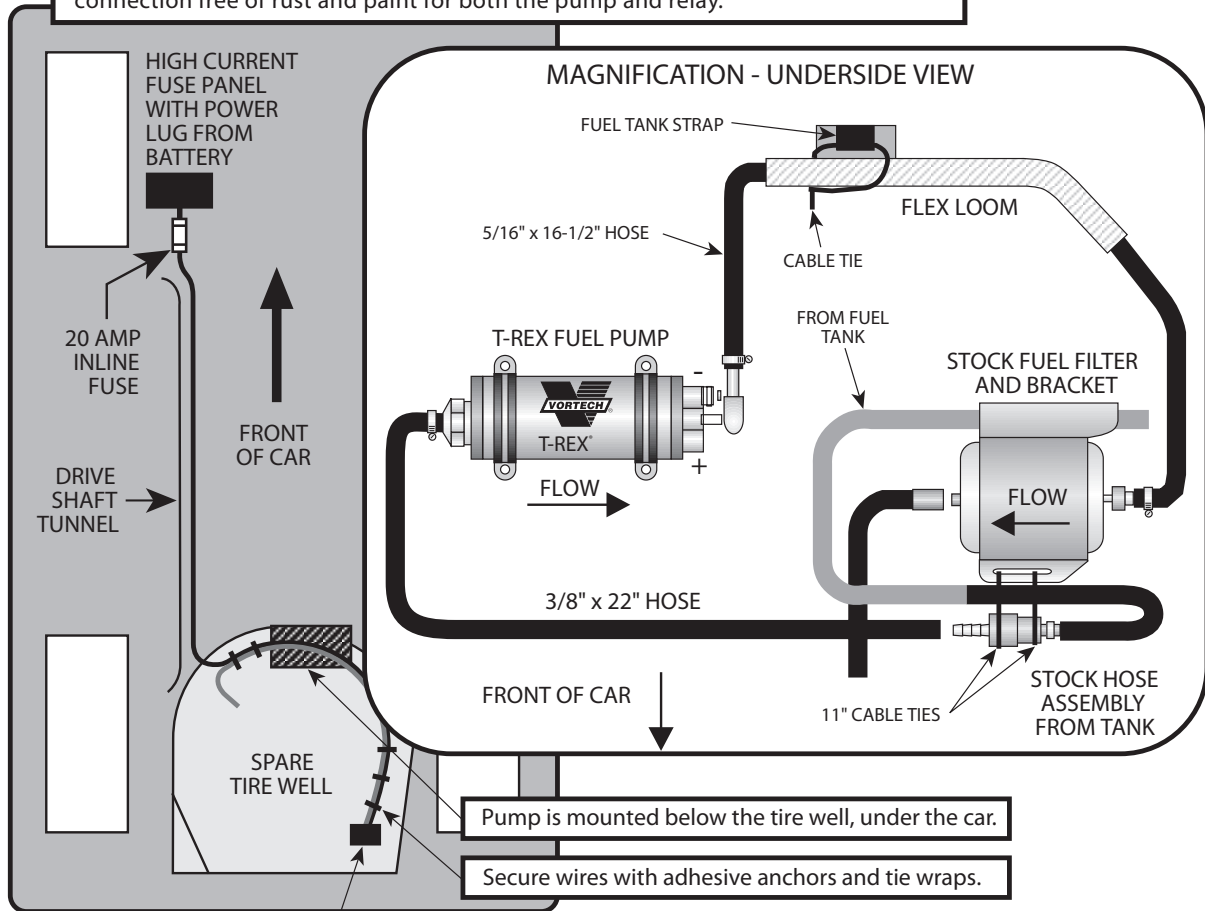

Fig. 18-a

WARNING: Do not attempt to operate the vehicle until ALL components are installed and ALL operations are completed including the final check.

19. FINAL CHECK

- A. Reconnect the battery.
- B. If your vehicle has gone over 10,000 miles since its last spark plug change, you will need to change the spark plugs now before test driving the vehicle.
- C. Check all fittings, nuts, bolts and clamps for tightness. Pay particular attention to oil and fuel lines around moving parts, sharp edges and exhaust system parts. Make sure all wires and lines are properly secured with clamps or tie wraps.
- D. Check all fluid levels, making sure that your tank(s) is filled with 92 octane or higher fuel before commencing test drive.
- E. Start engine and allow to idle a few minutes, then shut off.
- F. Recheck to be sure that no hoses, wires, etc. are near exhaust headers or moving parts and for signs of any fluid leakage. Check ignition timing to make sure it is set to stock specifications before commencing test drive.
- G. **PLEASE TAKE SPECIAL NOTE:** Operating the vehicle without ALL the subassemblies completely and properly installed may cause **FAILURE OF MAJOR COMPONENTS.**
- H. Test drive the vehicle.
- I. The supercharger drive belt stretches initially and will require adjustment between 250 and 400 miles.
- J. Read the **STREET SUPERCHARGER SYSTEM OWNER'S MANUAL AND RETURN WARRANTY REGISTRATION FORM** within thirty (30) days of purchasing your supercharger system to qualify.

For internally lubricated V3 units only

This supercharger has been factory pre-filled with special Vortech synthetic lubricant. Oil does not need to be added to a brand new unit; however a fluid level check should be performed.

Prior to operating the supercharger on the vehicle and after installation onto the vehicle:

Remove the factory installed flat-head brass shipping plug (not the dipstick) from the top of the supercharger case. Replace the sealed shipping plug with the supplied "vented" plug. Do not operate the supercharger without it. Check the supercharger fluid level.

Fluid level checking procedure:

1. Ensure that the .06" copper sealing washer is located on the dipstick base.
2. Thread the clean dipstick into the supercharger unit it seats.
3. Once the dipstick has seated, remove the dipstick from the unit. Fluid should register in the cross-hatched area on the dipstick.
4. **DO NOT OVERFILL!!!** Drain excess fluid the unit if it is above the maximum level on the dipstick.

Check the fluid level using the dipstick at least every 2,500 miles.

Initial supercharger fluid change must be performed at 2,500 miles. The supercharger fluid must be changed at least every 7,500 miles.

Drain the fluid, refill the unit with 4 oz. of Vortech V3 lubricating fluid and then confirm proper oil level using the dipstick. **DO NOT OVERFILL!!!**

WARNING: Use of any other fluid other than the special Vortech lubricant will void the warranty and may cause component failure.



ENGINEERING, LLC

1650 PACIFIC AVENUE • CHANNEL ISLANDS, CA 93033-9901 • (805) 247-0226
FAX (805) 247-0669 • www.vortechsuperchargers.com • M-F 8:00 AM - 4:30 PM PST