



STEEDA

Billet Transmission Shifter Bracket

For: 2013 Ford Focus ST
Installation Instructions For Kit #555-7242



- A qualified technician should be used if you are not confident after carefully reading through the instructions.

Installation of the Steeda Billet Transmission Shifter Bracket

1. Place the car on a level surface and apply the parking brake. Shift the car into Neutral.
2. Remove the factory airbox assembly (see figure 1) by:
 - a. Loosening the hose clamp securing the rubber intake tube to the plastic intake tube.
 - b. Disconnect the electrical connector for the MAP sensor. See figure 1.
 - c. Unclip the rubber strap securing the cold air feed tubes from their mount at the cold air feed coming from the grille. See figure 1.
 - d. Gently pull up on the airbox and dislodge the rubber grommets (beneath the airbox) from their locating holes on the chassis. Lift out the entire assembly, with cold air feed tubes attached, in one piece.

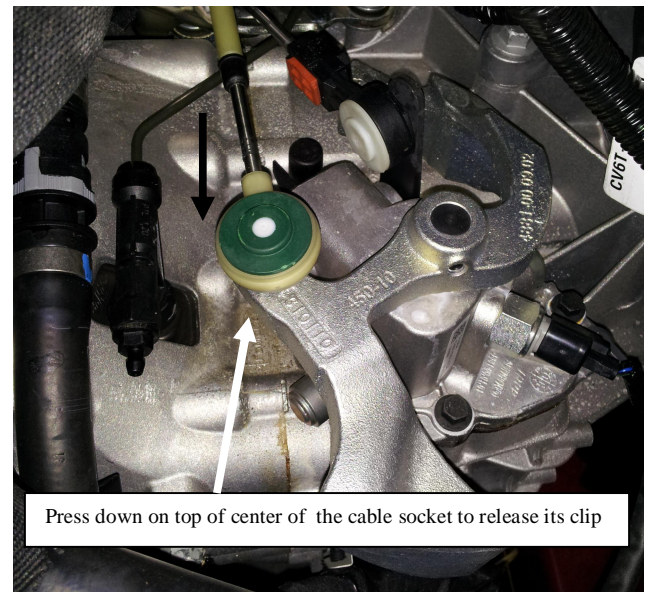
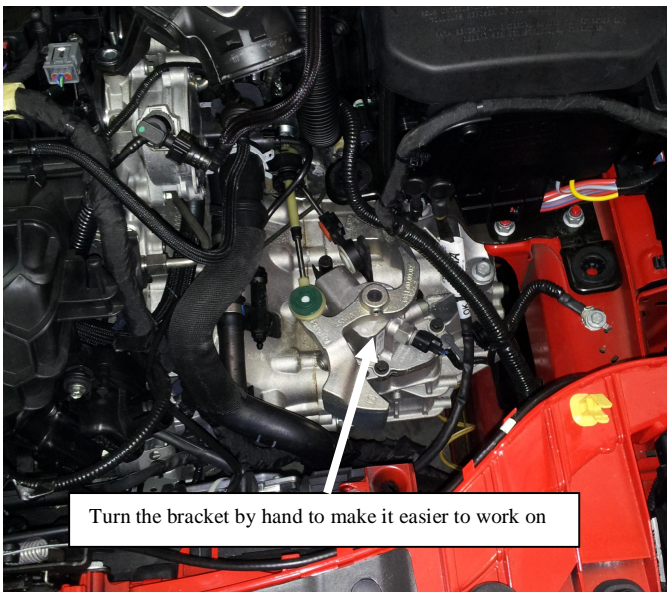

3. With the bracket assembly now exposed, shift the transmission input bracket so that the shifter cable socket is easiest to access. This can be done by turning the bracket by hand. See figure 2.
4. **!!!This is a delicate/difficult step!!!** Take a small center punch, or small Phillips head screwdriver, and firmly press down on the rubber center portion on top of the shifter cable socket. See figure 3. This will

release the internal clip securing the socket to its respective ball stud. With your other hand, using a small forked prying tool (or a large flat tip screwdriver), pop the socket/cable off the ball stud by prying up between the bottom of the socket and the bracket. DO NOT force the socket off, IF the internal clip is fully released, the socket will come off with relatively little force.

5. Install the Steeda bracket as seen in figures 4 and 5.
6. Apply a small amount of Loctite to the threads of the two provided countersink head screws.
7. Install the stamping and the two countersink head screws under the bracket as seen in figure 4. Tighten the screws to 10ft-lbs, or until the gap between the bracket and stamping is closed.
8. Install the provided Nylon lock nut over the longer of the two screws as seen in figure 4.

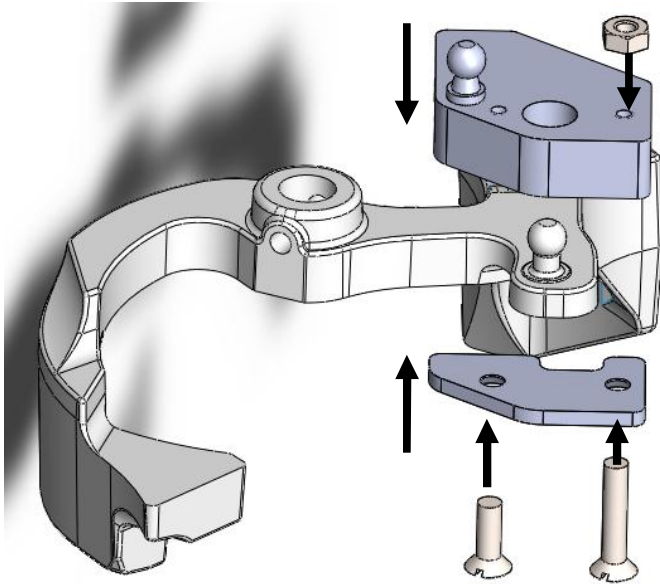

Install the Steeda billet bracket over the factory bracket. Then install the stamping and screws under the bracket. The longer screw goes away from the new ball stud on the Steeda billet bracket.

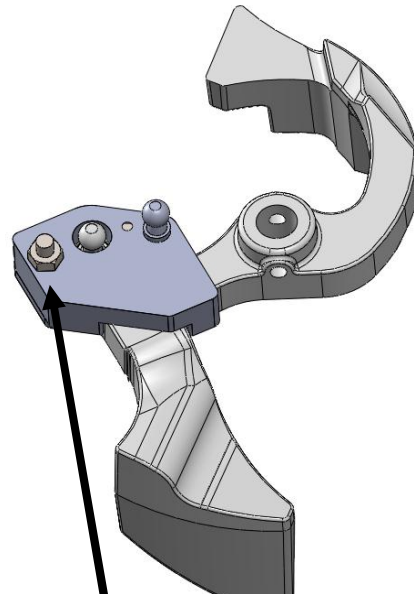

With the bracket in place, install the lock nut over the longer bolt. Snap the factory cable socket onto the new ball stud. Make sure it snaps into place.

9. Install the shifter cable socket over the new ball stud. It must snap into place. See figure 9. Ensure it is securely clipped into place by gently trying to pull it off the ball stud. It should not pull off.
10. Complete installation by reinstalling all of the factory parts in reverse order of removal.
Note: prior to reinstalling all parts, shift the transmission through all gears (with the engine off) to ensure there is no binding or problems with the shifter assembly.
11. You are done. Test drive the car to verify shifter function.

Thank you for choosing Steeda Autosports! We truly appreciate your commitment to U.S manufactured products. If you have any questions or comments please call us at 954-960-0774 or email GoFast@Steeda.com