

g-Bar & g-Link Canted-4-Bar Rear Suspension Conversions for Ford/Mercury and GM Muscle Cars



Mustang g-Link with FAB9™ housing

Camaro g-Link with OEM housing



Canted-4-Bar Suspension Conversions

The g-Bar and g-Link bolt-in, canted-4-bar suspension systems directly replace the OEM leaf springs and shocks for remarkably improved handling and performance. Each can be used with our vehicle-specific bolt-in FAB9™ housing or the vehicle's existing housing. Additional welding is required for installation with all housings other than our bolt-in FAB9™. Chassiswork's second generation g-Bar and g-Link suspension systems represent the current state-of-the-art in canted-4-bar design.

Available for '64-73 Mustangs, '67-70 Cougars, '67-81 Camaros/Firebirds, '68-74 Novas and '62-67 Chevy IIs. The g-Bar system consists of three different combinations of upper and lower link bars with your choice of VariShock coil-over or air-spring shocks. These options create six different variations to better suit your particular performance application. See the following pages for individual photos of each system.



g-Bar & g-Link Street & Performance Systems

g-Bar and its variant, g-Link, dramatically improve ride quality and performance over the stock leaf-spring suspension. The canted-4-bar design is a proven suspension system commonly used in later model American muscle cars of all makes. Four individual arms precisely position the rear axle, better defining the correct suspension travel path. A panhard bar is not required with this style of suspension. This enables spring rates to be easily changed without altering suspension geometry or allowing changes in pinion angle and lateral movement. Lighter spring rates can be used for better ride quality without allowing leaf-spring wrap-up, a common source of wheel hop. Our links are available with premium urethane or, pivot-ball ends to create controlled ride quality that inspires more confident performance driving.

g-Bar and g-Link systems feature VariShock billet-aluminum coil-over shocks (DA pictured) with spring rates (per your vehicle's rear weight) ranging from 110-350 lbs/in. Factory-valved SensiSet (SS) shocks are included with QuickSet 1 (16-settings) single-adjustable and QuickSet 2 (256-setting combinations) double-adjustable shocks available to truly unlock the tuning potential of your suspension.

Camaro g-Bar Air-Spring Suspension with Sliding-Link Anti-Roll Bar



Mustang g-Link Coil-Over Suspension with Splined-End Anti-Roll Bar



Self-Positioning Installation

The g-Bar chassis cradle's self-positioning system utilizes existing factory undercarriage features for precise location. Installation requires no fabrication, with only minimal welding and trimming. Cougar applications require installation of supplied cradle tunnel. Our 3-piece cradle design, consisting of the cradle weld assembly and separate frame rail brackets, allows for variations in OEM chassis dimensions. Once adjusted to correctly fit the chassis, the cradle assembly is then stitch welded to major structural components of the vehicle, such as frame rails and reinforced sections of sheet metal. Multiple attachment points and tubular construction successfully create an effective chassis-stiffening cradle, while providing a stable suspension-mounting crossmember. The cradle weld assembly is powder coated black to prevent rust, and frame rail brackets clear-zinc plated to make coating removal easier prior to stitch welding into the chassis. Welds and exposed metal can be easily painted after installation.



"Self-positioning" system uses existing pinion snubber and top shock mount bolt holes.



Lower links mount at OEM leaf-spring brackets.



g-Bar axle bracket assembly.

The g-Bar cradle provides the chassis attachment points for the upper suspension links and shocks. The upper-suspension-link housing mount is welded directly to the axle tube. A preassembled, fabricated 9" housing (FAB9™) complete with welded bracket assemblies is available to streamline installation and save time. Installation using a factory housing will require our easy-to-use weld fixture to accurately position the brackets. Lower suspension links utilize the factory front leaf-spring bracket and mount to the g-Bar axle bracket. The axle bracket is part of the direct-fit FAB9™ housing, or can be securely u-bolted directly to the existing factory housing leaf-spring pads.



Accurate weld-fixture placement.

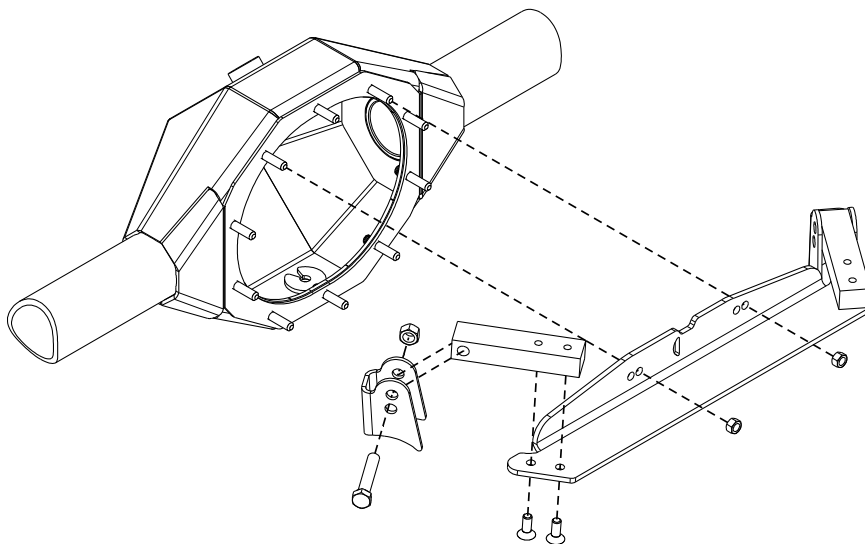

Simple to use upper bracket weld fixture.

Adjustable Suspension Geometry

Upper and lower control arm mounting brackets feature multiple positions to adjust chassis anti-squat and optimize vehicle handling. Both upper bars are length adjustable to set pinion angle and preload. g-Link lower arms are also adjustable for wheelbase variations and precise housing alignment. Some vehicles are worn enough that the wheelbase will not be correct without using a wheelbase adjustable lower link.



4-position FAB9™ lower arm bracket



2-position chassis and housing arm brackets

Multiple Link Bar Styles

Lower Link Bars

There are three lower link styles and two upper link styles. Their proper selection depends on the intended use of your Mustang.

Poly-Bushing Lower Bar

Included in the g-Bar system is the lower fixed-length-tubular link with poly bushings in each end. It is best for vehicles seeing mostly street use because it provides a quiet ride and improved handling.

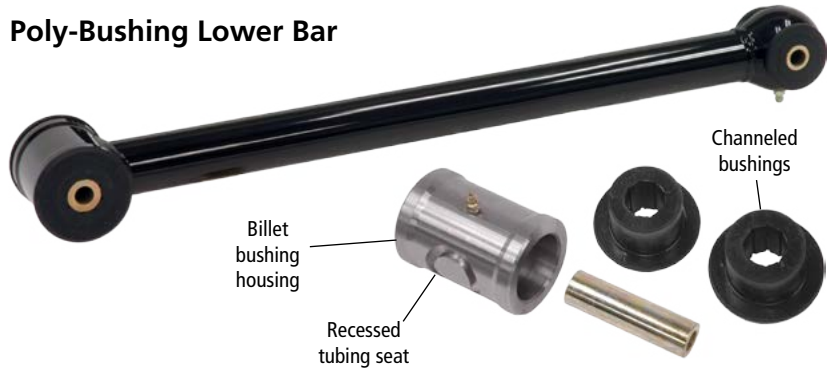

Pivot Ball Lower Link

Included in g-Link system is the lower adjustable-length-tubular link with pivot ball mechanisms in each end. This is our ultimate performance link for use on performance driven street or track applications.



Billet Pivot Ball Lower Link

Included in billet g-Link system is the lower fixed-length billet I-beam link with pivot ball mechanism in each end. The billet link features all radius corners for reduction of stress risers and a pocket area for lower weight. This ultimate link is for those who want to set their g-machine apart from the crowd. It combines the characteristics of our fixed-length link (which is easier install) with the best performance links and, adds a custom built g-machine look. All link bars are externally greasable at each end. Pivot ball mechanism can be rebuilt and tightened to remove play as they wear. Lower link bar fronts attach to the front leaf-spring eye in the chassis.

Billet Pivot Ball Lower Link



Upper Link Bars

Both styles of upper links are constructed of billet alloy steel and clear zinc finished for corrosion resistance. They are length adjustable, and feature a Chassisworks exclusive - massive 7/8"-shank billet alloy steel rod ends.

Poly-Bushing Upper Bar

Poly links use urethane bushings in both ends for a firm but stiffer-than-stock ride. They are included in g-Bar system.

Pivot Ball Upper Link

Pivot ball links are included with g-Link and billet g-Link systems and are used when no-compromise handling is required. The high misalignment and non-compressible nature of these links will guarantee your vehicle goes where you point it.

Poly-Bushing Upper Bar

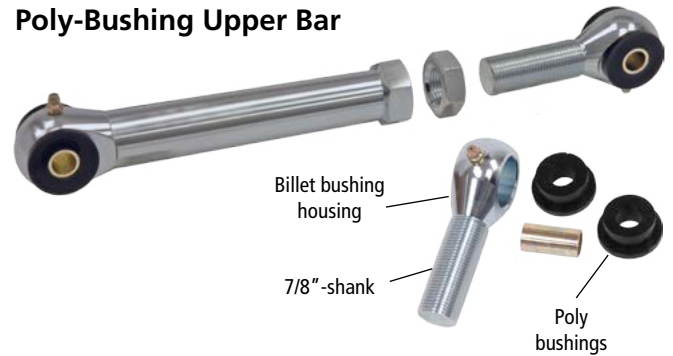

Pivot Ball Upper Link

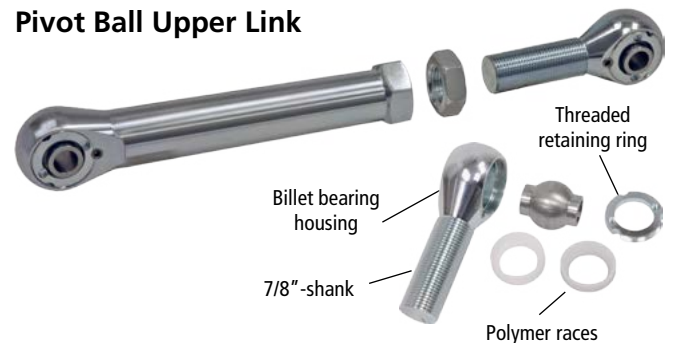

Adjustable shock mounts

Billet aluminum double shear lower shock mounts bolt directly to the back of the lower control arm bracket and provide 4-1/2 inches of ride height adjustments. The upper shock mount has three positions to allow additional ride height and shock angle adjustment. You can adjust the shock angle in at the top to provide increased stability during hard cornering.

Stock rear end housing

System is compatible with Ford 8- or 9-inch, or GM 10- or 12-bolt stock axle housings with at least a 2-13/16" diameter axle tubes. The 1-piece formed upper-suspension-link axle mount is easier to install than 2-piece styles. Upper control arm brackets weld on and lower control arm brackets attach to the housing on the leaf spring pad using included u-bolts.

Exhaust Clearance

The rear section of the factory exhaust is not compatible with g-Bar. Although space is limited, there is room to run a custom built exhaust system over the housing. Easier solutions include turn-downs before the housing or routing the exhaust underneath the housing.



VariShock Coil-Overs for g-Bar Systems

To take full advantage of the outboard mounting position, a complete custom shock absorber was developed by our sister company, VariShock. Installed height, travel, valving range, and mounting configuration are built to our exact specifications, whereas other manufactures are forced compromise with "off-the-shelf" products.

VariShock Development

During five years of intense research and development every shortcoming of conventional performance shocks was successfully corrected. Designed from a clean sheet of paper, VariShocks QuickSet mechanism combines sophisticated shock valving with all-new, American-made components. Never before have so much performance, repeatability and adjustability been offered to classic vehicles.

Adjustable Shock Valving

VariShock's QuickSet, adjustable, design is easy to tune: 16 different settings are attainable simply by rotating the fully accessible, positive click knobs. Knobs are laser-etched with directional arrows and "plus/minus" symbols that clearly indicate which direction achieves the desired adjustment. Adjustments are made in seconds, without removing or unbolting the VariShock. QuickSet 1 shocks use a single knob to simultaneously set bump (compression) and rebound (extension) characteristics. QuickSet 2 double-adjustable shocks are available as an upgrade to enable separate 16-position compression and rebound adjustments.

Revolutionary Adjustment Mechanism

The revolutionary adjustment mechanism is smaller than any previous design, allowing our billet-aluminum body to be both shorter and lighter. You get more clearance around the eyes, plus greater travel within any shock length. The shocks use "Deflective Disk Valving" in the pistons to eliminate spring fatigue. Piston rods are made from 5/8" centerless ground hard chrome steel for wear resistance and long service life. VariShock models are even "rebuildable" in the event they get bent or damaged. Custom valving is also available.

Premium Urethane Ends

The urethane end has up to 350% more urethane material than other brands, for superior load distribution, yet no less clearance around the eye. We also chose a premium urethane that has a much higher load capacity (for improved life) than the poly bushings from other manufacturers. Urethane ends are 1-1/4" wide and accept 1/2" bolts.

Locking Lower Spring Seat

A new-design, one-piece lower spring seat does not require a lock nut; it's locked in place by two ball locks that press into the grooves on the reservoir body and easily unlock with an Allen wrench for adjustment.

Shock Specifications

Part Number	Valves	Ride Height	Length (Compressed)	Length (Extended)	Shock Travel
VAS 110XX-515	Factory	13.53"	10.95"	16.10"	5.15"
VAS 111XX-515	Single	13.53"	10.95"	16.10"	5.15"
VAS 112XX-515	Double	13.53"	10.95"	16.10"	5.15"



High-Travel VariSprings

The new VariSpring line of springs was designed to complement the VariShock family. Once again, we used higher technology to resolve application limitations. These springs are manufactured using a new, ultra-high-tensile wire, which is stronger than the chrome silicon wire used by other manufacturers. This allows the springs to “set solid.” The springs can compress until the coils touch without damaging the spring or causing it to take a set, which ultimately changes the ride height. Since this wire can flex more than conventional wire, these springs have greater travel than our competitors’ springs of the same rate. These springs will allow your shocks to travel their full range of motion without going solid. This gives you greater traction and control at full bump, plus additional suspension travel for tuning. If you are ready to take advantage of higher technology with greater travel, lighter, stronger springs, then step up to VariSprings. VariSprings have a silver-powder-coat finish.



Spring Rate Selection

Spring rate affects ride quality, ride height, roll rate, and performance handling characteristics. Differences in vehicles such as aluminum engine components, vehicle weight distribution, fiberglass body parts, chassis stiffening as well as wheel-size and offset and the specific performance application, should be taken into consideration. Additional tuning springs are available at a discount when purchased with a system. A good spring-rate baseline for Mustangs with rear g-Bar or g-Link, and with a small-block engine seeing regular street use would be 175-200 lbs/in., depending upon desired ride quality. A good baseline is for every 100-lb. change in rear vehicle weight, the spring rate needs to change by 25 lb/in.

Rear Weight (lbs)	Part Number	Rate (lbs)	Travel (in)
925-1000	VAS 21-12110	110	7.91
1000-1100	VAS 21-12130	130	8.43
1100-1225	VAS 21-12150	150	7.61
1225-1350	VAS 21-12175	175	7.60
1350-1575	VAS 21-12200	200	7.45
1575-1825	VAS 21-12250	250	7.00
1825-2075	VAS 21-12300	300	7.07
2075-2350	VAS 21-12350	350	7.00

VariShock Accessories

Spanner Wrench

Also available is an exclusive spanner wrench, incorporating four tangs, which will not slip off the lower spring seat because it engages the seat in four places (not one, like common spanners).



899-012-201

Spring-Seat Thrust Bearings

Thrust bearings are used at the lower spring seat to reduce friction when adjusting ride height. New stainless “cap-style” seats, a VariShock exclusive, enclose the thrust bearing to keep dirt out.



VAS 513-100

Coil-Over Spring Compressor

The VariShock coil-over-spring compressor greatly eases lower-spring-collar adjustment on high-preload or high-rate applications. Heavy-duty plates at each end fit 2-1/2” inside-diameter coil springs of 130 lb., rate or greater, with a maximum spring height of 14”.



VAS 200

Part Number	Description
VAS 512-1-2	1”-extended top shock eye, COM8 bearing (pair)
VAS 512-2-2	1”-extended top shock eye, poly bushing (pair)
VAS 513-100	Spring seat thrust bearing set (pair)
899-012-201	VariShock spanner wrench, zinc plated steel
VAS 200	Coil-over spring compressor for 2-1/2” springs

VariShock Coil-Over Equipped g-Bar Systems



The g-Bar and g-Link suspension systems come equipped with VariShock coil-over shocks and high-travel VariSprings. A traditional coil-over configuration features the ability to corner-balance the vehicle by varying spring preload, and offers predictable suspension tuning results. VariShock coil-over equipped, g-Bar and g-Link systems are available for use with direct-fit FAB9™ or

factory rearend housings. Options include: poly-bushing, pivot-ball, or billet pivot-ball arms; sliding-link or spline-end anti-roll bars; and single- or double-adjustable VariShocks.

Part Number	Descriptions
58XX-XXX	VariShock coil-over equipped g-Bar/g-Link
OPTION	FAB9™ direct-fit rearend housing
OPTION	Anti-roll bar, sliding link style, chassis mounted
OPTION	Anti-roll bar, spline end style, housing mounted
OPTION	SS, QS1, QS2, or QR4 VariShocks



Shown with g-Link pivot-ball links, spline-end anti-roll bar, and direct-fit FAB9™ housing.

g-Bar Poly Eye

Best suited for street-performance applications, the polyurethane bushed, g-Bar system features fixed-length, tubular-steel lower links matched with adjustable-length, billet-steel upper links. Greasable urethane bushings ensure reduced vibration and quiet operation.

Ford Applications	
5800-C10	1967-70 Cougar
5800-M10	1964-66 Mustang
5800-M20	1967-70 Mustang
5800-M30	1971-73 Mustang

GM Applications	
5800-F10	1967-69 Camaro/Firebird
5800-F21	1970-77 Camaro/Firebird
5800-F22	1978-81 Camaro/Firebird
5800-X10	1962-67 Chevy II / Nova
5800-X20	1968-74 Nova

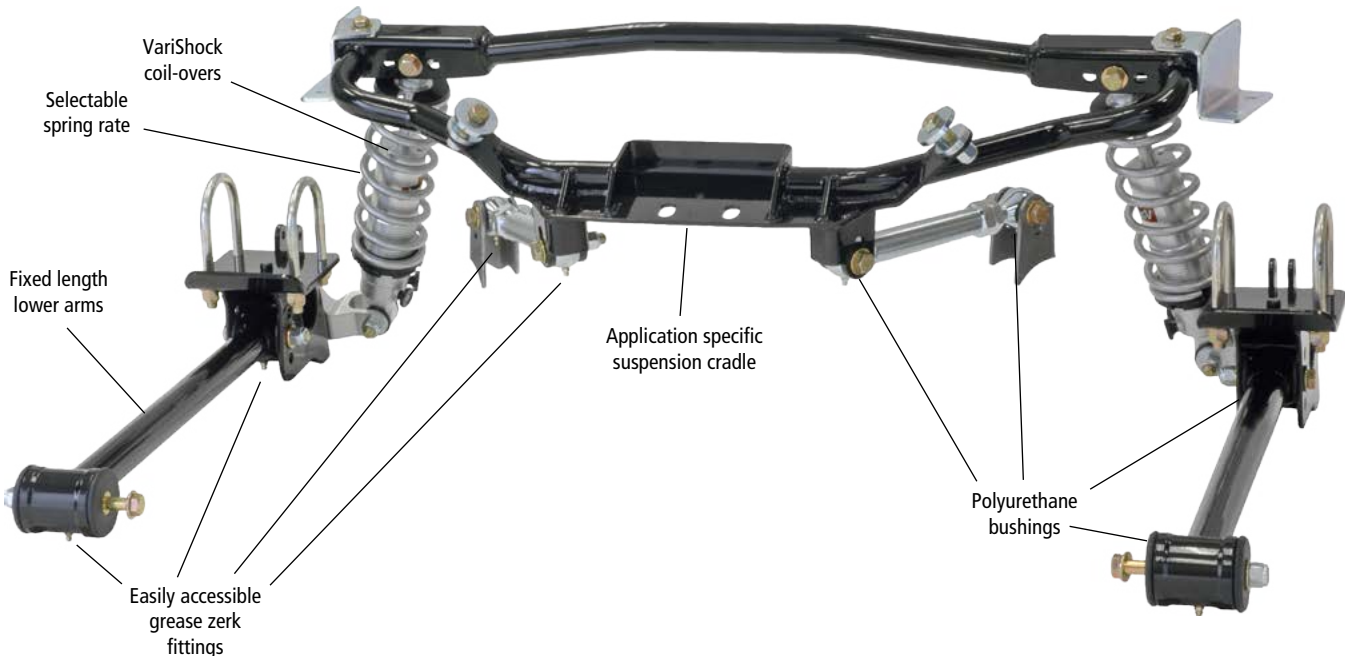

g-Link Pivot Ball

Best suited for high-performance applications, the g-Link system features a deflection-free pivot-ball mechanism at each link's end for razor sharp handling. Tubular-steel lower and billet-steel upper links are adjustable in length for exact housing placement.

Ford Applications	
5804-C10	1967-70 Cougar
5804-M10	1964-66 Mustang
5804-M20	1967-70 Mustang
5804-M30	1971-73 Mustang

GM Applications	
5804-F10	1967-69 Camaro/Firebird
5804-F21	1970-77 Camaro/Firebird
5804-F22	1978-81 Camaro/Firebird
5804-X10	1962-67 Chevy II / Nova
5804-X20	1968-74 Nova

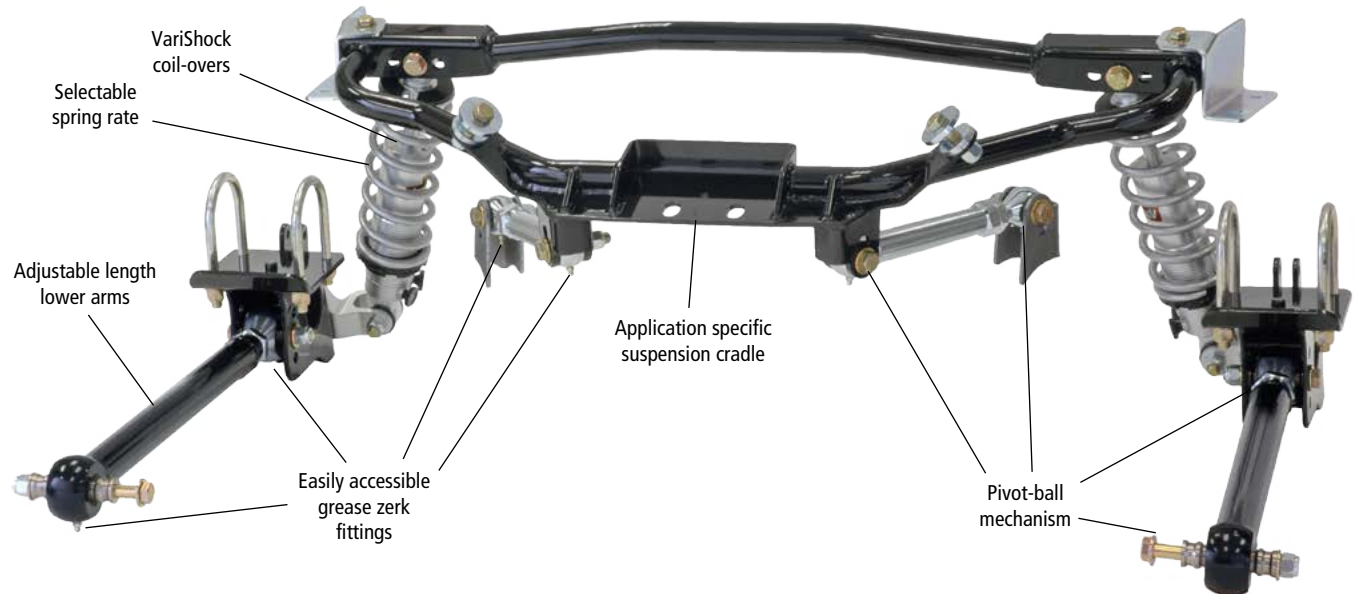

g-Link Billet Pivot Ball

Billet g-Link system has the attention grasping look of CNC-machined aluminum components with the performance to back it up. The system features deflection-free pivot-ball mechanisms at each link's end for razor sharp handling. Billet g-Link features fixed-length, aluminum lower links matched with adjustable-length, steel upper links.

Ford Applications	
5813-C10	1967-70 Cougar
5813-M10	1964-66 Mustang
5813-M20	1967-70 Mustang
5813-M30	1971-73 Mustang

GM Applications	
5813-F10	1967-69 Camaro/Firebird
5813-F21	1970-77 Camaro/Firebird
5813-F22	1978-81 Camaro/Firebird
5813-X10	1962-67 Chevy II / Nova
5813-X20	1968-74 Nova

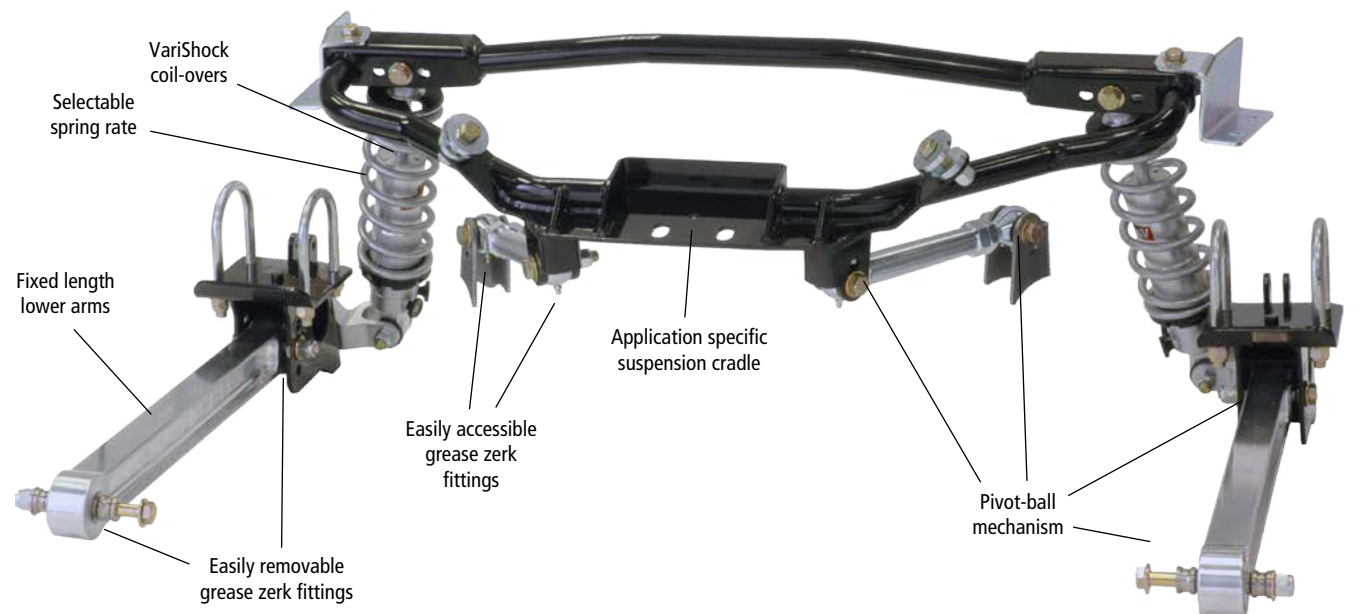

VariShock Air-Spring g-Bar/g-Link Systems



Each style of g-Bar and g-Link rear suspension system can be packaged with VariShock air-spring shocks, in either single- or double-adjustable versions. Without the additional complication of separate shocks and air bags, VariShock air-spring shocks enable instant ride-height and ride-quality adjustment in a simple integrated design. When fully

deflated, the vehicle rests 5-6" inches below stock ride height and can be raised to driving height at a button. Compressor systems (available separately) required for operation.

The air springs integrate seamlessly with the billet-aluminum shock in essentially the same position as a traditional coil spring, concentric to the length of the shock. This allows air-suspension systems to benefit from the same highly-adjustable QuickSet valve mechanism found on VariShock coil-overs and struts, but revalved to meet the special requirements of an air spring configuration. This combination of technologies gives you complete ride control as well as adjustable ground clearance.

Part Number	Descriptions
58XX-XXX	VariShock air-spring equipped g-Bar/g-Link
OPTION	FAB9™ direct-fit rearend housing
OPTION	Anti-roll bar, sliding link style, chassis mounted
OPTION	Anti-roll bar, spline end style, housing mounted
OPTION	QuickSet 2, double-adjustable shock upgrade

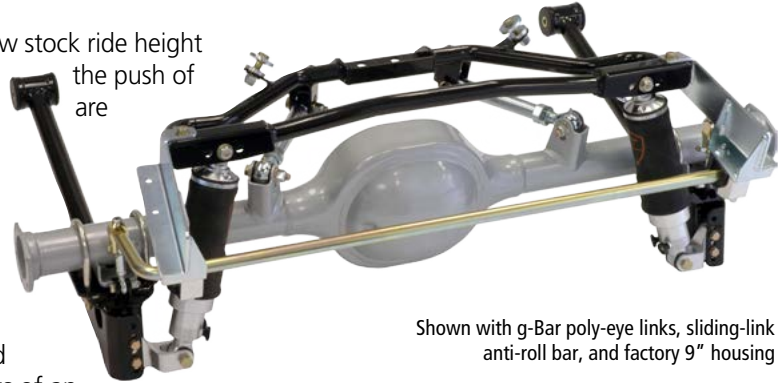

Shown with g-Bar poly-eye links, sliding-link anti-roll bar, and factory 9" housing

Air Management Systems and Components

To enable complete operation of your VariShock air-spring suspension, we offer a variety of electronic control and compressor systems, as well as individual components from the industry's leading manufacturers.

Contact our technical sales staff for information.



Air g-Bar Poly Eye

5801-C10	1967-70 Cougar
5801-F1X	1967-81 Camaro/Firebird
5801-M10	1964-66 Mustang
5801-M20	1967-70 Mustang
5801-M30	1971-73 Mustang
5801-X10	1962-67 Chevy II / Nova
5801-X20	1968-74 Nova

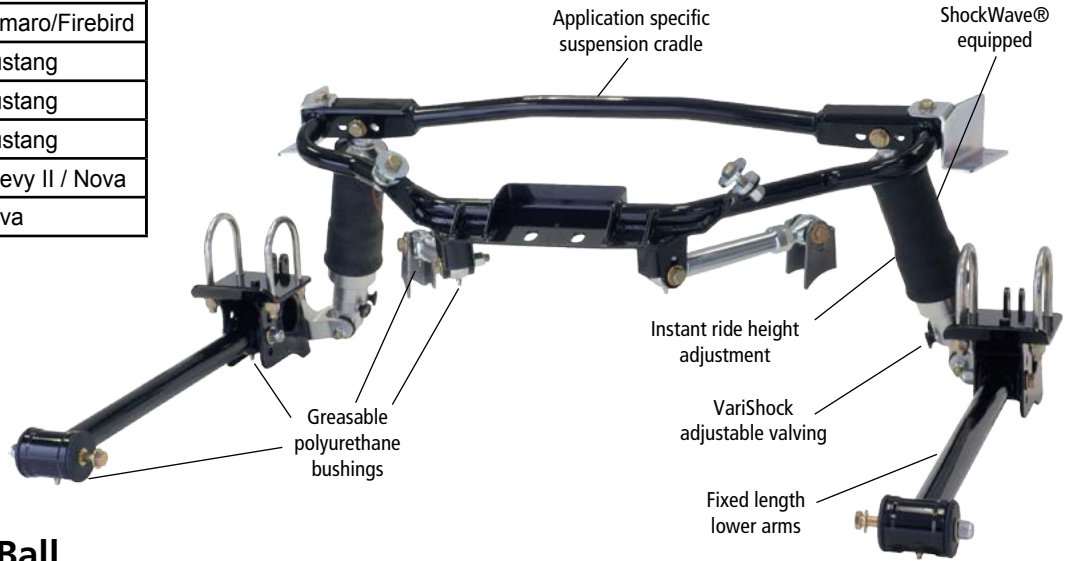

Air g-Link Pivot Ball

5805-C10	1967-70 Cougar
5805-F1X	1967-81 Camaro/Firebird
5805-M10	1964-66 Mustang
5805-M20	1967-70 Mustang
5805-M30	1971-73 Mustang
5805-X10	1962-67 Chevy II / Nova
5854-X10	1962-67 Chevy II / Nova (mini-tubbed)
5805-X20	1968-74 Nova

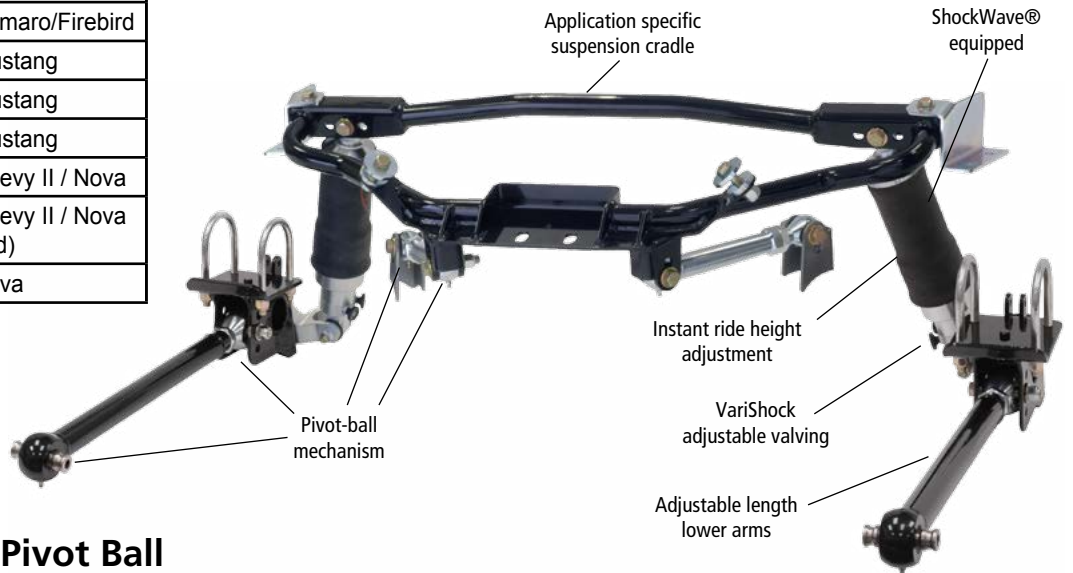

Air Billet g-Link Pivot Ball

5814-C10	1967-70 Cougar
5814-F1X	1967-81 Camaro/Firebird
5814-M10	1964-66 Mustang
5814-M20	1967-70 Mustang
5814-M30	1971-73 Mustang
5814-X10	1962-67 Chevy II / Nova
5854-X10	1962-67 Chevy II / Nova (mini-tubbed)
5814-X20	1968-74 Nova

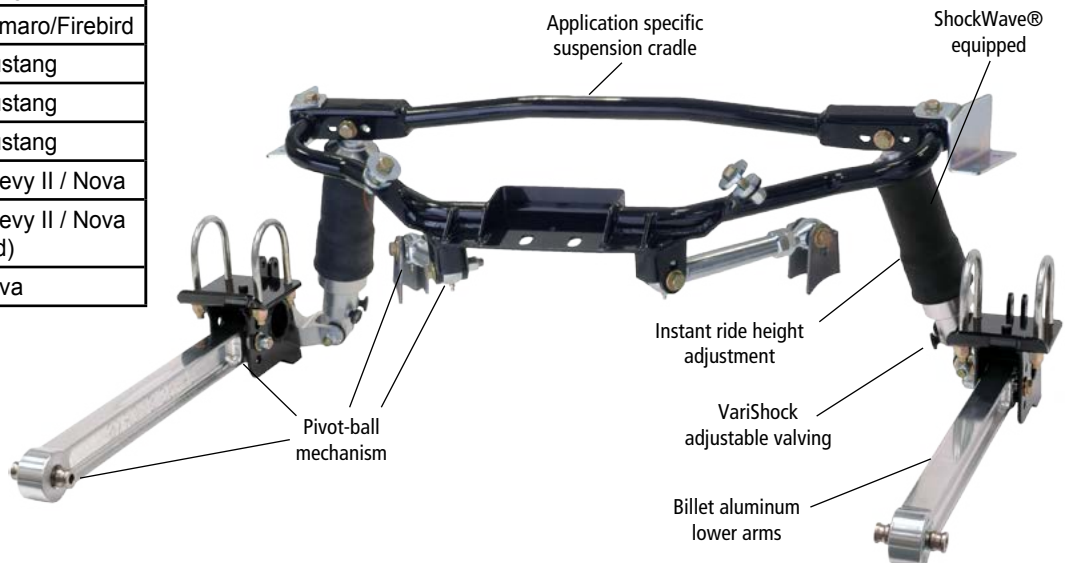

Rear Anti-Roll Bars

Chassisworks developed two styles of rear anti-roll bars for use with our g-Bar/g-Link canted-rear-suspension systems. The first, a solid, adjustable rate, bar mounted to the frame rearward of the rearend housing. The second, a splined-end, tubular bar mounted to the rearend housing, below the axle.

Do I really need a rear anti-roll bar?

In an effort to correct excessive body roll on early muscle cars, the common approach is to add a large front anti-roll bar. This may initially appear to correct the issue, but with the unintended result of increased understeer on an already nose-heavy vehicle. To regain vehicle cornering balance a rear anti-roll bar may be needed. For mild street-performance vehicles a rear anti-roll bar will provide a noticeable improvement to the "tightness" of the handling. However, on high-performance vehicles operating at or near the vehicle's traction limits, careful testing is required. First, to determine need of a rear bar, and then to properly setup the vehicle to optimize cornering balance. Testing your vehicle with different springs, shock settings and anti-roll bars will definitely yield increased handling. If it is a specific look you are after then that's a good enough reason to put one on your car. Nothing is better looking than our billet g-Bar, with splined-end anti-roll bar with billet aluminum arms.

Sliding-Link Adjustable Anti-Roll Bar

The sliding-link anti-roll bar system features a 5/8" -diameter, solid bar mounted to the same frame adapter brackets as the g-Bar suspension cradle for a complete bolt-on installation. Billet-aluminum bushing housings securely hold the bar and feature a grease-zerk fitting, and black-polyurethane bushings with internal grease passages. Our unique sliding-link mechanism, utilizes three distinct indents at each end of the anti-roll-bar lever to create six incremental adjustments. The CNC-machined clevis is locked into each detent by a set screw and jam nut, preventing unintended sliding or twisting of the assembly. Links consist of 3/8" rod-ends, allowing the anti-roll bar to be precisely set to a neutral, non-preload condition, by adjusting the assembly length. The sliding-link anti-roll bar system can be used on the entire family of g-Bar suspensions.

Note: Required g-Bar frame-adapter bracket with integrated anti-roll bar mounting flange is packaged with g-Bar system and must be selected at time of g-Bar purchase.

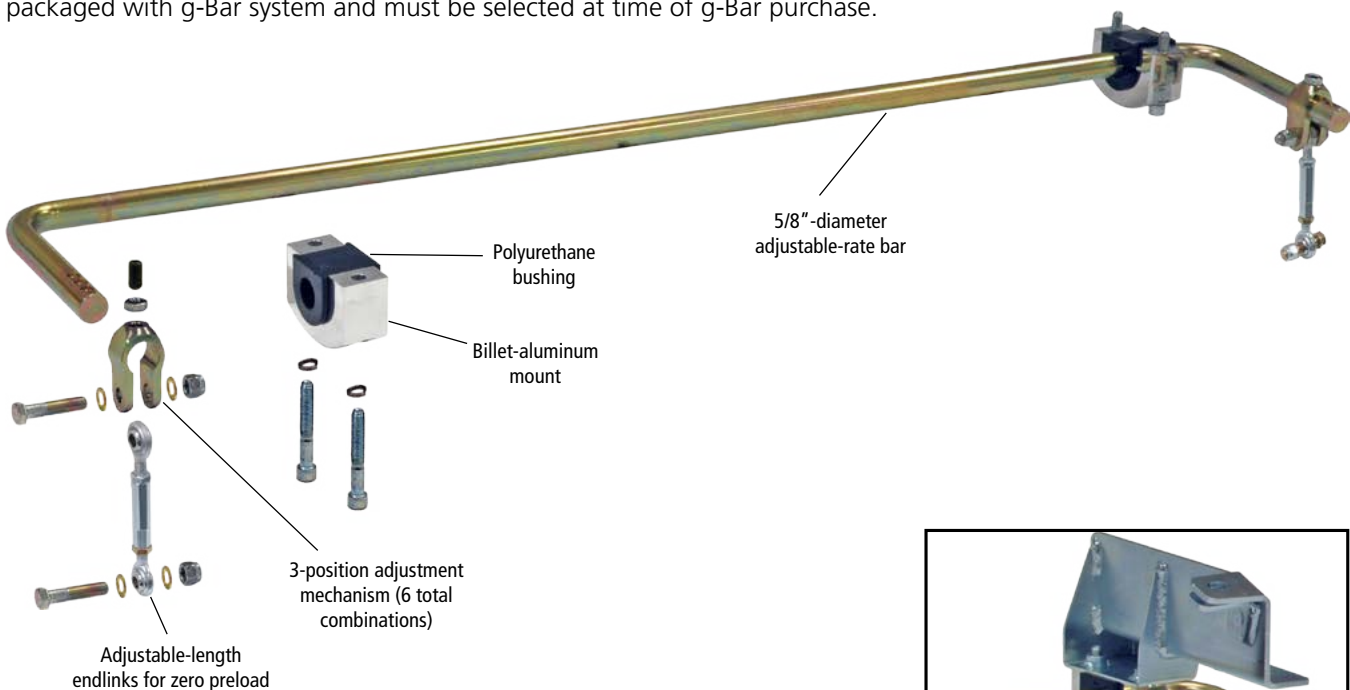

Part Number	Description
5812-F10	1967-69 Camaro/Firebird
5812-F20	1970-81 Camaro/Firebird
5812-M10	1964-73 Mustang, 1967-70 Cougar
5812-X10	1962-67 Chevy II / Nova
5812-X20	1968-74 Nova

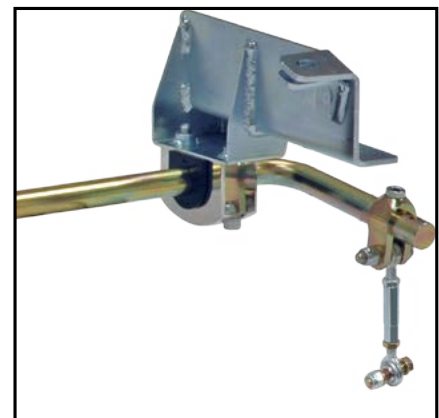

Splined-End Tubular Anti-Roll Bar

Our splined-end anti-roll bar system features a 3/4"-diameter, bent-tube design, that mounts below the rearend-housing. The bar adequately clears FAB9™ and OEM center sections, without decreasing ground clearance. An adjustable, billet-pivot-socket mechanism threads into the g-Bar lower axle-bracket sleeve, and allows the bar to rotate smoothly in a play-free joint. Billet-aluminum arms extend forward, and are connected to the chassis through links consisting of adjustable-length, 3/8" rod-end assemblies. This allows the anti-roll bar to be precisely set in a neutral, non-preloaded state. Double-shear, steel mounts are welded along the stronger, outside corner and across the bottom of the stock frame rail. The combination of Chassisworks' exclusive pivot mechanism, splined bar ends, spherical-bearing links, and rigid chassis attachment eliminates delayed resistance in the anti-roll bar system, common with rubber-, or urethane-mounted systems. The splined-end anti-roll bar system can be used on the entire family of g-Bar suspensions.

Note: Required g-Bar axle bracket with integrated anti-roll-bar socket boss is packaged with g-Bar system and must be selected at time of g-Bar purchase.

g-Bar and g-Link (Standard)

5806-F10	1967-69 Camaro/Firebird, 1968-74 Nova
5806-F20	1970-81 Camaro/Firebird
5806-M10	1964-73 Mustang, 1967-70 Cougar
5806-X10	1962-67 Chevy II / Nova

g-Bar and g-Link (Mini-Tubbed)

5821-F10	1967-69 Camaro/Firebird, 1968-74 Nova
5821-F20	1970-81 Camaro/Firebird
5821-X10	1962-67 Chevy II / Nova

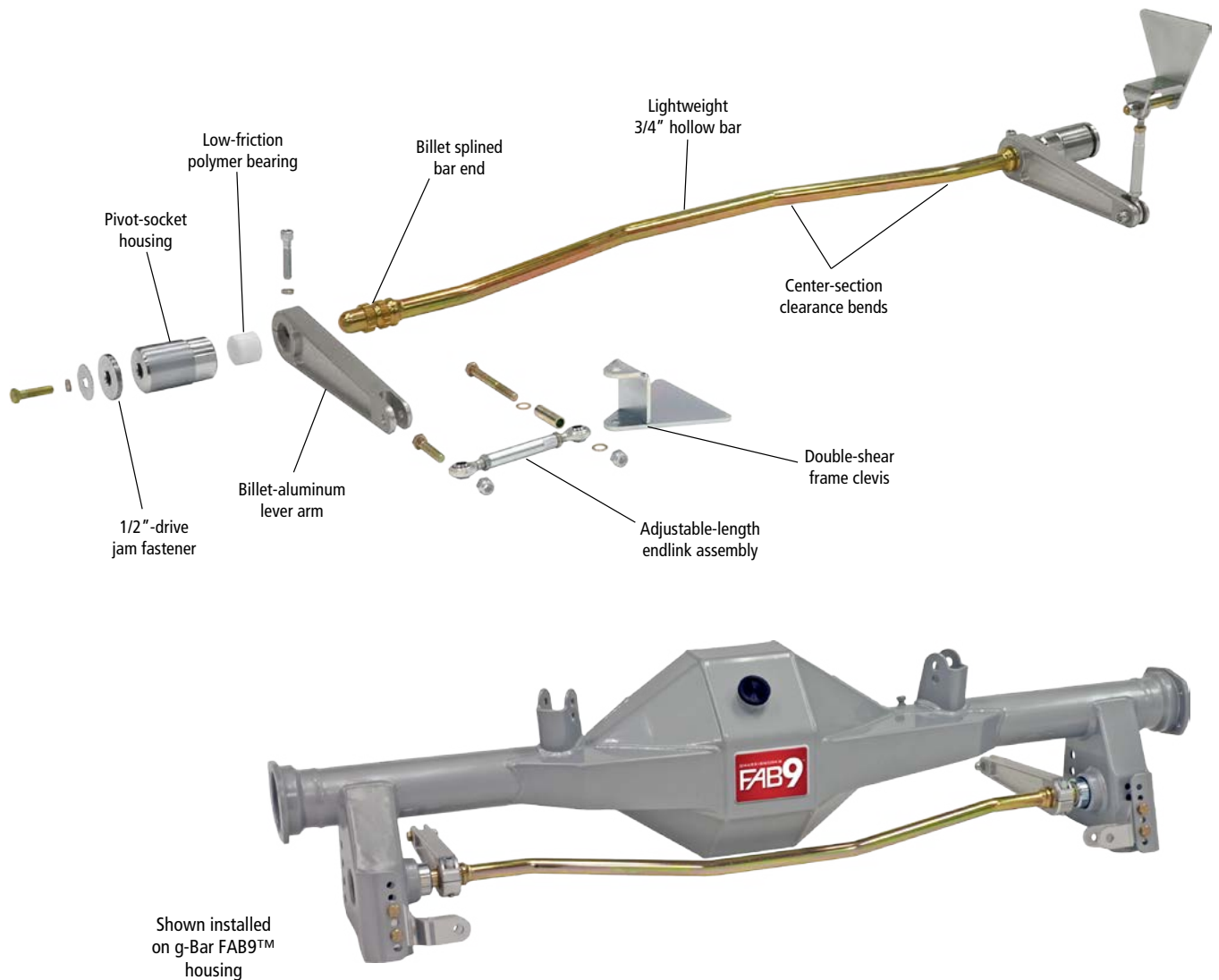

Direct-Fit FAB9™ Rearend Housings

FAB9™ Construction

Finite element analysis software was used to create a fabricated 9" (FAB9™) center section stronger yet lighter than its OEM counterpart. Angular panels, internal gussets, and a heavy wall front face are assembled by robotic spray-arc welder to ensure every housing is built to exacting standards. Axle tubes are 3" in diameter and welded along the internal tube gusset as well as the tapered edge of the center section. It is this enclosed internal chamber at each end of the center section that gives the entire assembly superior strength over OEM and competitor's designs. The housing can be further strengthened by adding an optional folded back brace. FAB9™ back braces are exact fit boxed structures spanning from the outer edge of the back panel to the inside edge of the axle mounts. The tapered design is broad closest to the center section for maximum support and narrows towards the housing ends for lighter weight.

Complete Hardware Kit

Each FAB9™ housing comes equipped with an easily accessible fill hole, drain, and all necessary hardware. The fill hole is purposely oversized and strategically placed to allow visual inspection of the ring gear without draining fluid or disrupting gaskets or seals. A black anodized, billet aluminum cap with o-ring seal prevents any unwanted fluid seepage. A specially slotted drain insert, welded to the floor of the center section, allows complete drainage of fluid and increases drain plug thread engagement. The magnetic drain plug with reusable copper gasket captures metal particles from being suspended in the fluid, reducing the rate of wear on gears and seals. To relieve internal pressure, housings are fitted with an axle vent located along the top of the axle tube. Equalized pressure improves the effectiveness of all seals and gaskets for trouble free extended use. If an external fluid catch can is required, axle vents can be easily removed using the 7/16" hex and replaced with an appropriate 1/8" NPT fitting. Third-member mounting hardware consists of high-strength 12-point studs, hardened SAE flat washers, and nylon insert lock nuts.



Robotic spray-arc welded center section with internal tube gussets



Housing hardware includes: billet cap, magnetic drain plug, 12-point studs, hardened washers, locknuts, and vent (not shown).



Fill/inspection hole with billet-aluminum, o-ring sealed, cap



Screw-in axle vent eliminates seal damage from pressure build up.



Engineered to accept all 9", Ford-style differentials, each FAB9™ includes a fully-welded center section with internal gussets, 3" axle tubes, and Ford big-bearing, late-model Torino, housing ends. All housings are manufactured in-house utilizing our state-of-the-art robotic spray-arc welder. Weld penetration, and quality are absolutely outstanding, guaranteeing consistent, reliable performance. Center sections are fully CNC-machined after welding to provide an excellent third-member-seal surface and extremely tight tolerances on the remaining housing features. Optionally, a folded back brace assembly can be factory welded to your FAB9™ housing, substantially strengthening the housing without adding significant weight. Standard housings are constructed from mild steel, but can be upgraded to 4130 chromemoly; recommended for vehicles weighing over 3500 lbs., and/or developing 650-plus horsepower. Housing hardware includes: billet-aluminum, o-ringed filler/inspection cap; axle-tube vent; magnetic drain plug; and alloy-steel, 12-point, mounting studs with locknuts.



g-Bar Direct-Fit FAB9™ Housings

The Chassisworks g-Bar FAB9™ offers exceptional performance, reliability, and adjustability in a bolt-on, factory-welded housing, complete with all suspension brackets. Housings are engineered for proper clearance using either VariShock coil-overs or air suspension; with or without a back brace. Anti-roll-bar bracket options include chassis-mounted (sliding-link bar), axle-housing mounted (splined-end bar), or no anti-roll-bar brackets installed.

Narrowed Housing Widths

Housings can be built to standard widths for OEM wheel offsets or narrowed to accommodate wider tire and wheel combinations. Complete correct length axle packages and third members are also available. Ask our sales representatives for details.

Applications and Dimensions

Part Number	Description	Stock Width	Minimum
84F10-XXX	Camaro '67-69, Nova '68-74	60"	54-3/4"
84F20-XXX	Camaro '70-81	61"	55-3/4"
84M10-XXX	Mustang '64-66	57-1/4"	55-1/4"
84M20-XXX ¹	Mustang / Cougar '67-70	59-1/4"	57-1/4"
84M30-XXX ¹	Mustang '71-73	60-1/4"	59-1/4"
84X10-XXX	Chevy II / Nova '62-67	58"	53"
Notes:	All housings are narrowed in 1/4" increments		
	1 - '64-66 Mustang housing can be substituted for widths less than 57-1/4"		

FAB9™ Housing Styles

Part Number	Description
84XXX-601 ¹	Mild steel, chassis mount ARB ²
84XXX-611 ¹	4130, chassis mount ARB ²
84XXX-701 ¹	Mild steel, housing mount ARB ³
84XXX-711 ¹	4130, housing mount ARB ³
84XXX-801 ¹	Mild steel, chassis mount ARB ² , mini-tubbed
84XXX-811 ¹	4130, chassis mount ARB ² , mini-tubbed
OPTIONS	Folded back brace, mild steel, factory installed
	Folded back brace, 4130, factory installed
Notes:	1 - Also available with small-GM housing ends
	2 - Chassis mount - Sliding-link adjustable anti-roll bar (5812-XXX)
	3 - Housing mount - Splined-end tubular anti-roll bar (5806-XXX or 5821-XXX)

Leaf-Spring Direct-Fit FAB9™ Housings

Direct-fit FAB9™ fabricated housings are available for most models of leaf-spring equipped Camaros, Comets, Cougars, Falcons, Firebirds, and Mustangs. Heavy-duty, leaf-spring pads are clocked for correct pinion angle and perfect alignment with factory leaf-spring mounts. Late-big-Ford housing ends are standard on all bolt-in FAB9s. GM FAB9s can also be ordered with small-GM housing ends.



U-bolt Set

Chassisworks' U-bolts are manufactured from larger, 1/2"-diameter, alloy steel instead of stock 7/16" material. Gold irradiated for durability and formed to fit 3"-diameter axle tubes. These u-bolts will fit with 4- through 5-leaf springs and axle housings, with 2-13/16" through 3"-diameter axle tubes. Included are hardened alloy steel washers and Grade 8 nylon-insert locknuts. Recommended to use LSP-01 or LSP-02 as the stock leaf-spring plates will not accept these larger diameter u-bolts.

Part Number	Description
TCP LSP-03	U-bolt set, 1/2 x 6-1/2" for 3" axle tubes

Model	Year	Mild Steel	4130
Camaro	1967-1969	84F10-101 ¹	84F10-111 ¹
	1970-1981	84F20-101 ¹	84F20-111 ¹
Comet	1964-1965	84M10-101	84M10-111
Cougar	1967-1970	84M20-101	84M20-111
	1971-1973	84M30-101 ²	84M30-111 ²
Falcon	1964-1965	84M10-101	84M10-111
Firebird	1967-1969	84F10-101 ¹	84F10-111 ¹
Mustang	1964-1966	84M10-101	84M10-111
	1967-1970	84M20-101	84M20-111
	1971-1973	84M30-101 ²	84M30-111 ²
Nova	1962-1967	84X10-101	84X10-111
	1968-1974	84F10-101	84F10-111
Ranchero	1964-1965	84M10-101	84M10-111
Options (installed)			
	Folded back brace		
	Torque-arm brackets		
Notes:		1 - Also available with small-GM ends	



Axle Packages and Third Members

Chassisworks is proud to offer high quality axle packages and completely assembled Ford 9" third members from the performance industry leader, Strange Engineering. Packages are available to cover nearly any performance application including street, strip or track use. Contact our expert sales staff for additional information.



S-Series
(Nodular Iron)



Pro-Iron
(Nodular Iron)



HD Pro
Aluminum



All prices subject to change. Current pricing available at www.cachassisworks.com.



Chris Alston's Chassisworks, Inc.
8661 Younger Creek Drive
Sacramento, CA 95828

Order: 800-722-2269
Tech: 916-388-0288
Fax: 916-388-0295

sales@cachassisworks.com
www.cachassisworks.com