

K&N TYPHOON INTAKE SYSTEMS



INSTALLATION INSTRUCTIONS

69-3518
FORD
2013 Focus ST
L4-2.0L Turbo

TOOLS NEEDED:

- Flat blade screw driver
- Ratchet
- Extension
- 8mm socket
- 10mm socket
- 3mm allen key
- 4mm allen key
- 10mm wrench

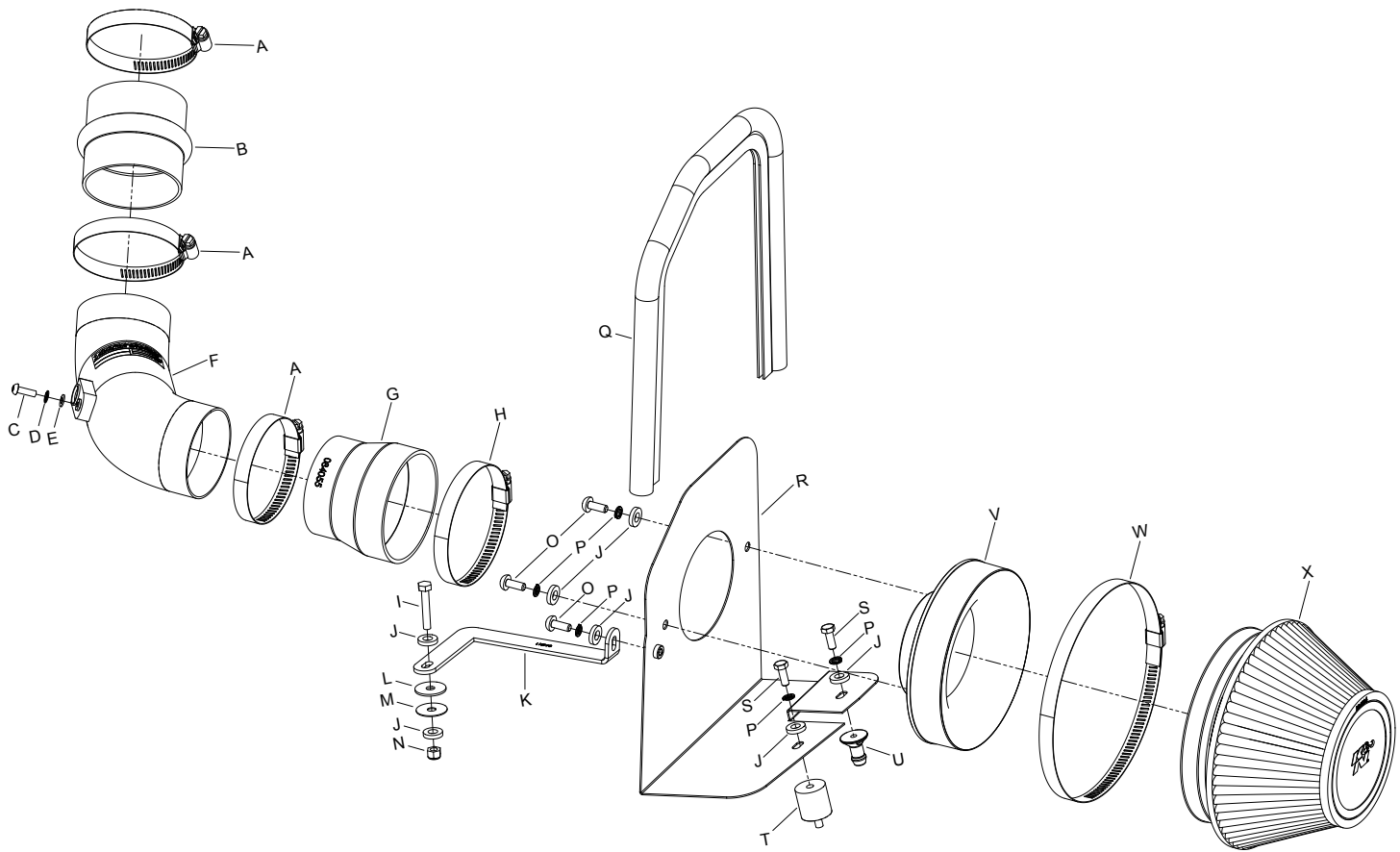

PARTS LIST:

Description	Qty.	Part #	Description	Qty.	Part #	Description	Qty.	Part #
A Hose Clamp #48	3	08601	I Bolt; Hex M6-1 X 35MM	1	1-2002	Q Edge Trim (26")	1	102488
B Hose; 3"ID X 3"L Hump	1	08696	J Washer, 1/4"ID X 5/8" OD-SAE	7	08275	R Heat Shield	1	073148
C Bolt; M5-0.8 X 20MM, SS	1	22208	K Bracket; "Z", 69-3518, STL	1	064311	S Bolt; 6MM-1.00 X 16MM, SS	2	07812
D Washer; 5MM Internal Start Cut	1	07724	L Washer; 1"D X 1/4 Hole Fender	1	08160	T Stud; Rubber Mount, M6 X 1	1	02033
E Washer; 5MM Flat, SS	1	08212	M Washer; 1" X .300 X .100 Rubber	1	21685	U Mount, Plastic Airbox	1	8-186
F Intake Tube	1	27601TS	N Nut; 6MM Nylock, Hexhead,SS	1	07512	V Adapter; Universal, 6" Filter 3.5"	1	21512-1
G Hose; 3-1/2" To 3"ID X 3"L TPRD	1	084055	O Bolt; M6 X 1.00 X 16MM, SS	3	07730	W Hose Clamp #104	1	08697
H Hose Clamp #56	1	08620	P Washer; M6 Split Lock Zinc	5	1-3025	X Air Filter	1	RU-4600

NOTE: FAILURE TO FOLLOW INSTALLATION INSTRUCTIONS AND NOT USING THE PROVIDED HARDWARE MAY DAMAGE THE INTAKE TUBE, THROTTLE BODY AND ENGINE.

TO START:

1. Turn off the ignition and disconnect the negative battery cable.
NOTE: Disconnecting the negative battery cable erases pre-programmed electronic memories. Write down all memory settings before disconnecting the negative battery cable. Some radios will require an anti-theft code to be entered after the battery is reconnected. The anti-theft code is typically supplied with your owner's manual. In the event your vehicles anti-theft code cannot be recovered, contact an authorized dealership to obtain your vehicles anti-theft code.



2. Disconnect the pressure sensor electrical connection.



3. Disconnect the fresh air inlet boot.

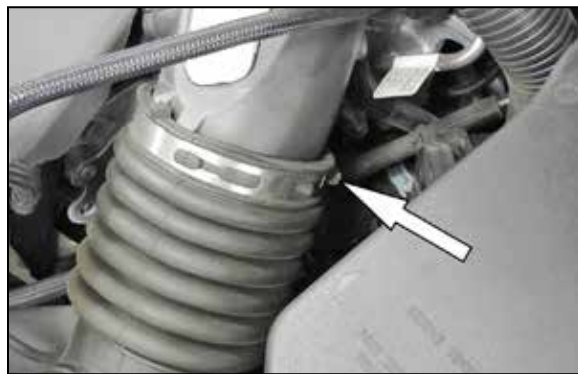

4. Loosen the hose clamp securing the intake hose to the plenum.



5. Remove the air box from the engine compartment.
NOTE: K&N Engineering, Inc., recommends that customers do not discard factory air intake.



6. Remove the fresh air duct from the core support as shown.



7. Install the provided rubber mounted stud into the inner fender as shown.

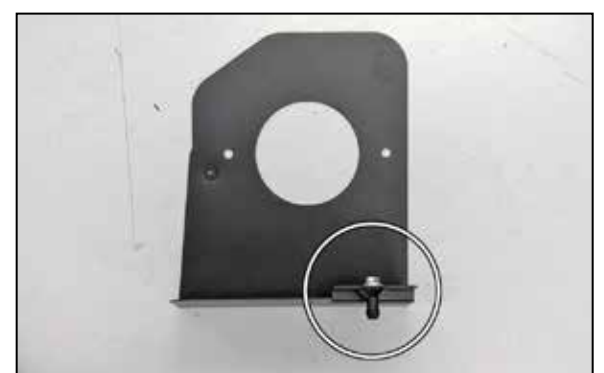

8. Install the provided mounting post onto the heat shield as shown using the provided hardware.

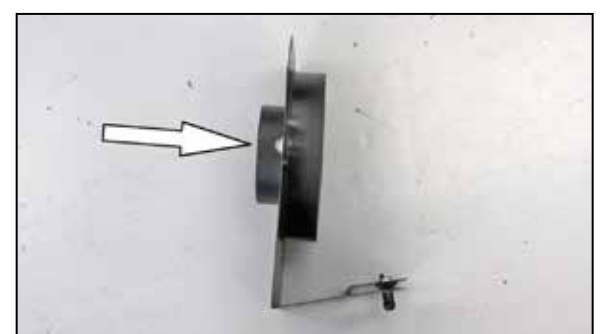

9. Install the filter adapter into the heat shield and secure with the provided hardware.

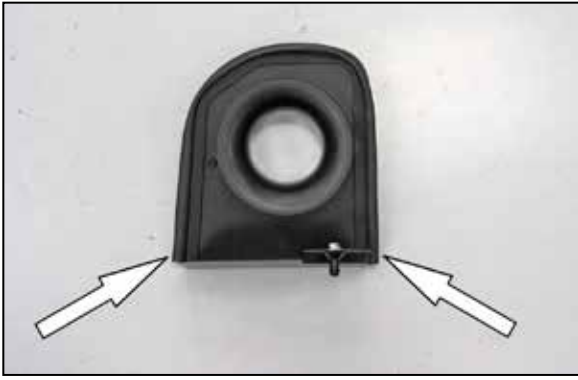

10. Install the provided edge trim onto the heat shield as shown.

NOTE: Some trimming of the edge trim will be necessary.



11. Install the heat shield assembly into the engine compartment and secure it to the rubber mounted stud with the provided hardware.



12. Install the K&N® air filter onto the filter adapter and secure with the provided hose clamp.



13. Install the heat shield mounting bracket (064311) onto the heat shield and core support with the provided hardware.



14. Install the coupling hose #08696 onto the plenum and secure with the hose clamp.



15. Install the provided coupling hose #084055 onto the filter adapter as shown and secure with the provided hose clamp.



16. Remove the pressure sensor from the factory air box as shown.



17. Install the pressure sensor into the K&N® intake tube and secure with the provided hardware.



18. Install the K&N® intake tube into the hose at the plenum and then into the hose at the filter adapter and then secure with the provided hose clamps.



19. Reconnect the pressure sensor electrical connection.



20. Reconnect the vehicle's negative battery cable. Double check to make sure everything is tight and properly positioned before starting the vehicle.

21. It will be necessary for all K&N® high flow intake systems to be checked periodically for realignment, clearance and tightening of all connections. Failure to follow the above instructions or proper maintenance may void warranty.

ROAD TESTING:

1. Start the engine with the transmission in neutral or park, and the parking brake engaged. Listen for air leaks or odd noises. For air leaks secure hoses and connections. For odd noises, find cause and repair before proceeding. This kit will function identically to the factory system except for being louder and much more responsive.

2. Test drive the vehicle. Listen for odd noises or rattles and fix as necessary.

3. If road test is fine, you can now enjoy the added power and performance from your kit.

4. K&N Engineering, Inc., requires cleaning the intake system's air filter element every 100,000 miles. When used in dusty or off-road environments, our filters will require cleaning more often. We recommend that you visually inspect your filter once every 25,000 miles to determine if the screen is still visible. When the screen is no longer visible some place on the filter element, it is time to clean it. To clean and re-oil, purchase our filter Recharger® service kit, part number 99-5050 or 99-5000 and follow the easy instructions.

STREET LEGAL IN MOST STATES

**NOT LEGAL FOR USE IN CA & OTHER STATES
ADOPTING CA EMISSIONS STANDARDS**

See our catalog or knfilters.com for CARB status on each part for a specific vehicle

* FREE K&N® decal To register your warranty, please see us online at knfilters.com/register. FREE K&N® decal *

• 1455 CITRUS ST., P.O. BOX 1329, RIVERSIDE, CA., U.S.A. 92502 • TECH SERVICE 800-858-3333 • FAX 951-826-4001
• e-mail: tech@knfilters.com • WWW: <http://www.knfilters.com>

19641
11/4/13