



# TYPHOON INTAKE SYSTEMS

NOT LEGAL FOR SALE OR USE ON ANY POLLUTION CONTROLLED MOTOR VEHICLE IN CALIFORNIA OR STATES ADOPTING CALIFORNIA EMISSION PROCEDURES.  
See knfilters.com for CARB status on each part for a specific vehicle

## INSTALLATION INSTRUCTIONS

**69-3539TB**  
**FORD**  
**2016-17 Focus RS**  
**L4-2.3L Ecoboost**

**TOOLS NEEDED:**

- Flat blade screw driver
- Ratchet
- Extension
- 8mm socket
- 4mm allen key

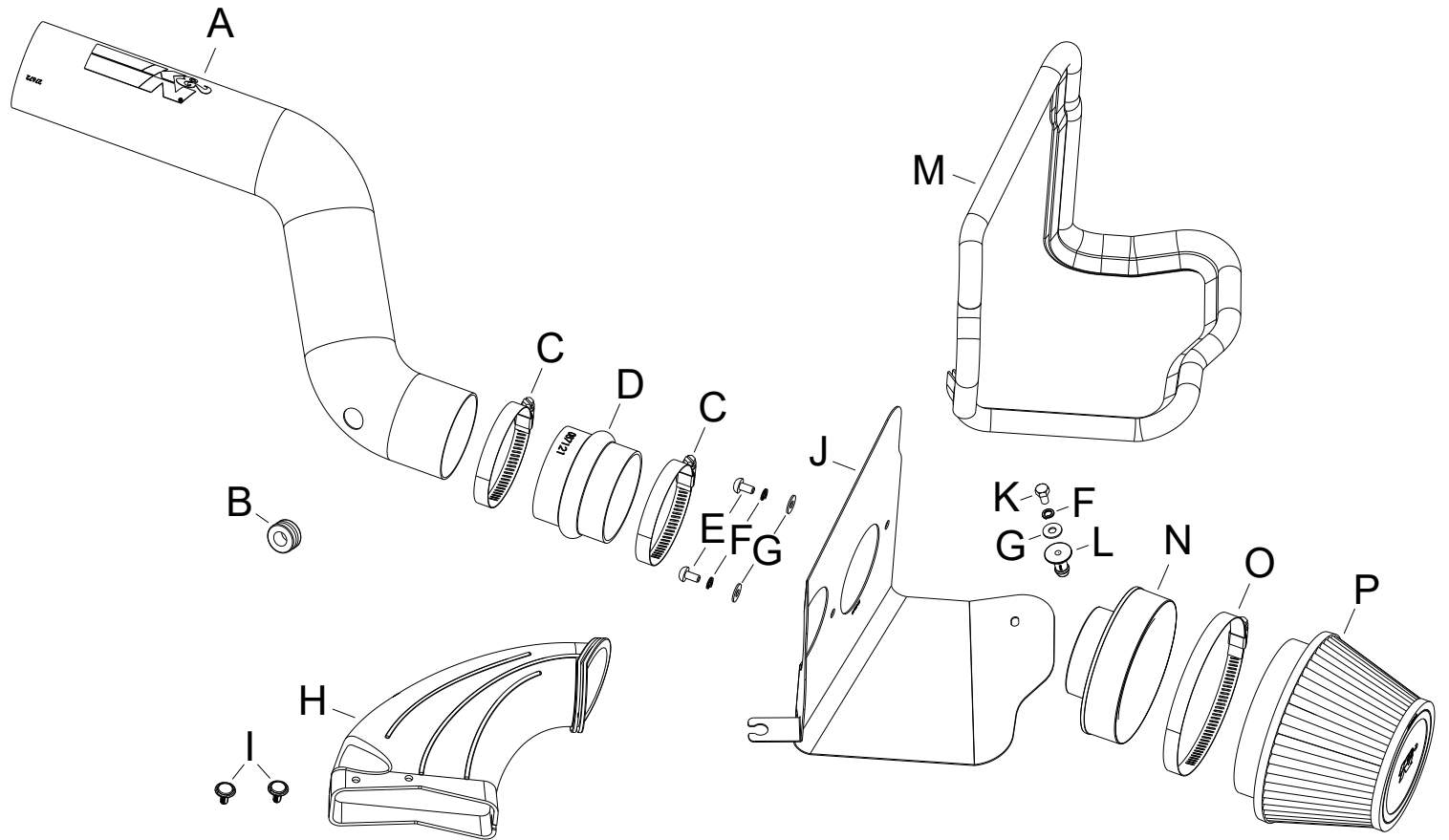

**PARTS LIST:**

Description	Qty.	Part #	Description	Qty.	Part #	Description	Qty.	Part #
A INTAKE TUBE	1	27672B	G WASHER; 6MM FLAT, SS	3	08269	M EDGE TRIM (46")	1	102487
B GROMMET; 1"OD, 1/2"ID, 1/2"	1	08064	H HOSE; FRESH AIR INTAKE	1	08669	N ADAPTER; FILTER, 3.0"OD	1	21569
C HOSE CLAMP #48	2	08601	I RIVET, TUFLOK, .246HL, .197	2	345010	O HOSE CLAMP; #80	1	08694
D HOSE; 3" ID X 2-1/2" L HUMP	1	087121	J HEAT SHIELD	1	073245	P FILTER CHARGER	1	RU-5163
E BOLT; M6 X 1.00" 12MM, SS	2	07794	K BOLT; M6 X 1.00 X 12MM, SS	1	07727			
F WASHER, M6 SPLIT LOCK ZINC	3	1-3025	L MOUNT, PLASTIC AIRBOX	1	8-186-1			

**If you need any assistance please call 1-800-858-3333 to speak with a representative in our Customer Service Center before returning the product.**

**NOTE: FAILURE TO FOLLOW INSTALLATION INSTRUCTIONS AND NOT USING THE PROVIDED HARDWARE MAY DAMAGE THE INTAKE TUBE, THROTTLE BODY AND ENGINE.**

**TO START:**

1. Turn off the ignition and disconnect the negative battery cable.  
**NOTE: Disconnecting the negative battery cable erases pre-programmed electronic memories. Write down all memory settings before disconnecting the negative battery cable. Some radios will require an anti-theft code to be entered after the battery is reconnected. The anti-theft code is typically supplied with your owner's manual. In the event your vehicles anti-theft code cannot be recovered, contact an authorized dealership to obtain your vehicles anti-theft code.**



2. Lift off the engine cover and remove it from the vehicle.



3. Remove the bolt securing the factory intake tube to the engine shown. Next loosen the hose clamps and unhook the vent line from the intake tube and remove the intake tube from the vehicle.



4. Disconnect the inlet air temperature sensor electrical connection.



5. Release the inlet air duct from the air box.



6. Lift and dislodge the air box from its mounting grommets and then remove the air box from the vehicle.  
**NOTE: K&N Engineering, Inc., recommends that customers do not discard factory air intake.**





7. Remove the inlet air duct from the core support.



8. Install the filter adapter into the heat shield and secure with the provided hardware.



9. Install the provided edge trim onto the heat shield.

**NOTE: Some trimming of the edge trim will be necessary.**

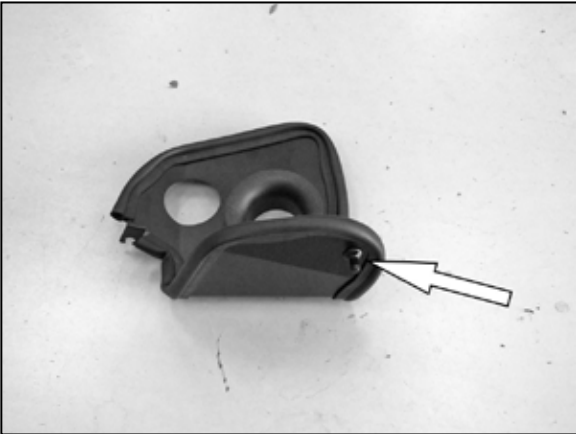

10. Install the heat shield mounting stud onto the heat shield and secure with the provided hardware.



11. Remove the inlet air temperature sensor and mounting post from the factory air box.

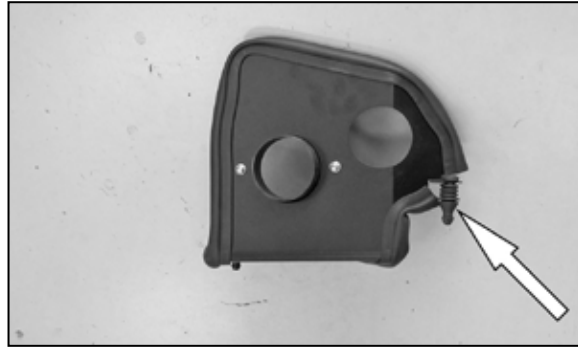

12. Install the mounting post from the previous step onto the K&N® heat shield as shown.



13. Install the heat shield assembly into the vehicle so the mounting studs insert into the grommets.



14. Install the provided coupler hose (087212) onto the filter adapter and secure with the provided hose clamp.



15. Install the grommet provided and the factory inlet air temperature sensor into the K&N® intake tube as shown.

**NOTE: Remove the O-Ring from the inlet temperature sensor before installing it into the grommet.**



16. Unhook the wiring harness clip from the mounting stud, route the harness next to the coil and fuel line and secure the harness to the fuel line with the provided tie wrap.



17. Install the K&N® intake tube into the factory coupler and then into the K&N® coupler, adjust the tube for best fit and then secure with the provided hose clamps.



18. Reconnect the inlet air temperature sensor electrical connection.



19. Install the K&N® air filter onto the filter adapter and secure with the provided hose clamp.  
**NOTE: Drycharger® air filter wrap; part # RU-5163DK is available to purchase separately. To learn more about Drycharger® filter wraps or look up color availability please visit <http://www.knfilters.com>.**



20. Install the K&N® fresh air duct onto the core support and into the K&N® heat shield.



21. Using the K&N® Fresh air duct as a guide, mark the two hole locations onto the fresh air duct in the core support. Next remove the K&N® fresh air duct and drill two 1/4" id holes into the factory fresh air duct in the core support at the marked locations.



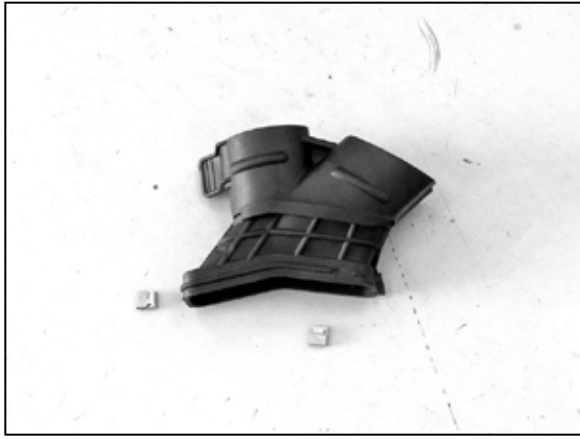

22. Remove the two clips from the factory inlet air hose.



23. Install the two clips from the previous step onto the K&N® fresh air duct in the same position as the factory.



24. Install the K&N® fresh air duct into the heat shield and core support as shown and secure with the two provided retaining clips.  
**NOTE: be sure to check the hood release cable to see if it became unhooked during the duct assembly and attach if necessary.**



25. Reinstall the engine cover.



26. Reconnect the vehicle's negative battery cable. Double check to make sure everything is tight and properly positioned before starting the vehicle.

27. It will be necessary for all K&N® high flow intake systems to be checked periodically for realignment, clearance and tightening of all connections. Failure to follow the above instructions or proper maintenance may void warranty.

#### ROAD TESTING:

1. Start the engine with the transmission in neutral or park, and the parking brake engaged. Listen for air leaks or odd noises. For air leaks secure hoses and connections. For odd noises, find cause and repair before proceeding. This kit will function identically to the factory system except for being louder and much more responsive.

2. Test drive the vehicle. Listen for odd noises or rattles and fix as necessary.

3. If road test is fine, you can now enjoy the added power and performance from your kit.

4. K&N Engineering, Inc., requires cleaning the intake system's air filter element every 100,000 miles. When used in dusty or off-road environments, our filters will require cleaning more often. We recommend that you visually inspect your filter once every 25,000 miles to determine if the screen is still visible. When the screen is no longer visible some place on the filter element, it is time to clean it. To clean and re-oil, purchase our filter Recharger® service kit, part number 99-5050 or 99-5000 and follow the easy instructions.

**NOT LEGAL FOR SALE OR USE ON ANY POLLUTION CONTROLLED MOTOR VEHICLE IN CALIFORNIA OR STATES ADOPTING CALIFORNIA EMISSION PROCEDURES.**

See [knfilters.com](http://knfilters.com) for CARB status on each part for a specific vehicle