



**SHOP CATEGORIES**

**WHY S&B**

**SHOP BY VEHICLE**



**0**

# INSTALL INSTRUCTIONS FOR 75-5160

 **PRINT**



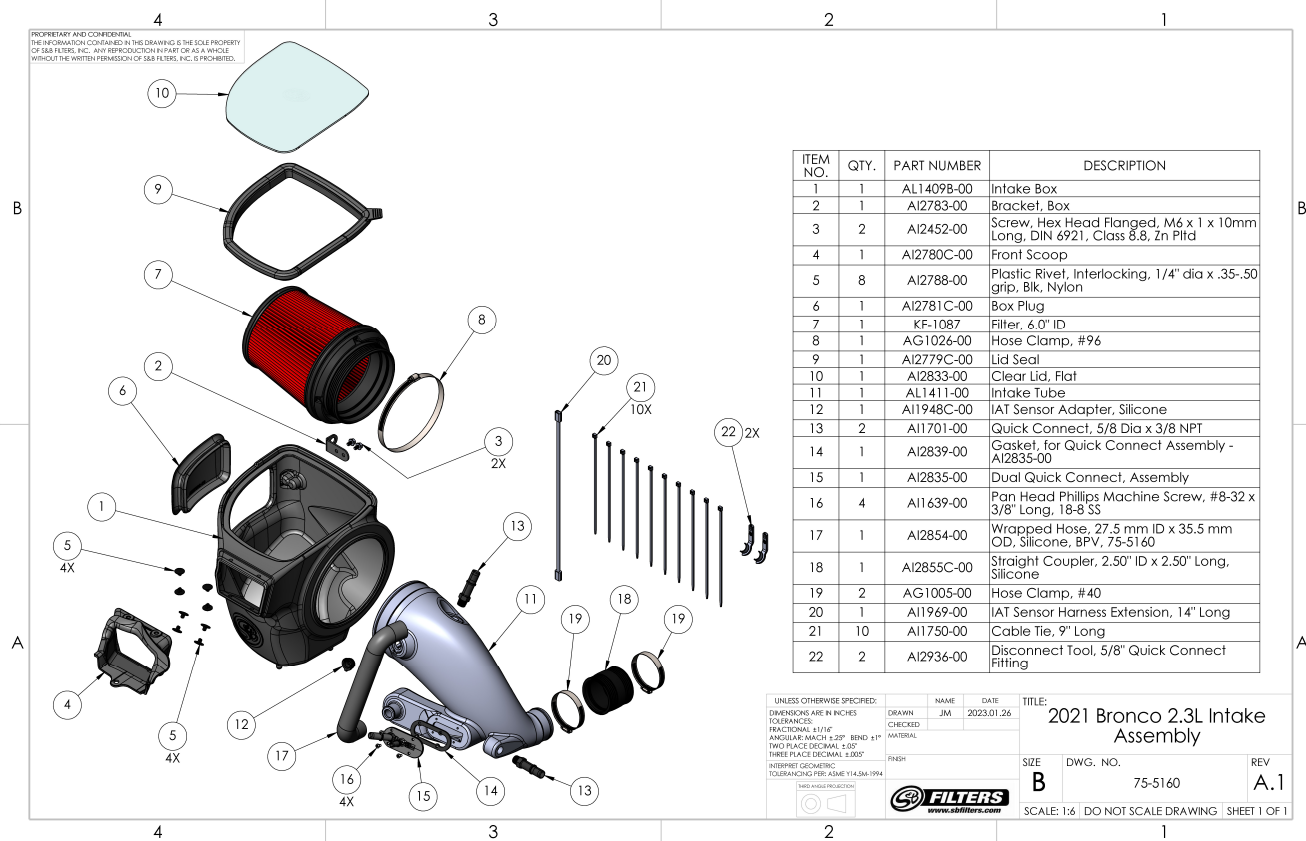

## STEP 1

With the ignition switched off, make sure the vehicle is in Park and the parking brake set. Make sure the engine has cooled down.

**CAUTION:** The turbocharger compressor vanes can be damaged by small particles. When removing engine air intake system components,

make sure no debris enter the system.

## STEP 2

Pop out the stem and remove the push-in rivet securing the stock front inlet. Set the push-in rivet aside, it will be reused later.

Tools Required: Panel Popper



## STEP 3

Remove the connector from the IAT sensor. Push down to release the locking tab and then pull the connector away from the sensor.



## STEP 4

Remove the ribbed push-in retainer clips from the intake box. Use a panel popper to carefully remove the retainer clips.

Tools Required: Panel Popper



## STEP 4 (IMAGE 2)



## STEP 5

Pull out the green colored locking clip by pushing up in the two small green tabs and then pushing the tabs in the direction of the red arrow in the photo. Then remove the quick connect fitting from the

flexible intake coupler that is attached to the intake box.

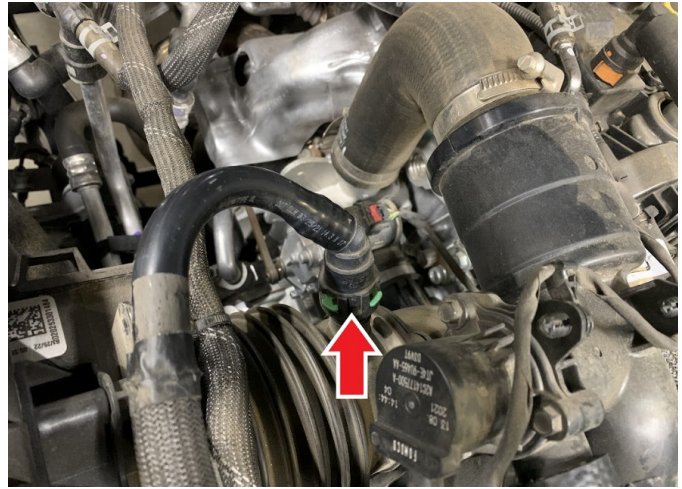

**STEP 5 (IMAGE 2)**



## STEP 6

Loosen the hose clamp attached to the flexible coupler.

Tools Required: 7mm Socket/Wrench with 3" Extension or 7mm Nut Driver

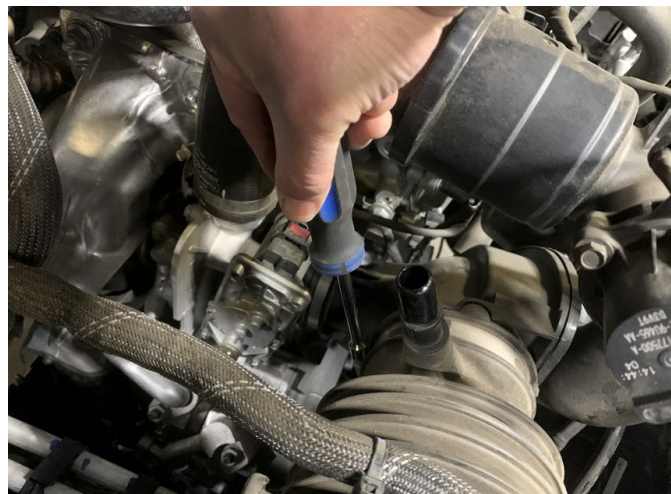

## STEP 7

Remove the screw that mounts the rear corner of the intake box to the fender frame. Set the screw aside to be reused later.

Tools Required: 10mm Socket/Wrench



## STEP 8

Firmly but carefully rock and

lift the intake box free from the lower grommets. Lift and remove the intake box from the vehicle.



## STEP 9

Make sure the bottom box grommets stayed in the vehicle and did not get pulled out with the intake box.

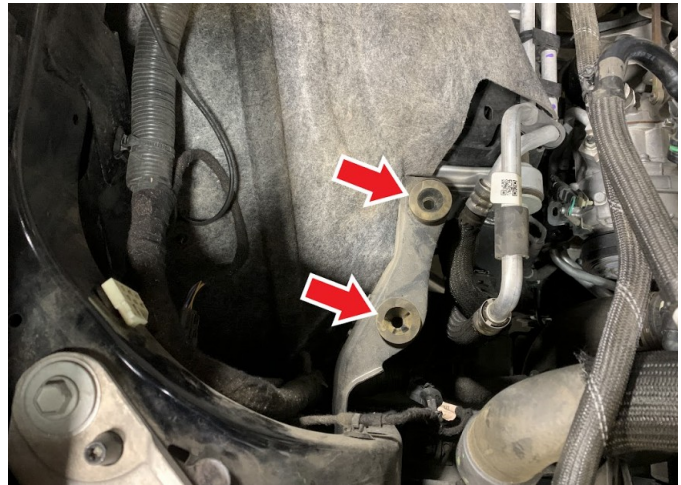

## STEP 10

Using adjustable pliers, expand the bypass hose clamp by squeezing the tabs together and remove the hose from the bypass valve. Set the hose clamp aside to be reused later.

Tools Required: Adjustable  
Pliers



## STEP 11

Remove the larger vapor quick connect fitting from the intake tube. Pull out the green locking tab then depress the white release clip and remove the quick connect fitting.



## STEP 12

Remove the smaller vapor quick connect fitting from the intake tube. Depress both green tabs to release and

remove the quick connect fitting.

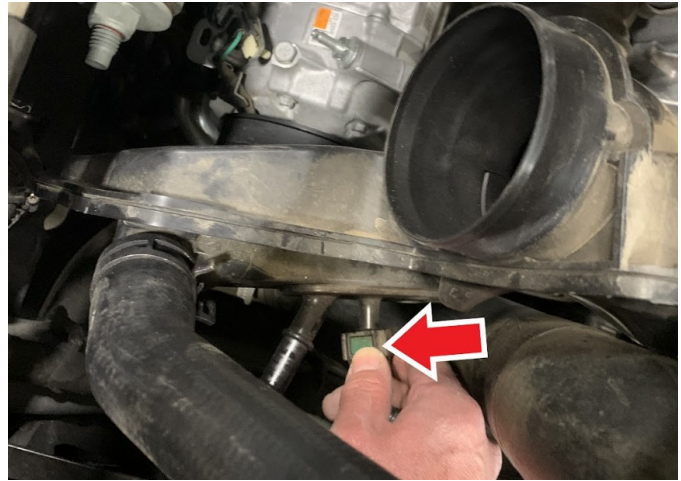

### STEP 13

Remove the crankcase vent quick connect fitting from the intake tube. Using supplied Disconnect Tool (22), insert the Tool inside the quick connect fitting and rotate to the position shown. Insert the second Disconnect Tool (22) inside the quick connect fitting and remove the fitting from the intake tube.

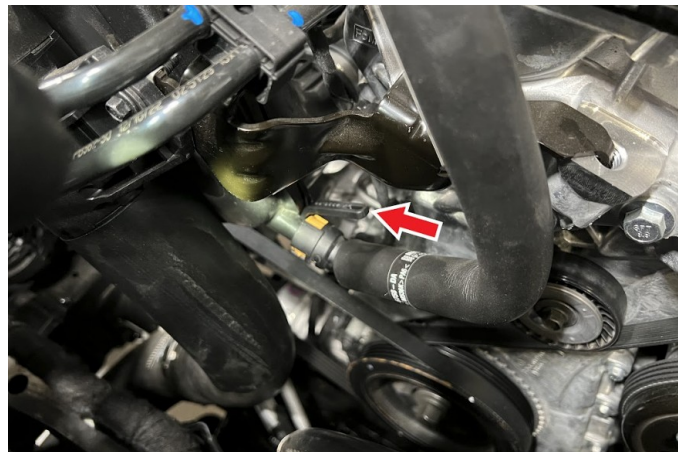

Tools Required: (2) Quick Disconnect Tools (Item 22).

### STEP 13 (IMAGE 2)



### STEP 13 (IMAGE 3)

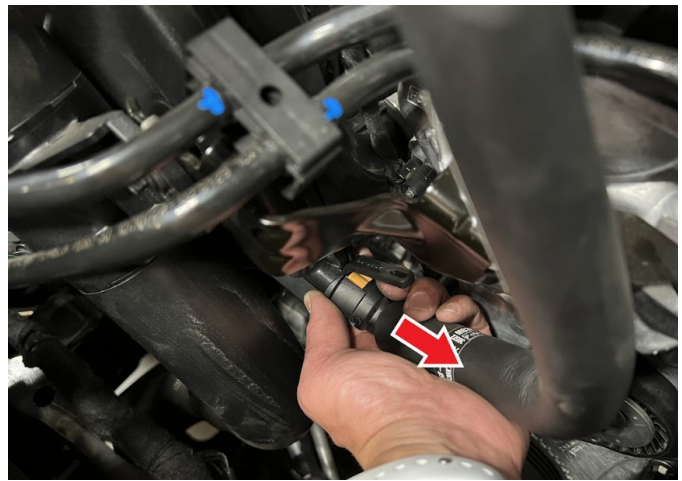

### STEP 14

Loosen the hose clamp connecting the intake tube to the turbo inlet.

Tools Required: 7mm Deep Socket with 3" Extension



## STEP 15

Remove the intake tube from the engine.

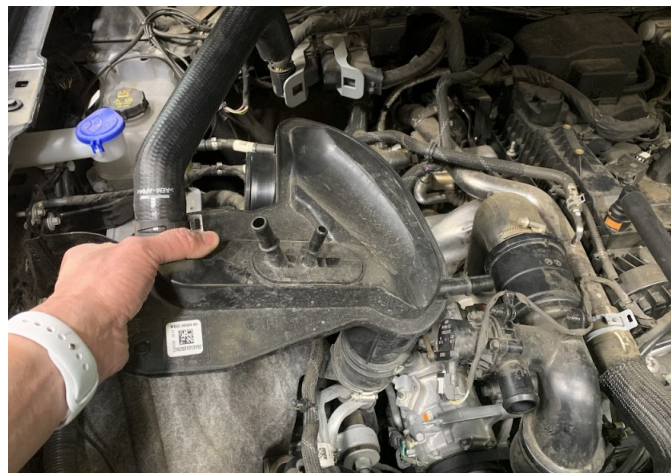

## STEP 16

Install the Box Bracket (2) to the Intake Box (1) using two Screws (3). Tighten the Screws to secure the Bracket.

Tools Required: 10mm  
Socket/Wrench



## STEP 17

Remove the shoulder bushing and grommet from the stock intake box and install them to the Box Bracket (2). Note the orientation of the grommet and bushing when installing them to the Box Bracket.



## STEP 17 (IMAGE 2)



## STEP 18

Install the Front Scoop (4) to the Intake Box (1). Use the Plastic Rivets (5) to secure the Scoop to the Intake Box. There are (4) holes in the Intake Box for the Scoop and each hole will have (2) Plastic

Rivets that interlock to each other and sandwich the Scoop to the Intake Box.



## STEP 19

Determine if you want to install the Box Plug (6) onto the Air Box (1). For optimal performance, we recommend that the intake be used without the Plug except in conditions of extreme heat. If the Box Plug is desired, simply press the Box Plug into the Box opening until it snaps fully into place.



## STEP 20

Install the Intake Box (1) into the vehicle. Make sure that the box prongs are aligned with the factory grommets. Push down on the airbox to make sure that the prongs are completely seated.

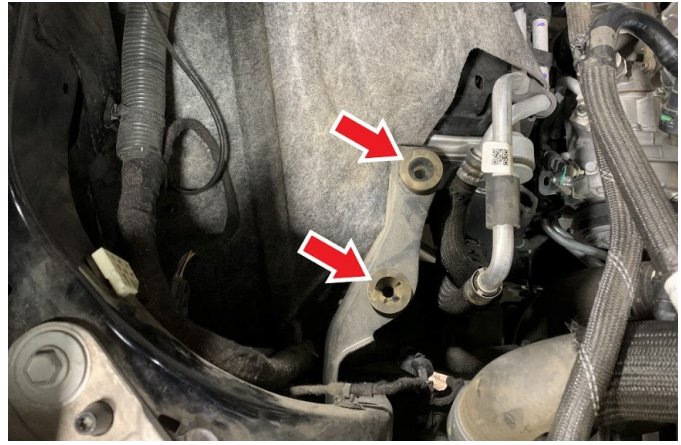

### **STEP 20 (IMAGE 2)**

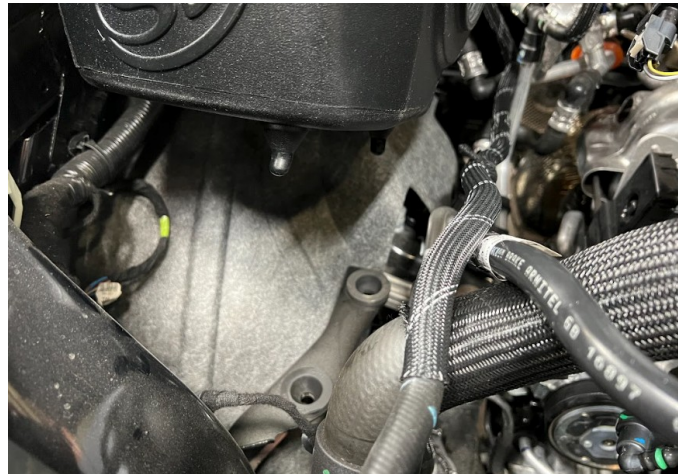

### **STEP 20 (IMAGE 3)**



## STEP 21

Align the grommet hole in the Box Bracket (2) with the threaded hole in the fender frame and reuse the screw removed in Step 7 to fasten the Box Bracket to the fender frame. Tighten the screw.

Tools Required: 10mm  
Socket/Wrench



## STEP 22

Reinstall plastic rivet removed in Step 2 to secure the Front Scoop (4).



## STEP 23

Install the Filter (7) into the Intake Box (1). Insert the Filter flange first through the

top opening of the Box.  
Center the Filter flange with the round filter opening of the Box. Make sure that all around the tip of the tapered snap-in feature of the filter is inside the round filter opening before you use the filter flange to pull the filter until the tapered feature completely snaps around the outside of the round opening.

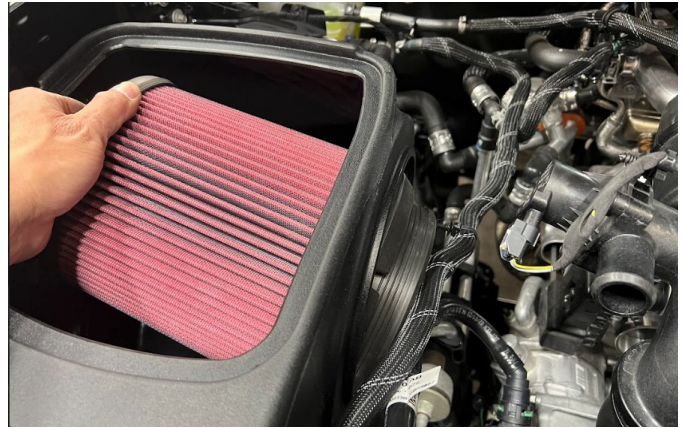

### **STEP 23 (IMAGE 2)**

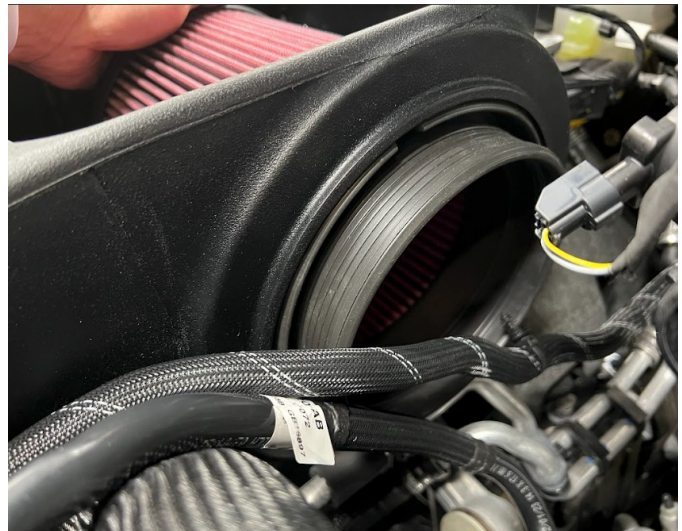

### STEP 23 (IMAGE 3)



### STEP 24

Place the Gasket (14) on to the Tube (11) making sure the holes line up with the threaded holes in the Tube.



### STEP 25

Install Dual Quick Connect (15) over the Gasket (14) making sure the holes of the Dual Quick Connect and Gasket line up with the threaded holes on the Tube. Using Screws (16), fasten and tighten the Dual Quick Connect to the Gasket and Tube.

Tools Required: Phillips  
Screwdriver



## STEP 26

Install the IAT Sensor Grommet (12) to the Tube (11). Make sure the tab on the Grommet lines up with the notch in the Tube and the Grommet is fully seated in the Tube as shown.



## STEP 27

Remove the IAT sensor from

the stock intake. Lean the IAT Sensor back as you rotate it counterclockwise so that the tab on the sensor goes over the locking ramp. Once the sensor tab is passed the locking ramp it can be pulled out and removed.

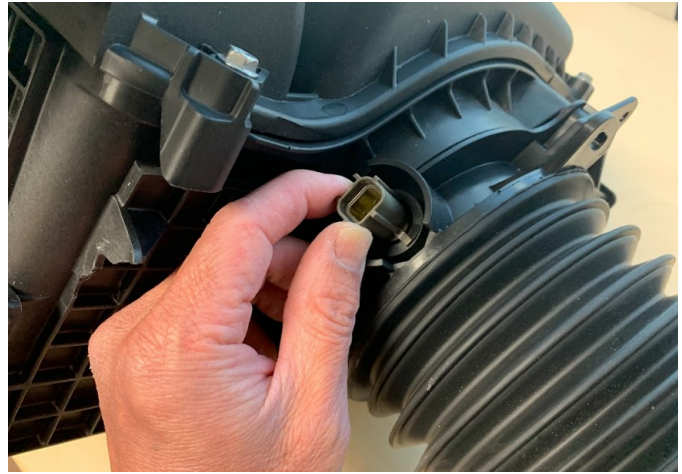

## STEP 28

Install the IAT sensor into the IAT Sensor Grommet (12). First line up the sensor tab so that it is between the arrowhead and locking ramp on the Grommet. Then insert the sensor so that the tab is touching the Grommet. Finally twist the IAT sensor so that the tab goes over the ramp on the Grommet. A properly installed IAT sensor should look like the picture shown.



## STEP 29

Install Coupler (18) to the Turbo inlet. Position the Hose Clamp (19) so that the clamp nut is accessible as shown and tighten the Hose Clamp.

Tools Required: 6" Socket Extension or 3" + 3" Socket Extension, 8mm Socket/Wrench or 5/16" Nut Driver.



## STEP 30

Install the second Hose Clamp (19) on to the Coupler (18) but leave this Hose Clamp loose.



## STEP 31

Install tube into the Coupler (18) and then into the Filter

(7) flange. Put the Hose Clamp (8) loosely over the Filter flange first. Take your time to carefully snake the Tube into the Coupler first and then work the Tube into the Filter afterwards.

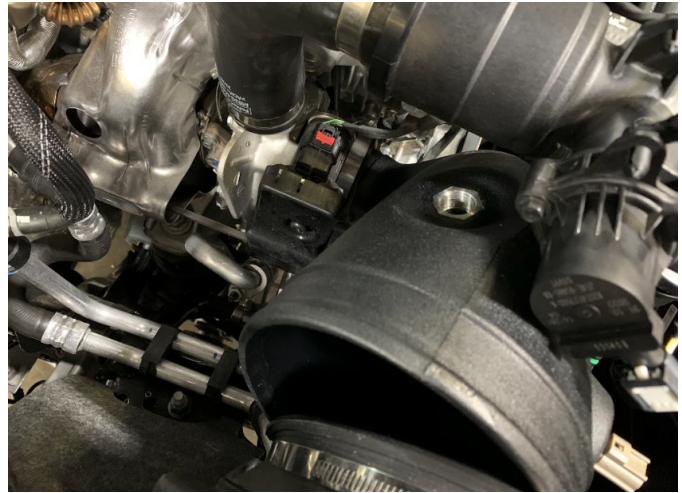

### STEP 31 (IMAGE 2)



### STEP 31 (IMAGE 3)

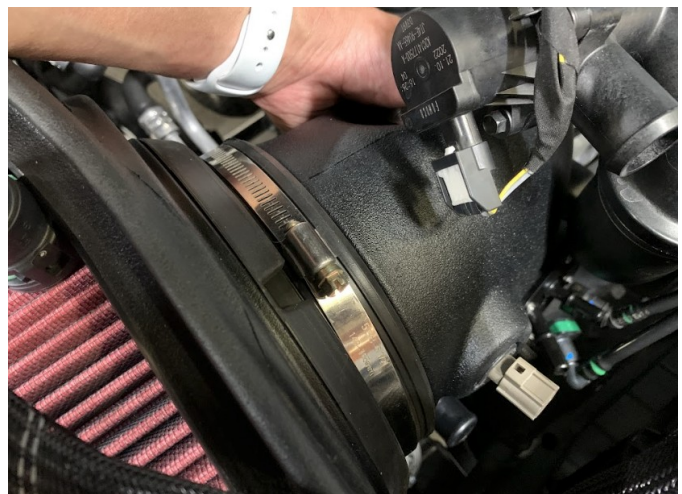

## STEP 32

Fully insert the Tube (11) into the Coupler (18) and then move the Hose Clamp (19) into the hose clamp groove on the Coupler and tighten the Hose Clamp.

Tools Required: 6" Socket Extension or 3" + 3" Socket Extension, 8mm Socket/Wrench or 5/16" Nut Driver.

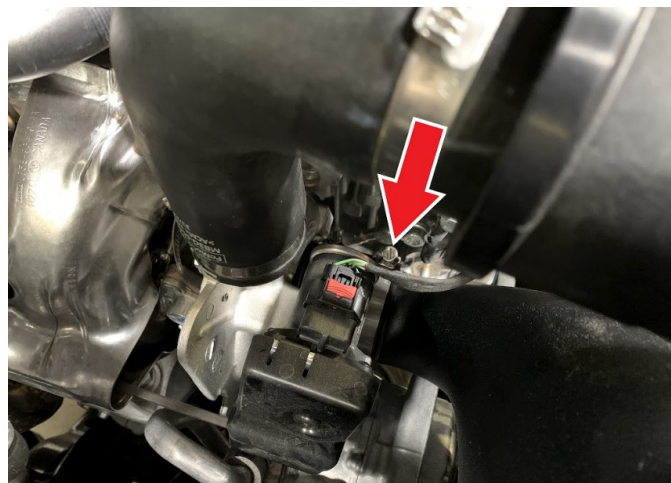

## STEP 33

Fully insert the Tube (11) into the Filter (7) flange and tighten the Hose Clamp (8).

Tools Required: 3" Socket Extension, 8mm Socket/Wrench or 5/16" Nut Driver.

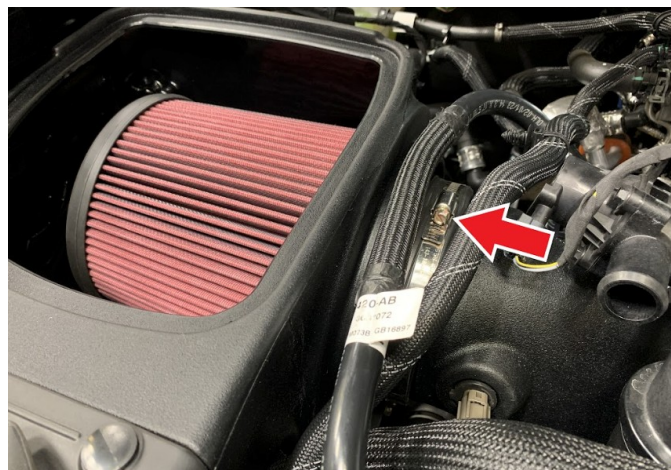

## STEP 34

Install Quick Connect (13) to the bottom of the Tube (11) until the NPT threads are tight. Do not over tighten.

Tools Required: 3/4" Open/  
Box Combination Wrench

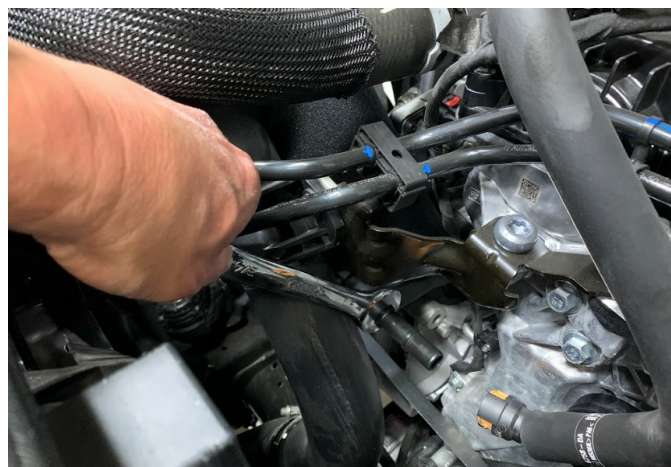

## STEP 35

Install Quick Connect (13) to the top of the Tube (11) until the NPT threads are tight. Do not over tighten.

Tools Required: 3/4" Open/  
Box Combination Wrench



## STEP 36

Install the Wrapped Hose (17). The Wrapped Hose will

have a sharper 90 degree bend and a lesser 100 degree bend. The end with the sharper 90 degree bend will be installed on the Tube (11) and the lesser 100 degree bend will install onto the bypass valve. Place the factory hose clamps over the Wrapped Hose in a position so you can install both ends of the Hose.

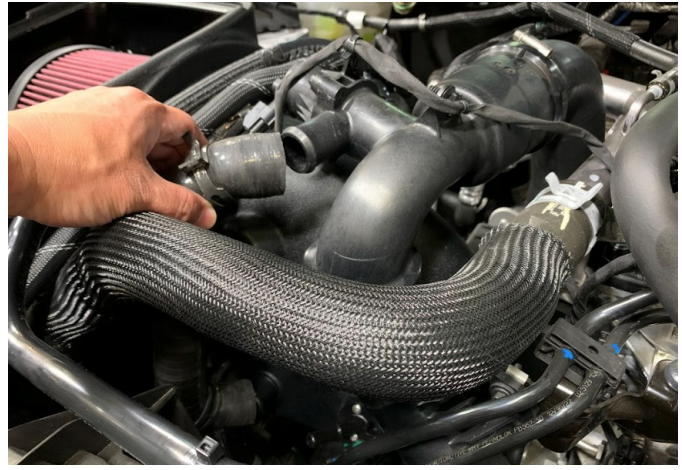

## STEP 37

Squeeze the lower clamp to insert the Hose fully onto the Tube and then release the clamp to secure the Hose. Squeeze the upper clamp to insert the Hose fully onto the bypass valve and then release the clamp to secure the Hose.

Tools Required: Tools  
Required: Adjustable Pliers

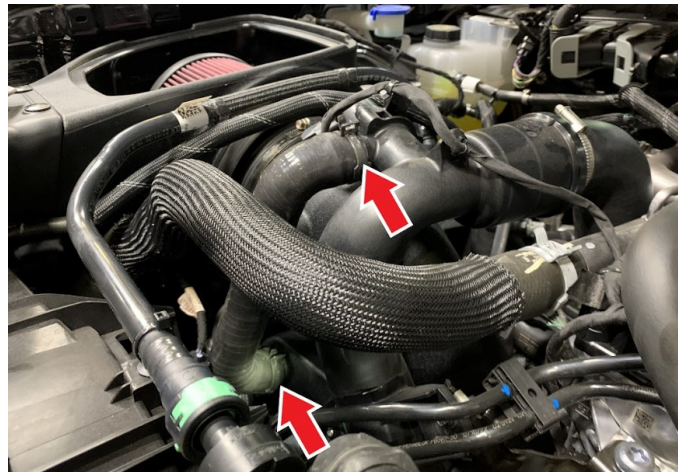

## STEP 38

Install the connector onto the IAT sensor. If your connector harness is not long enough to easily connect to the sensor, use the provided Harness Extension (20) and use Cable Ties (21) to hold the extra length together so that it is secured away from any hot or moving components and also not rubbing against any components.



## STEP 39

Install upper quick connect hose. Make sure the green locking tab is engaged after installing the quick connect hose.

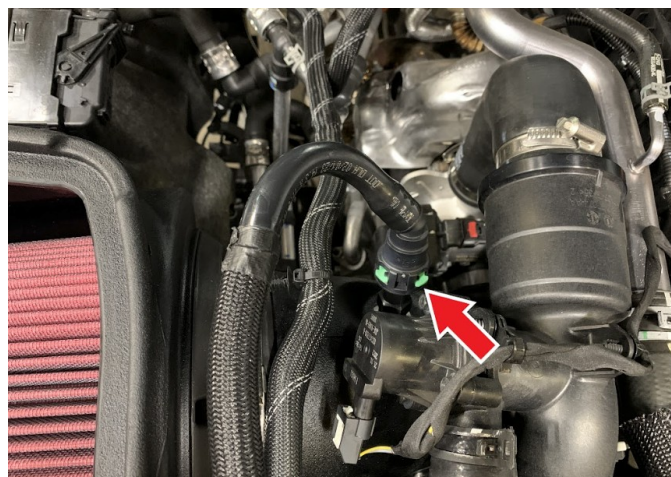

## STEP 40

Install the dual quick connect hoses. Make sure the green locking tab is engaged in the larger quick connect after installing the quick connect hose. Make sure the smaller quick connect locks into place as well.

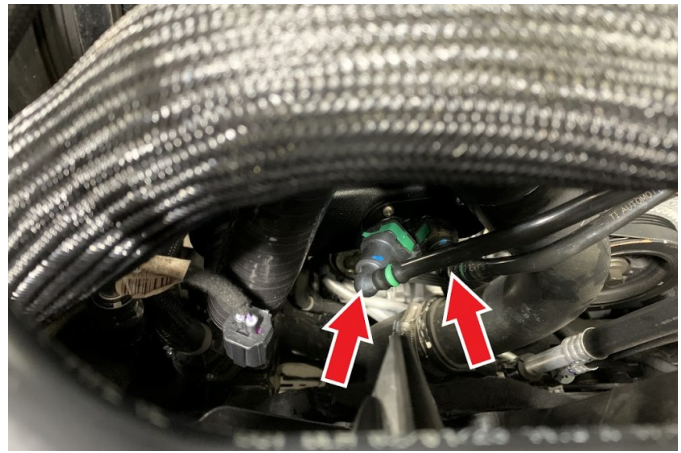

## STEP 41

Install lower quick connect hose. Make sure it is fully inserted and locked into place.

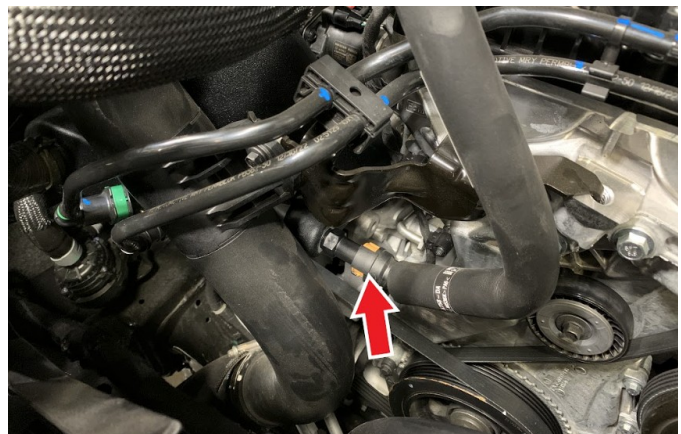

## STEP 42

Remove the protective covering over the Clear Lid (10) and then insert the Lid into the Lid Seal (9). Then install the Lid Seal with Lid onto the top opening of the Box. Start with one corner of

the Box and work your way around until the Lid Seal with Lid is fully snapped into the Box opening.



### STEP 43

Secure the loose coolant line to the upper quick connect hose with Cable Ties (21). Trim the excess Cable Tie with wire cutters.

Tools Required: Wire Cutters

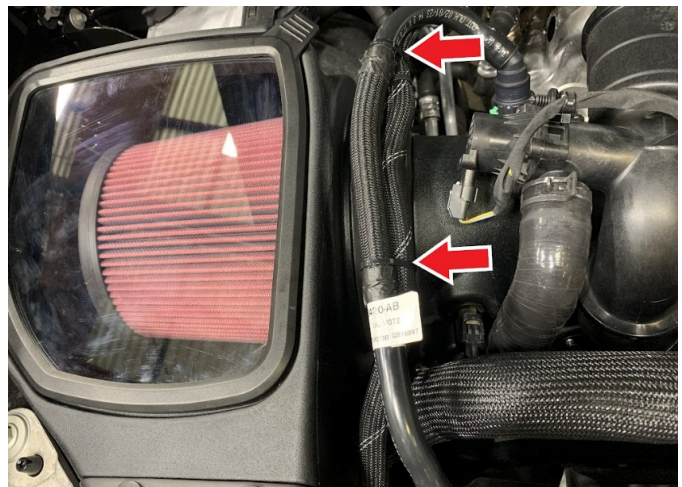

### STEP 44

Inspect your installation, make sure the kit is properly

positioned and all fasteners and hose clamps are secured. Keep all stock parts in case you would ever need to reinstall the stock intake assembly. If you are an installer, give the owner the QR code for the Installation Instructions so that he/she is aware of the "Periodically Check the Following" procedures given in the beginning of the Instructions. The Installation is now complete.



