



INSTALLATION INSTRUCTIONS

REAR CONVERSION KIT A111-2
(FORD 8" & 9" SMALL BEARING)
&
REAR CONVERSION KIT A111-3
(FORD 9" TORINO)

Thank you for choosing STAINLESS STEEL BRAKES CORPORATION for your braking needs. Please take the time to read and carefully follow these instructions to insure the ease of your installation as well as the proper performance of the complete system.

Before beginning your installation, please verify you have received all the parts indicated on the packing slip. If you believe anything to be missing or incorrect, please call our Customer Service Department at 716-759-8666.

To assure your installation will go safely and smoothly, have the following items on hand to assist you:

JACK & JACK STANDS
LUG WRENCH
TORQUE WRENCH
SOCKET SET
BRAKE CLEANER

WRENCH SET
TUBE WRENCHES
MALLET
BRAKE FLUID

These kits use the following pads:

REVISED TO LEVEL 6 2/27/12

SSBC#: 1047

FMSI#: D-347

TIP: BEFORE BEGINNING INSTALLATION, TURN ALL FITTINGS & FASTENERS WITH PENETRATING OIL.

1. **Drum Brake Removal**

- a) Raise the car until the tires and wheels clear the floor and support the car on jack stands. Remove the tire and wheel assemblies from the drum.
- b) Remove the brake drums from the axle. If the brake drum will not come off easily, retract the shoes by inserting a narrow screwdriver through the brake adjusting slot and disengage the adjusting lever from the adjusting screw. While holding the lever away from the adjusting screw, back off the adjuster.
- c) Remove the brake shoes and all the brake hardware.
- d) Disconnect parking brake cable from the actuator and pull through backing plate after compressing the retaining clip.
- e) Disconnect the rigid brake line from the back of the wheel cylinder. Be sure to use plenty of penetrating oil on the fitting prior to removal and always use a tube wrench. At this point, the ends of the lines should be capped off to avoid letting the master cylinder run dry. If the master does go dry, it must be bench bled off the vehicle. A rubber vacuum cap works well to cap off the steel lines.



BE CAREFUL NOT TO GET BRAKE FLUID ON THE PAINT. IT CAN CAUSE SEVERE DAMAGE.

- f) Remove the four nuts and bolts that secure the backing plate to the axle flange.
- g) Carefully pull the axle shafts out of the rear end being careful not to damage the axle bearings or seals.
- h) The backing plate assembly can then be removed and discarded.

2. **Axle Shafts**

- a) The lug studs in the axles must be replaced with the longer ones supplied in the kit. The studs can either be pressed out or knocked out with a hammer if the axle is carefully supported in a vise.
- b) The new lug studs will need to be pressed into the axle shafts. If you do not have a press available any local machine shop will be able to perform this operation.

3. **Installation of Conversion Kit**

- a) Carefully slide axle shaft approximately 7/8 of the way back into the rear end housing.
- b) Place the two piece caliper mounting plate (marked "L" (drivers side) and "R") over the axle between the bearing and the bearing retainer plate. The circular depression on the back of the plate becomes the new bearing retainer. Make sure the bearings fit into this depression. Place one of the large split shims into the circular depression on the bracket. The shim should be between the face of the bracket and the axle bearing. This shim will correctly position the bearing in the axle housing to maintain proper axle and play.
- c) Carefully slide the axle shaft all the way back into the axle housing. This will sandwich the mounting plate between the end of the axle tube and the original bearing retainer plate. Secure the assembly with the 3/8-24 x 1-1/4" bolts and 3/8-24" elastic stop nuts supplied with the kit. These bolts should be torqued to 40 ft - lbs.

- d) Install the 7/16"-20 x 2" bolts from the kit through the four outer holes in each mounting plate. These bolts should be installed from the outside.
- e) On the backside of the plate, slide the four 3/4" tubular spacers over each of the bolts.
- f) Install the caliper mounting straps on the four mounting bolts. Note that the straps are not the same length. The longer strap will go on the bottom and the shorter ones will go on top. The straps should point towards the rear of the car and the ends should point in towards each other. Next, install the parking brake cable L-bracket on the rear lower bolt and install the 7/16"-20 x 2" elastic stop nuts from the kit on each of the bolts. Torque the bolts to 35-40 ft/lbs.

4. Rotors

- a) Thoroughly clean rotors with brake cleaner to remove the protective coating.
- b) If the axle center pilot is 2-7/16", use the bushing provided to properly center the rotor on the axle.
- c) Slide the rotor onto the axle shaft and temporarily secure it into place using one lug nut.

5. Caliper Mounting

- a) Calipers are marked "Left" and "Right". Be sure to install them on the correct sides. The bleeder screws must be pointing up.
- b) Install the male threaded end of the rubber flex hoses provided into the brass blocks. Install the block end of the hose onto the calipers using the hollow banjo bolts and copper washers provided with the kit. Orient the hoses so they are pointed toward the axle tube and torque the banjo bolts to 20-30 ft / lbs.
- c) Place caliper over the rotor and secure the caliper mounting straps using the 12mm-1 bolts supplied and torque them to 80-110 ft / lbs.
- d) Rebend the original steel lines so they can be connected to the flex hoses. Make sure to use a tube wrench so not to strip the line fittings.



MAKE SURE THE HOSES TAKE A SMOOTH BEND AND DO NOT BECOME KINKED.

- e) Feed the parking brake cables through the L-bracket and lock the spring clip on the outer housing into the bracket.
- f) Compress the spring and engage the cable end into the slot of the parking brake lever on the caliper. It may be necessary to let all the slack out in the cable to complete this step.

6. Master Cylinder and Proportioning Valve

- a) On many of the earlier cars, there was a residual pressure valve built into the master cylinder. The valve must be removed for proper operation of the rear disc. If your car was a later model or if the master cylinder has ever been replaced, this residual pressure valve may no longer be present.
- b) Remove the master cylinder from the car by unhooking the steel lines and brake pushrod.

- c) Using an easy out and a T-handle, remove the brass seat from the master cylinder port serving the rear brakes. The residual pressure valve is a small rubber flap which can be removed and discarded. The brass seat can then be reinstalled with a punch and a light tap. The tightening of the steel line upon reinstallation will accomplish the final seating.
- d) The master cylinder must then be bench bled (refer to attached page) prior to installation.
- e) The adjustable proportioning valve (optional) with the kit can then be installed in the line going from the brass block to the rear brakes (P/N A0707).
- f) The line from the master cylinder or brass block must be connected to the in port of the adjustable valve and the line going to the rear brake will be connected to the out port.



THE BRASS ADAPTERS MUST BE INSTALLED INTO THE ADJUSTABLE VALVE PRIOR TO CONNECTING THE LINES. THE LINES CANNOT BE THREADED DIRECTLY INTO THE VALVE. DO NOT USE PIPE DOPE OR OTHER THREADED SEALANTS!

7. Filling and Bleeding system

- a) It is advisable to replace the brake fluid if the color is brown or muddy. This is due to water that has been absorbed by the fluid which will eventually corrode the brake lines and master cylinder. This absorbed moisture can also cause a vapor lock situation under extreme braking conditions. Flush system with clean brake fluid and replace with a good grade of disc brake fluid. DOT 3 or DOT 4 fluids are acceptable.
- b) The simplest and most effective way to bleed your brakes is to use the gravity bleeding approach as follows:
 - 1) With calipers installed, make sure all fittings are tight and master cylinder is topped off.
 - 2) Open one bleeder screw at a time starting at the wheel farthest from the master cylinder and working your way back around the wheel closest to the master. With bleeder screw open, observe bleeder. At first the fluid will begin to escape with intermittent air bubbles. When the air bubbles stop and a steady flow of fluid is observed for several seconds, close the bleeder valve and move on to the next wheel.



MAKE SURE TO KEEP A CLOSE WATCH OVER THE FLUID LEVEL INSIDE THE MASTER CYLINDER DURING THE BLEEDING PROCESS. NEVER LET THE RESERVOIR RUN DRY. ALWAYS KEEP IT AT LEAST 1/3 FULL.

- 3) After bleeding both wheels and topping of the master cylinder make 20-30 applications of the brake pedal. If a hard pedal is experienced, no further bleeding is required. If pedal is spongy, repeat bleeding process until a hard pedal is achieved.
- 4) With all bleeding complete, there should be approximately 3/4" to 1" of end play.
- 5) Power brake cars will experience a "drop off" of the pedal when the engine is started. This is a normal condition that signifies the booster is working.
- 6) Pedal end play can be adjusted by lengthening or shortening the pushrod between the pedal rod (or power brake output shaft) and the master cylinder.

This is best accomplished under the dash on standard brake cars and between the booster and the master cylinder on power brake cars.

8. Parking Brake Adjustment

- a) The caliper pistons adjust hydraulically by pumping the pedal. When a hard pedal is achieved, there should be a clearance between the pads and rotor of 1/32" to 1/16".



NOTE: IF THE PISTONS BECOME EXTENDED TOO FAR, THE INNER BRAKE PAD CAN BE REMOVED AND THE PISTON CAN BE SCREWED BACK INTO THE CALIPER USING NEEDLE NOSE PLIERS OR A CALIPER ADJUSTING TOOL AVAILABLE AT MOST PARTS STORES.

- b) Make sure the parking brake lever is in the full released position.
- c) Take up the slack in the parking brake cables by adjusting the nut on the threaded rod under the car. Cables should be adjusted until they are taught but not enough to move the parking brake levers on the calipers.
- d) Move the parking brake handle through its full travel several times. The parking brake should hold the car from rolling but create no brake resistance when in the full released position. Make sure the brake lever is returned all the way when the parking brake is released.

FINAL INSPECTION

- a) Once a hard pedal is achieved, all fittings and connections must be inspected to make sure there are no leaks. Also check the level in both reservoirs of the master cylinder and top off, if needed.
- b) Put wheels back on the car and turn wheel by hand to insure that the wheel spins freely and does not interfere with any brake components. If any interferences are detected, DO NOT drive vehicle until problem can be identified and corrected. An optional wheel spacer kit is available from SSBC (P/N A2309-1).
- c) If the caliper interferes with the wheel, it may be necessary to use the 3/16" wheel spacers to clear the wheels. Do not use more than two of the spacers on each wheel.
- d) When you are sure there are no interferences and the pedal is firm, torque the lug nuts and lower the car back onto the ground. Test drive the car and apply the brakes frequently to seat the pads.
- e) The rear brake pressure can be adjusted by turning the knob on the adjustable proportioning valve. It should be adjusted so the rear brakes do not lock up before the fronts.

NOTE: DO NOT USE ANTI-SQUEAK ADHESIVE ON BACKS OF PADS. THIS WILL DEGRADE THE PERFORMANCE OF THE CALIPER!

**DO NOT DRIVE IN TRAFFIC UNTIL THE BRAKES SAFELY STOP THE CAR A SAFE DISTANCE
WITHOUT A SPONGY PEDAL FEEL!**

BRAKING TESTS SHOULD ALWAYS BE DONE IN A SAFE OPEN AREA!

TECH LINE -- If technical help is required, please call 716-759-8666.

NOW ENJOY TRUE PERFORMANCE BRAKING!!

NOTE: For frequently asked questions and technical reference information please visit the tech section of our website at www.ssbrakes.com.

REPLACEMENT PARTS & SPECIFICATIONS

The calipers and brake pads used in this conversion kit are the same as those used from the factory on 1987-88 Ford Thunderbird Turbo Coupe. If you have a problem locating replacement pads, have your parts store reference the F.M.S.I. #D347. If you should need replacement rotors, they are only available from your distributor or **STAINLESS STEEL BRAKES CORPORATION** directly.

If you are using or ever plan on using aftermarket axle shafts, the following rotor dimensions will be important to keep in mind.

ROTOR HAT INNER DIAMETER	-	6.330"
ROTOR HAT THICKNESS	-	.240"
PILOT HOLE INNER DIAMETER	-	2.840"

How and why do I bench bleed a master cylinder?

When installing or replacing a master cylinder, it is critical that all air is removed from the master cylinder. This can easily be done by bench bleeding the master cylinder prior to installation. Using the SSBC master cylinder bleeder kit (#0460):

- 1) Place your master cylinder in a vise by the ears (not body). Make sure it is level.
- 2) Attach a piece of clear plastic hose to the short end of one of the plastic nozzles. Do the same to the other hose and nozzle.
- 3) Clip the plastic bridge to the wall and push the ends of the hose through the holes so they are SUBMERGED in the reservoir on either side of the wall.
- 4) Press the tapered end of the nozzle FIRMLY into the cylinder port hole with a twisting motion. Repeat this procedure on the other port hole.
- 5) Fill the reservoir with CLEAN brake fluid recommended by the manufacturer.
- 6) Using full strokes, push the piston in, then release. Do this until ALL the air bubbles have disappeared from the clear plastic hose. **(CAUTION-MASTER CYLINDER WILL NOT BLEED PROPERLY UNLESS HOSES ARE SUBMERGED IN BRAKE FLUID UNTIL THE BLEEDING PROCESS IS COMPLETED.)**

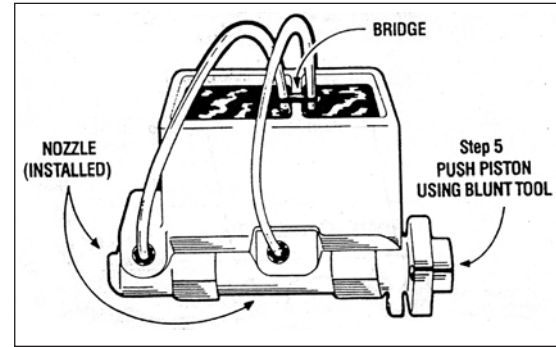

Now mount master cylinder and avoid brake fluid leaking out of front and rear ports during installation.

Bleeding steps for Dual Port Master Cylinder

If you have a master cylinder with dual port holes (4 port holes - 2 on each side), it is necessary to bleed both port sides of the master cylinder. If both sides of the master cylinder are not bled, there will be air trapped in the master cylinder and your brakes will not function properly.

To bleed dual port master cylinders:

- 1) Follow steps 1 - 6 above on the side you will be hooking the brake lines to. Plug the other side.
- 2) Once the air bubbles are no longer visible in the plastic hose, open the bleeder screws in the supplied plugs and allow the master cylinder to gravity bleed. **DO NOT** push the master cylinder piston in while the plugs are gravity bleeding.
- 3) When clear, steady streams of fluid are coming out of both bleeders, close and tighten the bleeders. Give the master cylinder piston several strokes, making sure there are still no bubbles present in the clear plastic tubes.
- 4) Remove the tubes and plastic fittings and mount the master cylinder on the vehicle being careful not to spill brake fluid on any painted surfaces.

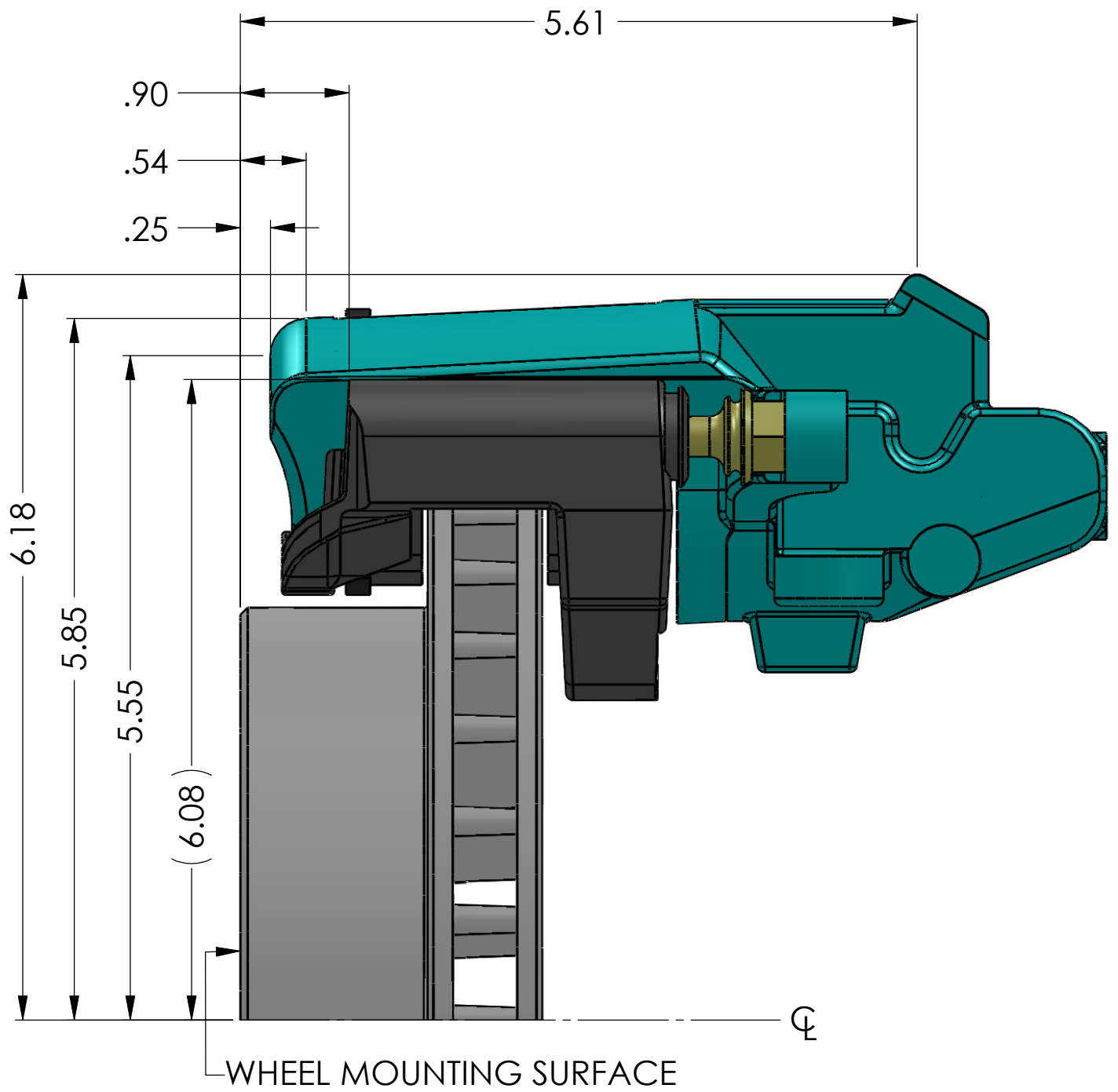

DIMENSIONS ARE IN INCHES

TEMPLATE NO.
T-038

DO NOT SCALE
DRAWING

REV
-

SSBC

STAINLESS STEEL BRAKE CORP.

CLARENCE, NEW YORK 14031-1720
Ph: 716-759-8666 / 800-448-7722 ~ Fx: 716-759-8688
WWW.SSBRAKES.COM