

AIR LIFT
PERFORMANCE

USER GUIDE



ALP4TM

**Air Management
System**

Unlock the full potential of your ALP4 System

With mobile app integration, ALP4 lets you use and fine-tune your setup from anywhere, ensuring ultimate control whether you're at the show or on the street.

Scan the QR Code to download the mobile app.



See page 20 for instructions on pairing your device.

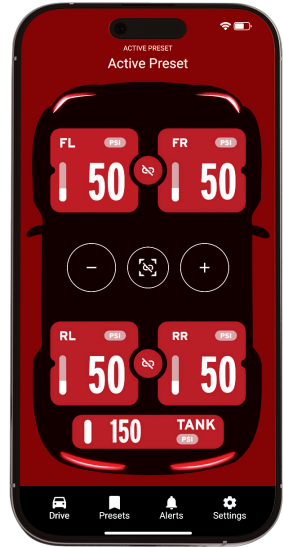

CONTENTS

Notation Explanation	4
Important Safety Notices	4
Introduction	5
Controller Overview	5
First Time Setup	6
Calibration	6
User Interface	8
Settings Quick Reference Guide	10
Display Settings	11
System Faults Table	12
Operation Settings	14
Sensor Tool (Height mode only)	16
Height Sensor Orientations	17
Compressor Settings	18
Location Settings	19
Button Configuration	19
Factory Reset	20
Firmware Updates	20
Compressor Specifications	20
Integrated Diagnostics	21
Warranty Information	22

Notation Explanation

Hazard notations appear in various locations in this publication. Information that is highlighted by one of these notations must be observed to help minimize risk of personal injury or possible improper installation, which may render the vehicle unsafe. Notes are used to help emphasize areas of procedural importance and provide helpful suggestions. The following definitions explain the use of these notations as they appear throughout this guide.

**DANGER**

INDICATES IMMEDIATE HAZARDS WHICH WILL RESULT IN SEVERE PERSONAL INJURY OR DEATH.

**WARNING**

INDICATES HAZARDS OR UNSAFE PRACTICES WHICH COULD RESULT IN SEVERE PERSONAL INJURY OR DEATH.

**CAUTION**

INDICATES HAZARDS OR UNSAFE PRACTICES WHICH COULD RESULT IN DAMAGE TO THE MACHINE OR MINOR PERSONAL INJURY.

Important Safety Notices

**WARNING**

Before servicing the vehicle, make sure to turn off "Rise-On-Start" and "Preset Maintain." This will eliminate any unintended suspension cycling if you need to turn the key on in the vehicle for any reason.

**WARNING**

Only use the ALP4 App on a mobile device when the vehicle is in a clear line of sight. To avoid the risk of serious injury or harm, verify that no person or thing is near or in the way of the vehicle's path of travel while cycling the suspension.

**WARNING**

For user safety and to prevent vehicle damage, the system has a 25% or 25psi (1.7bar) minimum drive height as the default. Due to extreme risk of danger to the user or vehicle, Air Lift Company strongly recommends not to change this value. If, for some reason, the minimum drive height is set below the default value, Air Lift Company suggests this setting only be used while the vehicle is stationary. It is possible to set the vehicle at a height that is below this threshold, then start driving. This is a universal system and settings will be different for every user and vehicle. The installer is responsible to determine how low the suspension can be set without causing damage. It is the sole responsibility of the user, and Air Lift Company will not be held liable for anything that may happen to the operator or the vehicle as a result of the user's choice to alter these default values below recommended minimums.

**WARNING**

Floor jacks can be dangerous. When using a floor jack, make sure it is rated for the load it is lifting. Check the vehicle owner's manual for information about where to place the jack. Before raising the vehicle, place wheel chocks in front and behind the wheels to prevent them from rolling. Always use jack stands to support the vehicle. Never get under or place any body parts under a vehicle that is solely supported by the jack.

Introduction

This Guide is intended to assist with the initial setup and calibration of an ALP4 system. Ensure that the ALP4 system is installed as instructed per the ALP4 Installation Guide before attempting a system calibration.

Read this entire User Guide before beginning calibration or performing any maintenance, service or repair. The information includes a step-by-step calibration set-up, display options and functions, and diagnostic troubleshooting.

Air Lift Company reserves the right to make changes and improvements to its ALP4 products and publications at any time. For the latest version of this User Guide, contact Air Lift Company at (800) 248-0892 or visit www.airliftperformance.com.

Controller Overview



Physical Button default settings are noted above, but are user configurable. See page 19 for details.

Note: Representative screen images are used throughout this User Guide.

First Time Setup

This section is intended to assist with the initial setup and calibration of an ALP4 system. Ensure that the ALP4 system is installed as instructed per the ALP4 Installation Guide (MN-1209) before attempting a system calibration.

Calibration

Upon starting the ALP4 manifold for the first time, the system will prompt the user to complete calibration. Calibration must be completed to be able to use presets with the system.

NOTE: *If you purchased height sensors with your ALP4 kit, please reference the Height Sensor Installation Guide (MN-947) and the height sensor tool section of this guide before proceeding with calibration (page 16). It is necessary to verify proper height sensor range using the height sensor tool before performing height calibration.*

**DANGER**

THE ALP4 SYSTEM WILL MAKE AUTOMATIC ADJUSTMENTS DURING CALIBRATION, WHICH MAY LOWER THE VEHICLE'S FRAME TO THE GROUND. ENSURE THAT ALL PERSONS AND OBJECTS ARE CLEAR FROM THE VEHICLE WHEN CALIBRATING THE SYSTEM.

CALIBRATION WIZARD

1. Make sure the vehicle is on a level surface and select "Yes."
2. Verify that the front wheels are straight to prevent damage to the fenders, then select "Yes."
3. Verify nothing is under the vehicle, then select "Yes".
4. Verify that the manifold is securely mounted in a proper orientation, then select "Yes."
5. Determine how many compressors are in use. If using a single compressor, select one. If using two compressors (second compressor harness required), select two.
6. If height sensors are installed, select "Yes." If running as a pressure-only system, select "No."
7. Choose whether to calibrate them automatically or manually. Most vehicles may be calibrated automatically. The manual option should be used when there is a custom setup where there may be concern about component interference at either high or low limits.

8. After selecting “Yes,” the system will begin calibration. Selecting “No” will exit the calibration wizard.
9. The system checks to make sure the manifold is mounted in a proper orientation.
10. System is calibrating the accelerometer.

NOTE: *After step 10, use manual controls to set the desired pressure limits for the system. When setting a lower limit, air out the vehicle’s suspension to the minimum desired travel. When setting an upper limit, air up the vehicle’s suspension to the maximum desired travel. After setting these parameters, the system will proceed through the rest of calibration.*

11. System is now calibrating the front axle for pressure mode.
12. System is now calibrating the rear axle for pressure mode. If using the system for pressure only, calibration will complete after this step.
13. Height Sensor Calibration (upper limits)
 - a. If Auto Sensor Calibration was selected, the system will cycle the suspension to calibrate its upper limit position.
 - b. If Manual Calibration was selected, the system will now ask for the user to set the upper height limits. Do this by using manual controls to raise the suspension to its highest desired setting on all four corners.
14. Height Sensor Calibration (lower limits)
 - a. If Auto Sensor Calibration was selected, the system will now cycle the suspension to calibrate its lower limit position.
 - b. If Manual Calibration was selected, the system will now ask for the user to set the lower height limits. Do this by using manual controls to raise the suspension to its lowest desired setting on all four corners.
15. The system will now check Height Sensor vehicle wiring (Only completes this if the user selected automatic height calibration).
16. The system will now perform movement calibration for height mode.
17. Once the system has run through the calibration wizard successfully, the system is ready for use.

NOTE: *If calibration fails, reference page 12 for calibration message explanations. Many calibration failures can occur due to improper system installation. Reference the ALP4 installation guide or the height sensor installation guide for more information.*

NOTE: *The ALP4 system should be recalibrated if the max tank pressure is changed after calibration.*

User Interface

The ALP4 controller has five distinct menus for monitoring and adjusting system parameters.

1. DRIVE MENU

The drive menu (Fig. 1) includes detailed information about the pressures/heights of each corner, tank pressure, compressor status, and preset mode. This menu is view-only and is intended to report system information to the user.

Air Spring Key
FL - Front Left
FR - Front Right
RL - Rear Left
RR - Rear Right

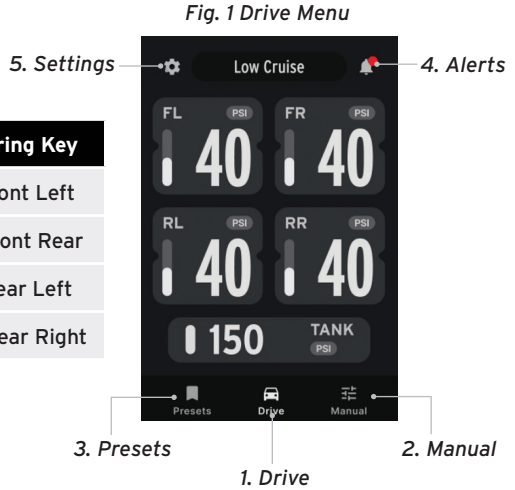

2. MANUAL MENU

The manual menu (Fig. 2) allows the user to select any combination of air springs and manually adjust them using the + and - buttons. Selected air springs will appear as highlighted on the display.

NOTE: Making a manual adjustment will put the manifold in manual mode. While in manual mode, the system will not attempt to maintain presets until a preset is activated again.

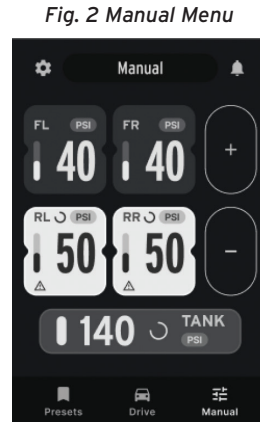

WARNING

THE SYSTEM WILL NOT ACTIVELY MAINTAIN MINIMUM DRIVE HEIGHT IN MANUAL MODE. TO PREVENT DAMAGE OR INJURY, MAKE MANUAL ADJUSTMENTS ONLY WHEN PARKED.

3. PRESETS MENU

The presets menu (Fig. 3) allows the user to edit and activate presets. Select the pencil tool to edit a preset, and left/right swipe to access all saved presets. The system comes with three default presets which may be reconfigured. A maximum of 5 presets in total may be saved.

Height Default Presets	Pressure Default Presets
Preset Low - 25%	Preset Low - 25psi/1.72bar
Preset Ride - 50%	Preset Ride - 50psi/3.44bar
Preset High - 75%	Preset High - 75psi/5.17bar

Fig. 3 Presets Menu

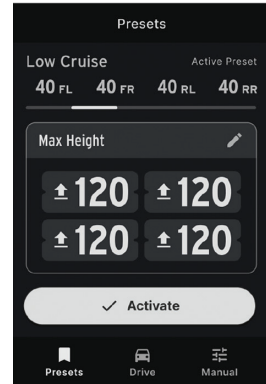

NOTE: Some settings change how presets work. See the operation settings section (page 14) for details on settings that may impact preset operations.

4. ALERTS MENU

The alerts menu will display faults and other system messages. Select any alert for an expanded window with more information.

Fig. 4 Alerts Menu

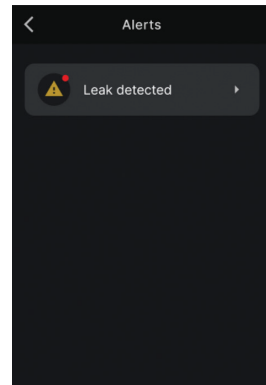

5. SETTINGS

See page 10 for the Settings Quick Reference Guide.

Settings Quick Reference Guide

Category	Setting	Default	Range/Options
Display	Brightness	70%	0%-100%
	Auto Brightness	Off	On, Off
	Display Color	Default (White)	-
	ECU Color	Red	-
	ECU Brightness	70%	0%-100%
	Display Sleep Timer	10s	Off, 2, 5, 10 min
	Display Sleep Brightness	40%	0%-100%
	Display Orientation	Normal	Normal, Buttons Right, Buttons Left
Operation	Rise-On-Start	Off	On, Off
	Preset Maintain	On	On, Off
	Front Min Drive Pressure/Height	25psi/25%	0-100psi, 0-100%
	Rear Min Drive Pressure/Height	25psi/25%	0-100psi, 0-100%
	Pressure/Height mode	Pressure	Pressure, Height
	Axle Equalization/ Anti Cross-Load	On	On, Off
	Phone Pairing	Off	On, Off
	Double Tap/Single Tap	Double Tap	Double Tap, Single Tap
	Slow Lift Range	Off	On, Off
	Adjustable Pulse Rate	Medium	High, Medium, Low
	Valet Mode	Off	On, Off
	Accuracy Modes	Medium	High, Medium, Low
Show Mode	Off	On, Off	
Standby Mode	.5 hr	Off, .5-24 hrs	
Sensor Tool	-	-	See page 16
Compressor	Enabled/Disabled	Enabled	Enabled, Disabled
	Manual Control	Off	On, Off
	Compressor Count	Single	Single, Dual
	Maximum Pressure	150psi/10342mbar	150-200psi, 10342-13790mbar
	Minimum Battery Voltage	11V	10-15V
	Duty Cycle	50%	33%, 50%, 66%, 75%, 100%
	Compressor Crank Offset	10s	5s-30s
Compressor Performance Testing	-	-	
Location	Units	psi	psi, bar
	Language	English	English, Spanish, German, French
Button Configuration	Button 1	All Down	See page 19
	Button 2	Preset 1	See page 19
	Button 3	Preset 2	See page 19
	Button 4	All Up	See page 19
Factory Reset	-	-	See page 20
About and Support	-	-	-

Display Settings

BRIGHTNESS

0-100% - Set the brightness for the display while in use.

AUTO BRIGHTNESS

On/Off - Allows the display to determine screen brightness automatically.

DISPLAY COLOR

Select the display's background and foreground color.

ECU COLOR

Select the manifold's LED color.

ECU BRIGHTNESS

0-100% - Set the brightness for the manifold LEDs.

DISPLAY SLEEP TIMER

Off, 2, 5, 10 minutes - Amount of time elapsed before the display will dim.

DISPLAY SLEEP BRIGHTNESS

0-100% - Display sleep screen brightness.

DISPLAY ORIENTATION

Normal, Buttons Right, Buttons Left - Select the orientation of the display (restart required).



Fig. 5 Normal Orientation



Fig. 6
Buttons Left



Fig. 7
Buttons Right

Representative screen images

System Faults	Fault Descriptions
Height Sensor Limit	This fault occurs when the height sensor travel exceeds the 120° limit, or the sensor voltage is too low or too high.
Height Sensor Not Present	This fault occurs when one or more height sensors are not detected due to a loose or broken connection, broken sensor, or similar.
Pressure Sensor	This fault occurs when a pressure sensor inside of the manifold has failed, or a sensor is overpressured.
Min Height Reached	This fault occurs when the set Minimum Ride Height limit has been reached. Wait for the vehicle to come to a complete stop to lower below limit. The limit can be adjusted in the settings via the display or app.
Compressor Fault	This fault occurs when the system is attempting to inflate the tank with the compressor, but the tank is not seeing a 6psi increase after 120 seconds. This indicates a weak or faulty compressor, check valve issue, or a tank leak.
Compressor Overrun	The fault occurs when the compressor has been running for the max duty cycle for 15 minutes (default setting). This can be adjusted via the settings in the display or app.
Tank Too Low	This fault occurs when the tank pressure falls below 80psi (5.5 bar) for at least 5 seconds while trying to increase air spring pressure.
Improper Manifold Mount	This fault occurs when the manifold is mounted in an unacceptable orientation as outlined in the User Guide. An improper mounting orientation will prevent calibration.
Voltage High	This fault occurs when the voltage at the manifold is at or above 16V, indicating an over-voltage from the vehicle's electrical system.
Voltage Low	This fault occurs when the voltage at the manifold is at or below 11V (default setting). This fault disables compressor operation, as to not drain the vehicle's battery. The minimum voltage can be adjusted via the settings in the display or app.
Leak Detected	This fault occurs when an air spring pressure has dropped 10psi over 5 minutes with Preset Maintain turned off; or when the system has made 5 automatic inflation adjustments within 5 minutes with Preset Maintain turned on.
Height Range Error	This fault occurs when the height sensor's total range is under 35° for at least one sensor, requiring readjustment. Use the height sensor tool to see the limits and make adjustments.
Wireless Connection Error	This fault occurs when the device has lost connection and is unable to reconnect to the manifold. Verify manifold is in range, powered on, and available to connect.
Firmware Update Required	This fault occurs when the manifold and display have incompatible software versions on them.
Factory Calibration Error	This fault occurs when the manifold is missing the factory calibration.
Compressor Performance	This fault occurs when the compressor efficiency is at or below 70% after going through a compressor test. This can detect a weak or failing compressor early.
Parking Brake Reverse Wired (For Australia only)	This fault occurs when the system detects 12V power instead of ground on the parking brake wire, indicating an improper connection. This wire must be connected to ground.
Calibration Faults	Fault Descriptions
Height Calibration Fail	This fault occurs when the Height Calibration has failed due to a wiring, range or limit error, sensor failure, or failed to achieve target height.
Height Calibration Limit	This fault occurs when the Height Calibration has failed due to a height sensor going out of the acceptable range, whether minimum or maximum.
Mount Calibration Fail	This fault occurs when the manifold is mounted in an unacceptable orientation during calibration or when mounting calibration has not been completed.
Calibration Invalid	This fault occurs when the system has not been calibrated, and there is an attempt to use height or pressure preset.
Waiting For Tank to Fill	This occurs when the tank pressure has reached 15psi (1 bar) below the max pressure during calibration, and the compressor is refilling the tank.
Wiring Error	This fault occurs when two or more height sensors are incorrectly connected to the system, such as criss-crossed connections.
Pressure Calibration Fail	This fault occurs when the pressure calibration has failed due to failure to hit the target pressures.

Resolution/Troubleshooting

Use the height sensor tool within the display or app to correctly adjust the height sensors, ensuring the height sensor is within the appropriate ranges both at minimum and maximum.

Double-check that all height sensor connections are secure. Check height sensors and wire harnesses for damage.

Ensure that all pressure inputs are less than 200psi (13.79 bar). If the fault persists, try airing out the system and then disconnecting the manifold from all air connections. Power cycle the manifold. If the fault still persists, then contact customer service (800-248-0892).

This may be adjusted to a different value to suit the user's needs.

Most likely caused by a leaking check valve, but could be caused by a leak anywhere in the system between the compressor(s) and manifold. Ensure that all plumbing is secure (all PTCs are fully connected, all threaded fittings connected properly, etc.). Use the soapy water test if no obvious leaks are evident. If everything checks out with no leaks, it could indicate a faulty or weak compressor.

The compressor should be allowed to cool for 15 minutes, assuming a 50% duty cycle. The fault should self-clear once the necessary amount of time has passed for its respective duty cycle.

Allow the tank system sufficient time to fill for the fault to clear.

Reference the manifold installation guide for information on acceptable mounting orientations. Restart calibration once the manifold has been properly reoriented to clear the fault.

Connect the manifold to a power source below 16V.

This may indicate a weak vehicle battery. This value may be adjusted to a different value to suit the user's needs.

Ensure that all plumbing is secure (all PTCs are fully connected, all fittings connected properly, etc.). Use the soapy water test if no obvious leaks are evident.

Use the height sensor tool to identify the necessary height sensor ranges and reorient the sensors to meet the range requirements.

Verify manifold is in range, powered on, and available to connect. If the problem persists, then try performing a mobile operating system update, delete and re-download the app, and also cycle power to the manifold.

Using the app, install any available firmware to the display and manifold.

If this fault is present, please contact customer service (800-248-0892).

It is recommended to replace the compressor(s) that are below 70% efficient. For the most accurate results, ensure that there are no leaks in the system before performing this test.

Connect wire to ground instead of a positive voltage source. This may be verified using a multimeter.

Resolution/Troubleshooting

Verify height range and limits using the height sensor tool. Re-run calibration.

Verify height limits are within the appropriate range using the height sensor tool within the mobile app or display.

Reference the manifold installation guide for information on acceptable mounting orientations. Restart calibration once the manifold has been properly reoriented to clear the fault.

Calibrate the system prior to attempting to use presets.

Allow system sufficient time to fill for the fault to clear.

Verify height sensor labels and connections.

Attempt to re-calibrate the system with different max/min parameters. Min limit should be as close to the ground as possible without touching and the max limit should be as high as the vehicle's suspension allows for travel.

Operation Settings

RISE ON START

On/Off - This setting brings the vehicle to ride height at key-on if at a preset below ride height.

PRESET MAINTAIN

On/Off - When enabled, the system will actively maintain the selected preset, whether pressure or height.

FRONT AXLE MINIMUM DRIVE HEIGHT

0-100psi/0-100% - Set the minimum front axle ride height. The system will not deflate below this level while driving.

REAR AXLE MINIMUM DRIVE HEIGHT

0-100psi/0-100% - Set the minimum rear axle ride height. The system will not deflate below this level while driving.



WARNING

TO PREVENT DAMAGE OR SERIOUS INJURY, ENSURE THAT MINIMUM DRIVE HEIGHT IS APPROPRIATELY TUNED TO THE INSTALLATION VEHICLE SO THAT IT MAY NOT TOUCH THE GROUND WHILE DRIVING.

PRESSURE/HEIGHT MODE

Set the system to operate in pressure mode or height mode.

AXLE EQUALIZATION/ANTI-CROSS LOAD

On/Off - Pressure mode: Prevents the system from having presets per corner that are too far off from one another. Height mode: Prevents a height setting that results in severe axle cross-loading.

PHONE PAIRING

On/Off - Toggle on to allow the manifold to pair with mobile devices (see page 20 for alternative pairing modes).

DOUBLE TAP/SINGLE TAP

Choose whether a double press or single press is required to activate a preset.



WARNING

ENABLING SINGLE TAP WILL MAKE THE SYSTEM VERY RESPONSIVE AND MAY CAUSE UNINTENTIONAL ADJUSTMENTS.

SLOW LIFT RANGE

On/Off - When activated, the system will always use slow fill and slow dump under minimum drive pressure or minimum drive height. This means the system will have more controlled movements when very close to the ground.

ADJUSTABLE PULSE RATE

High, Medium, Low - Adjusts valve on/off times for slow fill and slow exhaust. Lower pulse rates are recommended in high-pressure, high-flow systems.

VALET MODE

On/Off - The system display will enter a “read only” mode. This setting may be disabled via the app or by power cycling the manifold.

ACCURACY MODES

High, Medium, Low - Adjusts the tolerances for achieving presets. Lower accuracy settings may decrease time needed to achieve presets.

SHOW MODE

On/Off - When activated, this will allow for full system functionality and user operation following ignition is turned off once.

STANDBY MODE

Off, .5-24 hrs - Choose the duration that the manifold will enter a low power state before shutting down entirely. During standby mode, the manifold will connect to mobile devices, but the display and compressors are disabled.

Sensor Tool (Height mode only)

When installing height sensors with an ALP4 system, it is strongly recommended to use the height sensor tool prior to calibrating the system.

Access the Height Sensor Tool through the Settings Menu in the Controller and on the Air Lift Performance ALP4 app.

NOTE: Reference the height sensor installation guide to determine mounting location for each sensor. Once each sensor's mounting location has been identified, the height sensor tool may be used to fine-tune their position, angle, and armature/linkage connections, ensuring the proper sensor range is achieved.

HOW IT WORKS:

- Upon opening the height sensor tool, all four sensors will display 'Range Low' until each armature has moved at least 35° from its respective starting position. The sensor tool will show a checkmark next to each corner that satisfies the minimum range requirement (Fig. 8).
- If the display shows a double arrow symbol when actuating an armature (Fig. 9), then a sensor armature has actuated past a safe operating angle and the sensor mounting location/angle should be readjusted so that cycling the suspension no longer results in a sensor limit error. Each height sensor has 120° of allowable travel between the high limit and low limit.
- If a sensor is not connected, then the sensor tool will read "Sensor Not Found."
- With the sensors mounted, actuate the suspension to its highest and lowest points to verify that no sensor hits a sensor limit and also verify that minimum range for all sensors has been met before attempting to calibrate the system.

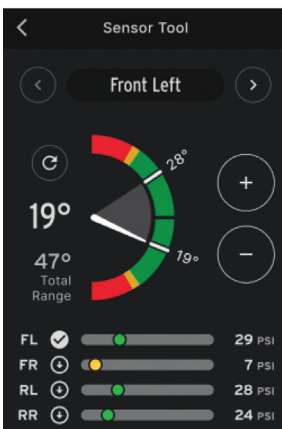

Fig. 8 Example of a corner (FL) that meets the minimum range requirement

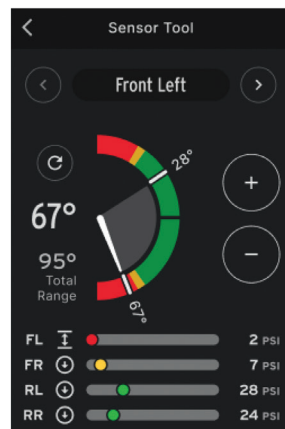
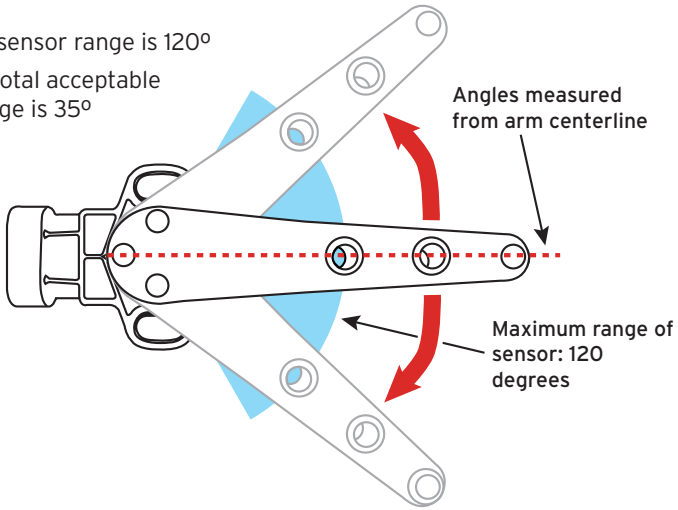

Fig. 9 Example of a corner (FL) that exceeds the allowed operating range

Height Sensor Orientations

Maximum sensor range is 120°

Minimum total acceptable sensor range is 35°



Preferred orientations (A., B.)

A.

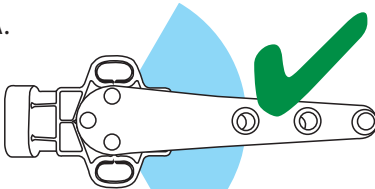

B.

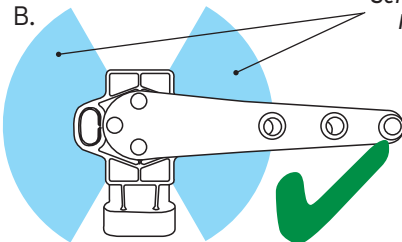

Sensor Arm Range

Acceptable orientation (C.)

C.

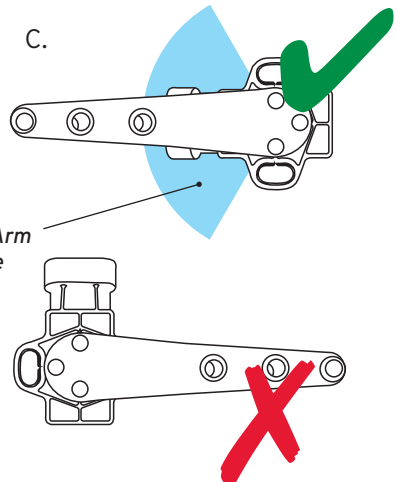

Compressor Settings

ENABLED/DISABLED

Toggle whether the system will automatically control connected compressor(s).

MANUAL CONTROL

On/Off - Toggle connected compressor(s) on or off.

COMPRESSOR COUNT

Single/Dual - Select the number of compressors connected to the system.

MAXIMUM PRESSURE

150-200psi/10342-13790mbar - Set the minimum rear axle ride height. The system will not deflate below this level while driving.

NOTE: *An ALP4 system should be recalibrated if the max tank pressure is changed after calibration.*

MINIMUM BATTERY VOLTAGE

10-15V - Set the minimum battery voltage required for compressor operation.

DUTY CYCLE

33%, 50%, 66%, 75%, 100% - Select the duty cycle for the compressor(s).



CAUTION

SETTING THE DUTY CYCLE HIGHER THAN THE MANUFACTURER'S RECOMMENDED VALUE MAY CAUSE DAMAGE TO THE COMPRESSOR(S).

COMPRESSOR CRANK OFFSET

5s to 30s - The duration that the system must wait after ignition before activating compressors.

COMPRESSOR PERFORMANCE TESTING

Run this test to determine the efficiency of the compressor(s).

Location Settings

UNITS

Select psi or bar.

LANGUAGE

Select English, Spanish, French or German.

Button Configuration

The ALP4 display has four physical buttons in addition to its touchscreen controls. These buttons may be remapped in the display settings to perform preferred actions.

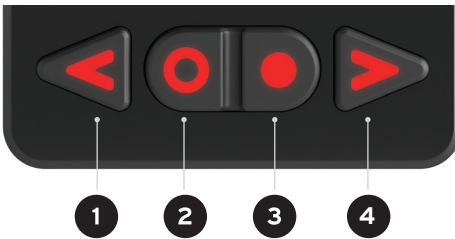

Button Default Configurations:

- Button ① - All Down
- Button ② - Preset 1
- Button ③ - Preset 2
- Button ④ - All Up

Button Options:

- Front Up
- Rear Up
- Rear Down
- All Up
- All Down
- Preset 1
- Preset 2
- Preset 3
- Preset 4
- Preset 5
- Air Out

Factory Reset

Use factory reset to clear calibration data and reset all settings to factory defaults.

Firmware Updates

To update the ALP4 manifold or display, first download the Air Lift Performance ALP4 app to a mobile device. The app may be downloaded for free via the Apple App Store or the Google Play Store. Then, enable pairing mode on the manifold and connect to the manifold using the app.

Pairing mode may be enabled through the operation settings on the display. If no display is present, then turning the ignition on for 3 seconds, off for 3 seconds, and then back on again will enable pairing mode for one ignition cycle.

Once the devices are paired, go into the settings on the app, select "About & Support," and select firmware update option.

Compressor Specifications

Compressor Type	Max Working Pressure	Duty Cycle @ Rated Pressure
380C	200psi (13.8bar)	55% @ 200psi (13.8bar)
410	200psi (13.8bar)	50% @ 200psi (13.8bar)
444C	200psi (13.8bar)	50% @ 200psi (13.8bar)
480C	200psi (13.8bar)	50% @ 200psi (13.8bar)
485C	200psi (13.8bar)	100% @ 200psi (13.8bar)

Integrated Diagnostics

The ALP4 air management system has an integrated diagnostics tool that can be used to validate a system install or troubleshoot potential system issues. The manifold will only perform the diagnostic routine if ignition is on prior to a battery connection to the manifold. The FL valve will generate a series of clicks separated by a pause, which indicates either a pass code or an error code. Count the number of clicks before and after the pause, and use the table below to decipher the code.

1. Ensure that ignition is ON.
2. Turn Rise-On-Start and Preset Maintain OFF.
3. Air out the vehicle and disconnect the FL air line from the manifold.
4. With ignition still on, disconnect and reconnect the manifold electrical connector.



WARNING

BEFORE SERVICING THE VEHICLE, MAKE SURE TO TURN OFF "RISE-ON-START" AND "PRESET MAINTAIN." THIS WILL ELIMINATE ANY UNINTENDED SUSPENSION CYCLING IF YOU NEED TO TURN THE KEY ON IN THE VEHICLE FOR ANY REASON.

Code	Description
No Clicks	Poor battery or ignition harness connection
Pass code 1-1	Manifold is functioning properly. Battery and ignition harness connection are OK.
Error code 2-1	Manifold 5V Display Supply Error
Error code 2-2	Manifold 5V Height Sensor Supply Error
Error code 2-3	Manifold 3.3V Pressure Sensor Supply Error
Error code 2-4	System Battery Voltage Low (below 9V)
Error code 2-5	Manifold Solenoid Over-Current Detected
Error code 3-1	Manifold FL Solenoid Failure
Error code 3-2	Manifold FR Solenoid Failure
Error code 3-3	Manifold RL Solenoid Failure
Error code 3-4	Manifold RR Solenoid Failure
Error code 3-5	Manifold Tank Solenoid Failure
Error code 3-6	Manifold Exhaust Solenoid Failure

Limited Warranty and Return Policy

Air Lift Company provides a Limited Warranty to the original purchaser of Air Lift Performance products from the date of original purchase, that the products will be free from defects in workmanship and materials when used on cars and trucks as specified by Air Lift Company and under normal operating conditions, subject to the requirements and exclusions set forth in the full Limited Warranty and Return Policy.

Full Limited Warranty and Return Policy are available at:
www.airliftperformance.com/support/warranty and are subject to change.

Warranty Registration & Claims

To register your warranty, please visit:
www.airliftperformance.com/support/warranty-registration

To submit a warranty claim, please visit:
www.airliftperformance.com/support/submit-warranty-claim

Need Help?

Contact our customer service department by calling (800) 248-0892. For calls from outside the USA or Canada, dial: 1 (517) 322-2144.



*Thank you for purchasing
Air Lift Performance products!*

Air Lift Performance • 2727 Snow Road • Lansing, MI 48917
or P.O. Box 80167 • Lansing, MI 48908-0167
Toll Free (800) 248-0892 • Overseas (517) 322-2144
Fax (517) 322-0240 • www.airliftperformance.com

Printed in the USA
JPR-0525



MADE IN USA
WITH GLOBAL
COMPONENTS