



# INSTALLATION INSTRUCTIONS

PERFORMANCE AT THE WHEELS KIT W120

1964-1/2 - 69 Ford & Mercury

---

Thank you for choosing STAINLESS STEEL BRAKES CORPORATION for your braking needs. Please take the time to read and carefully follow these instructions to insure the ease of your installation as well as the proper performance of the complete system.

Before beginning your installation, please verify you have received all the parts indicated on the packing slip. If you believe anything to be missing or incorrect, please call our Customer Service Department at 716-759-8666.

To assure your installation will go safely and smoothly, have the following items on hand to assist you:

**JACK & JACK STANDS**  
**TORQUE WRENCH**  
**TUBE WRENCHES**  
**MALLET**  
**WHEEL BEARING GREASE**

**LUG WRENCH**  
**SOCKET SET**  
**WRENCH SET**  
**BRAKE FLUID**  
**BRAKE CLEANER**

**This kit uses the following pads:**

**SSBC#: A1033**

**FMSI#: D-11**

Revision 3 3/5/12



***THIS KIT IS DESIGNED FOR CARS WITH V-8 SPINDLES (5-LUG WHEELS) ONLY AND WILL NOT FIT CARS WITH 6 CYLINDER (4-LUG WHEELS) SPINDLES.***

***TIP: BEFORE BEGINNING INSTALLATION, SPRAY ALL FITTINGS AND FASTENERS WITH PENETRATING OIL.***

### **Front Drum Brake Removal**

- 1) Raise the car until the wheels and tires clear the floor and support the car on jack stands. Remove the wheel covers or hub caps and remove the wheel and tire assemblies from the drums.
- 2) Remove the grease cap from the hub. Remove the cotter pin, nut lock, adjusting nut, and flat washer from the spindle. Remove the outer bearing.
- 3) Pull the hub and drum assembly from the spindle. If the brake drum will not come off easily, retract shoes by inserting a narrow screwdriver through the brake adjusting slot in the backing plate and disengage the adjusting lever from the adjusting screw. While holding the adjusting lever away from the adjusting screw, back off the adjuster.
- 4) Drain system of all the brake fluid as follows:
  - a) Remove master cylinder cover. Use a syringe to remove as much fluid from the master cylinder reservoir as possible.
  - b) Attach hoses to front bleeder screws and place other end of hose in a container. Open bleeder screw.



***BE CAREFUL NOT TO GET BRAKE FLUID ON THE PAINT. IT CAN CAUSE SEVERE DAMAGE!!***

- c) When fluid stops draining, disconnect the flexible hoses from the rigid brake line at the frame and remove horseshoe clips. Use plenty of penetrating oil between the tube nut and the mating fitting. We strongly recommend the use of a tube wrench available from any tool supply store including Sears.
- 5) Remove drum brake as follows:
  - a) Remove flexible hose from the back of both brake cylinders and remove brake cylinder.
  - b) Remove entire drum brake assembly as a unit by removing the four (4) bolts attaching the backing plate to the spindle flange. Discard assembly.
- 6) Installation of Conversion kit (refer to Figure I)
  - a) Install caliper mounting bracket followed by rotor splash shield (over gasket, if there) on spindle. Make sure mounting bracket bosses face toward inside of car and bracket and shield are for the correct side of car (marked left or right).  
NOTE: Calipers will mount towards front of car.
  - b) Attach shield and bracket to spindle with grade 8 bolts supplied in kit from the outside in so the head of the bolt is on the outside. Secure with locknuts and torque to 35-45 ft./lbs.
- 7) Rotors and Bearings (refer to figure II)
  - a) Remove the protective coating from the new rotor with brake cleaner (available at most parts stores).
  - b) Pack the inner (larger) bearing with wheel bearing grease, and place in inner cup (which is already in the rotor assembly). Pack grease lightly between the

lips of the grease seal and then install seal. Use a soft mallet or a piece of wood so as not to distort the seal.

- c) Install the rotor and hub assembly on the spindle.
- d) Pack and install the outer wheel bearing, washer and adjusting nut.
- e) The wheel bearing adjustment as follows is especially important with disc brakes: Rotate rotor while torquing spindle nut to 17-25 ft.-lbs. Back off the adjusting nut 1/2 turn and retighten to 10-15 in.-lbs. Selectively position nut retainer on adjusting nut so that a set of slots are in line with the cotter pin hole. Adjusting nut should not be rotated during this operation. Lock adjusting nut and retainer with cotter pin and install grease cap.



**FOR THE BALANCE OF THESE INSTRUCTIONS, BE CAREFUL THAT ALL HYDRAULIC COMPONENTS ARE KEPT CLEAN AND FREE OF DEBRIS INSIDE AND OUT. REMEMBER; DIRT IS THE ENEMY OF HYDRAULIC SYSTEMS, AND WE WILL NOT BE RESPONSIBLE FOR SYSTEM FAILURES DUE TO AN UNCLEAN NSTALLATION !**

8) Caliper Installation

- a) Place pads in caliper (lining material should face each other).
- b) Install stainless steel pad retaining splash shield and secure the shield to the caliper with the stainless retaining bolts and lock washers supplied. Torque bolts to 7-11 ft./lbs.
- c) Connect flexible brake lines to the caliper with one (1) copper washer between the hose fitting and the caliper.
- d) Slide caliper over rotor and install the caliper mounting bolts and torque to 45-60 ft/lbs. Check to insure that the rotor runs squarely and centrally between the two bosses of the caliper. There should also be approximately 0.090-0.120 inch clearance between the caliper body and the rotor outside diameter. Make sure bleeder screws point up.



***IF CALIPER DOES NOT SLIDE EASILY INTO PLACE OR DOES NOT LINE UP CORRECTLY WITH MOUNTING BRACKET, MINOR TRIMMING OF THE SPLASH SHIELD MAY BE REQUIRED. IF TRIMMING IS REQUIRED, IT SHOULD ONLY BE DONE ON THE TWO EDGES OF THE SHIELD THAT ARE ADJACENT TO THE CALIPERS.***

- e) Attach caliper flex line to frame (12 point bracket) and push horseshoe clip over end of hose to retain it.
- f) With both front wheels off the ground, turn wheels through a full left to right turn to insure that the hoses do not twist or take a double bend. If hoses do not bend correctly, remove them from the 12 point bracket and reorient them so that they bend with a minimum of twisting. Failure to complete this part of the installation may cause brake lockup in service since the thin wall interior hose may collapse and restrict the fluid from relieving caliper line pressure when the brake pedal is released.

- 9) To insure the proper function of your SSBC brake system several other parts will be required to complete the installation. If you did not purchase these parts at the same time as your brake kit they can be ordered from SSBC or your distributor. If you choose to source your own parts please keep the following points in mind.
- a) **Master Cylinder**  
A master cylinder designed for disc brake applications must be used. Be sure the depth of the piston is correct for the pushrod length you are using. For manual brake applications a bore size of 15/16"-1" is needed. For power applications a 1" bore size will work correctly.
  - b) **Power Booster**  
The vehicle must have a minimum of 16" of vacuum at idle for the booster to work properly. If you do not have 16"Hg you will need a vacuum pump or you will have to run a non power system. There are several different booster assemblies available for 1960's-70's Ford vehicles. Factors such as year, transmission, and engine size all determine which booster will fit your specific vehicle. In addition some vehicles will need a new pedal assembly and/or a pedal support bracket. With these factors in mind SSBC strongly recommends that you contact us directly or one of our distributors to select the proper parts your installation.
  - c) **Proportioning Valve**  
Installation of a proportioning valve will be necessary to insure the rear brakes do not lock up prematurely causing a loss of control. This is necessary due to the increased pressure generated by the disc brake master cylinder. SSBC recommends an adjustable proportioning valve to allow fine tuning of the proper rear brake pressure for your specific vehicle.
  - d) **Brake Line Connection**  
All brake lines should be steel or stainless steel tubing. All flares should be SAE Inverted double flares. For some applications little or no plumbing changes will be necessary while others will require all new lines from the frame rail up to the master cylinder. Be sure all lines take smooth bends avoiding kinks or restrictions in the lines. Be sure to connect the brakes to the proper reservoir of the master cylinder. For GM cars the reservoir closest to the firewall usually feeds the rear brakes, while on most Ford and Mopar vehicles that reservoir feeds the front brakes. If you are using an aftermarket master cylinder check with the manufacturer for proper connections.
- 10) **Filling and Bleeding system**
- a) It is advisable to replace the brake fluid if the color is brown or muddy. This is due to water that has been absorbed by the fluid which will eventually corrode the brake lines and master cylinder. This absorbed moisture can also cause a vapor lock situation under extreme braking conditions. Flush system with clean brake fluid and replace with a good grade of disc brake fluid. DOT 3 or DOT 4 fluids are acceptable.
  - b) The simplest and most effective way to bleed your brakes is to use the gravity bleeding approach as follows:
    - 1) With calipers installed, make sure all fittings are tight and master cylinder is topped off.
    - 2) Open one bleeder screw at a time starting at the wheel farthest from the

master cylinder and working your way back around the wheel closest to the master. With bleeder screw open, observe bleeder. At first the fluid will begin to escape with intermittent air bubbles. When the air bubbles stop and a steady flow of fluid is observed for several seconds, close the bleeder valve and move on to the next wheel.



**MAKE SURE TO KEEP A CLOSE WATCH OVER THE FLUID LEVEL INSIDE THE MASTER CYLINDER DURING THE BLEEDING PROCESS. NEVER LET THE RESERVOIR RUN DRY. ALWAYS KEEP IT AT LEAST 1/3 FULL.**

- 3) After bleeding both wheels and topping of the master cylinder make 20-30 applications of the brake pedal. If a hard pedal is experienced, no further bleeding is required. If pedal is spongy, repeat bleeding process until a hard pedal is achieved.

### **FINAL INSPECTION**

- 11) Once a hard pedal is achieved, all fittings and connections must be inspected to make sure there are no leaks. Also check the level in both reservoirs of the master cylinder and top off, if needed.
- 12) Put wheels back on the car and turn wheel by hand to insure that the wheel spins freely and does not interfere with any brake components. If any interferences are detected, DO NOT drive vehicle until problem can be identified and corrected.

**DO NOT DRIVE IN TRAFFIC UNTIL THE BRAKES SAFELY STOP THE CAR IN A SAFE DISTANCE WITHOUT A SPONGY PEDAL FEEL!**

**BRAKING TESTS SHOULD ALWAYS BE DONE IN A SAFE OPEN AREA!**

**NOTE: For frequently asked questions and technical reference information please visit the tech section of our website at [www.ssbrakes.com](http://www.ssbrakes.com).**

**TECH LINE --** If technical help is required, please call 716-759-8666.

**NOW ENJOY TRUE PERFORMANCE BRAKING!**

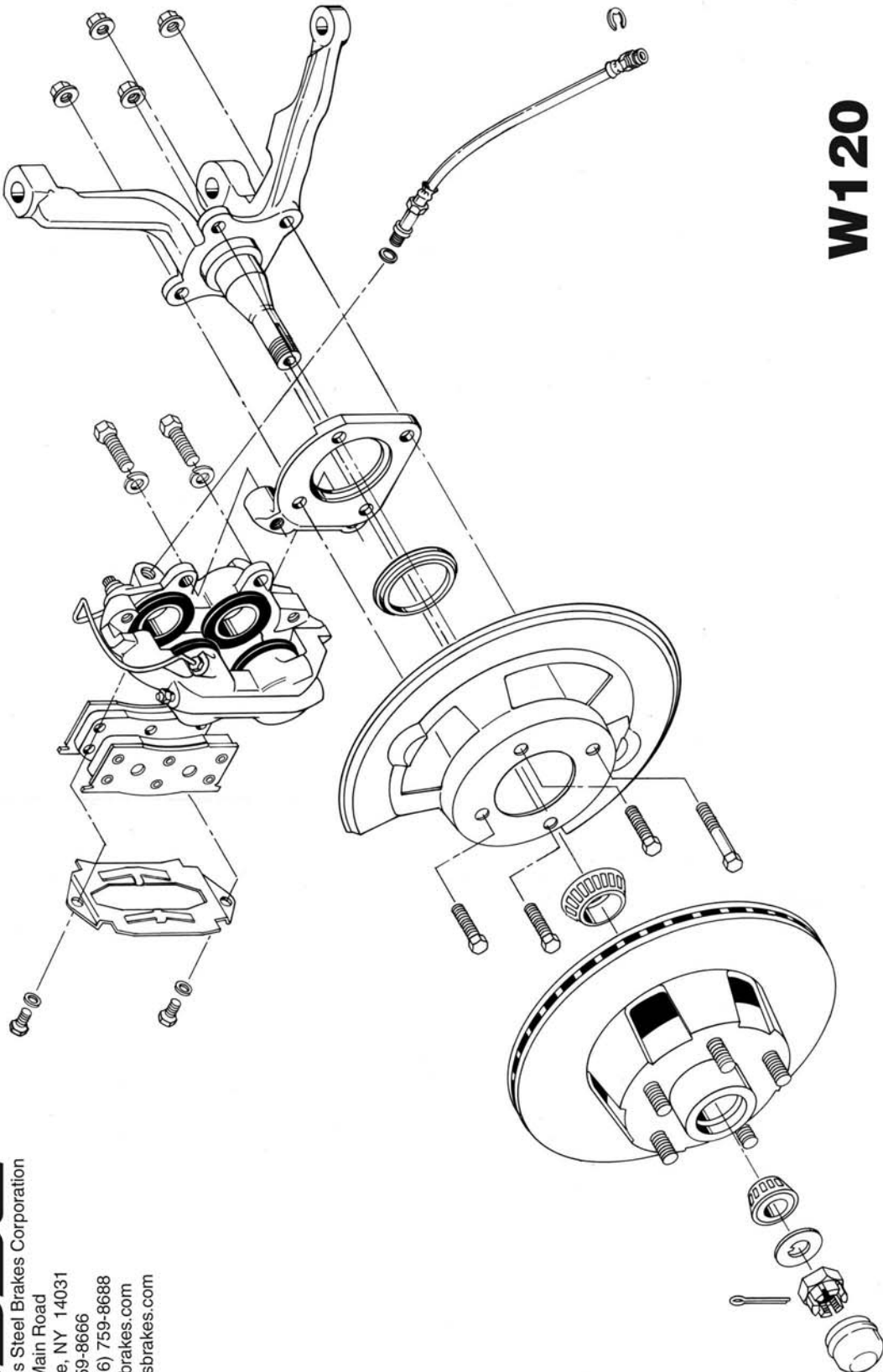

**W120**



Stainless Steel Brakes Corporation  
11470 Main Road  
Clarence, NY 14031  
(716) 759-8666  
Fax: (716) 759-8688  
www.ssbrakes.com  
tech@ssbrakes.com

## POSSIBLE INTERFERENCE BETWEEN SPLASH SHIELD AND CALIPER.

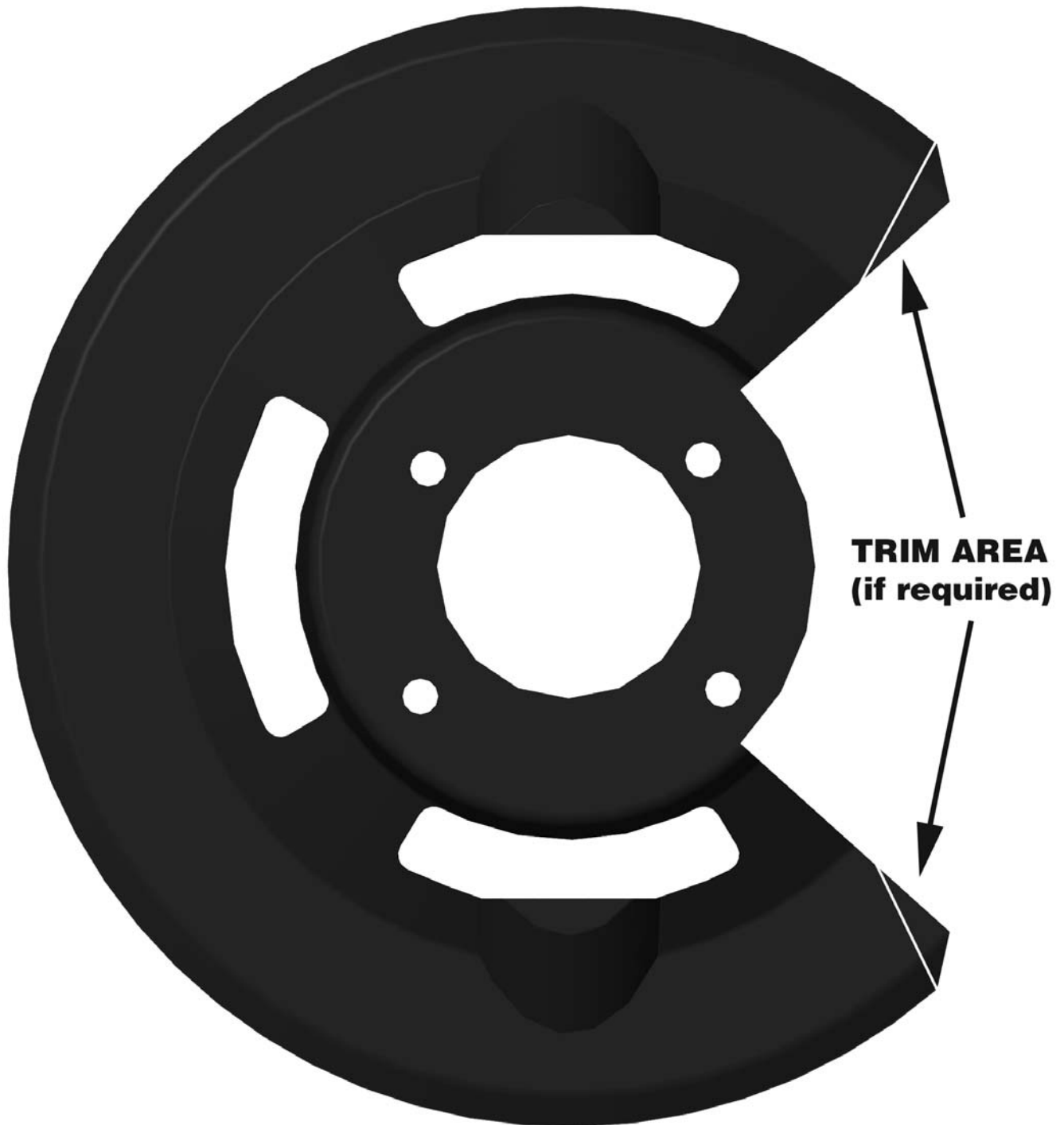

Since this part is made by a vendor beyond our control, we occasionally encounter parts that fall outside ideal tolerance, which will cause interference between the shield and the caliper housing. If you experience this interference, slight trimming of the shields in the marked areas will correct the problem.

We have been told that this situation also occurred during the original production of 1964.5-67 models.

# How and why do I bench bleed a master cylinder?

When installing or replacing a master cylinder, it is critical that all air is removed from the master cylinder. This can easily be done by bench bleeding the master cylinder prior to installation. Using the SSBC master cylinder bleeder kit (#0460):

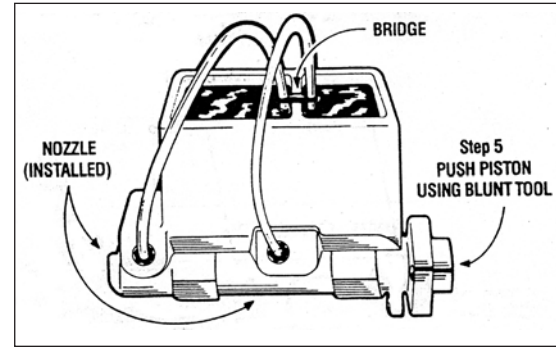

- 1) Place your master cylinder in a vise by the ears (not body). Make sure it is level.
- 2) Attach a piece of clear plastic hose to the short end of one of the plastic nozzles. Do the same to the other hose and nozzle.
- 3) Clip the plastic bridge to the wall and push the ends of the hose through the holes so they are SUBMERGED in the reservoir on either side of the wall.
- 4) Press the tapered end of the nozzle FIRMLY into the cylinder port hole with a twisting motion. Repeat this procedure on the other port hole.
- 5) Fill the reservoir with CLEAN brake fluid recommended by the manufacturer.
- 6) Using full strokes, push the piston in, then release. Do this until ALL the air bubbles have disappeared from the clear plastic hose. **(CAUTION-MASTER CYLINDER WILL NOT BLEED PROPERLY UNLESS HOSES ARE SUBMERGED IN BRAKE FLUID UNTIL THE BLEEDING PROCESS IS COMPLETED.)**

Now mount master cylinder and avoid brake fluid leaking out of front and rear ports during installation.

## Bleeding steps for Dual Port Master Cylinder

If you have a master cylinder with dual port holes (4 port holes - 2 on each side), it is necessary to bleed both port sides of the master cylinder. If both sides of the master cylinder are not bled, there will be air trapped in the master cylinder and your brakes will not function properly.

To bleed dual port master cylinders:

- 1) Follow steps 1 - 6 above on the side you will be hooking the brake lines to. Plug the other side.
- 2) Once the air bubbles are no longer visible in the plastic hose, open the bleeder screws in the supplied plugs and allow the mater cylinder to gravity bleed. **DO NOT** push the master cylinder piston in while the plugs are gravity bleeding.
- 3) When clear, steady streams of fluid are coming out of both bleeders, close and tighten the bleeders. Give the master cylinder piston several strokes, making sure there are still no bubbles present in the clear plastic tubes.
- 4) Remove the tubes and plastic fittings and mount the master cylinder on the vehicle being careful not to spill brake fluid on any painted surfaces.

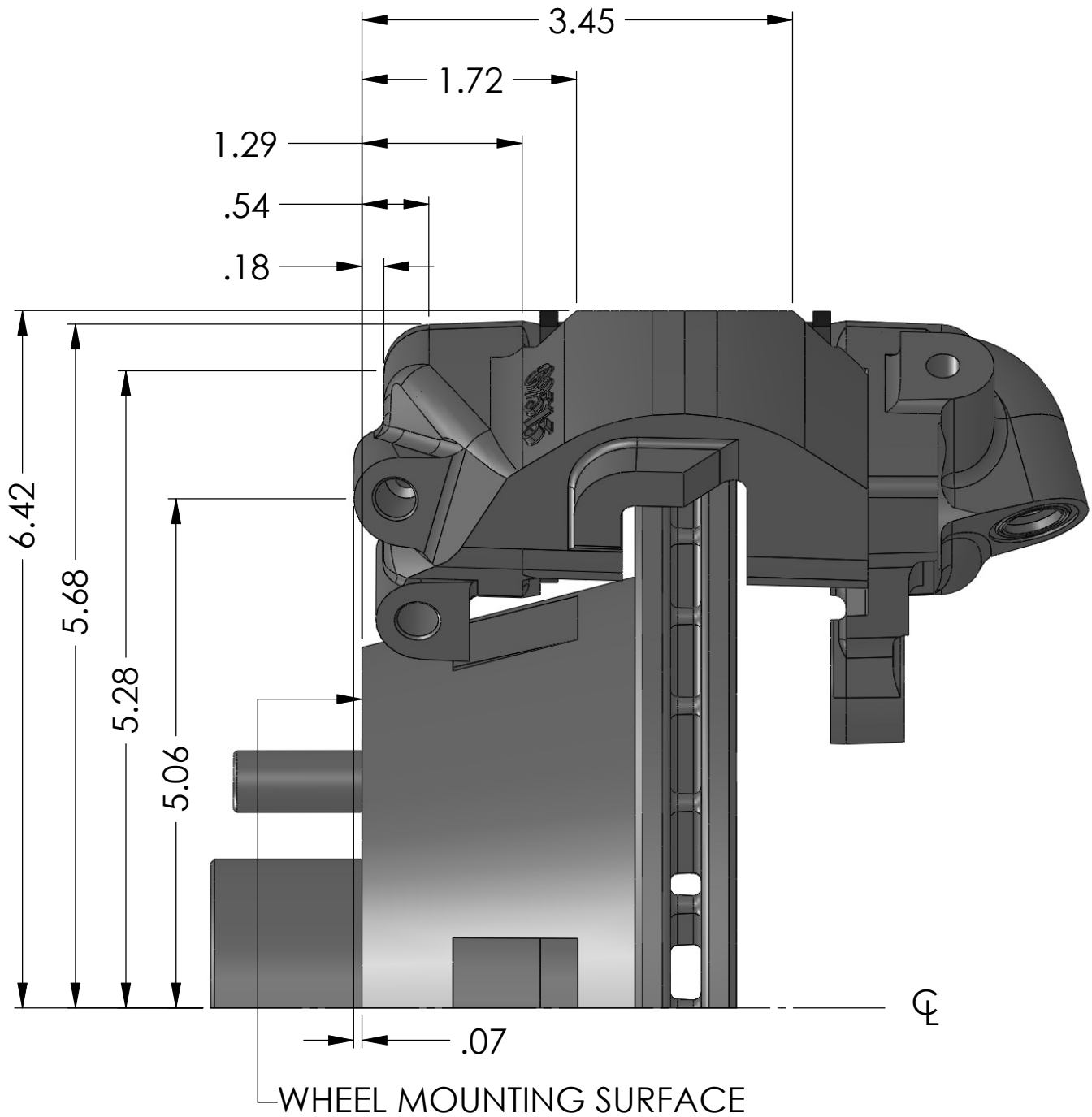

DIMENSIONS ARE IN INCHES

TEMPLATE NO.  
T-036

DO NOT SCALE  
DRAWING

REV  
-

**SSBC**

STAINLESS STEEL BRAKE CORP.

CLARENCE, NEW YORK 14031-1720  
Ph: 716-759-8666 / 800-448-7722 ~ Fx: 716-759-8688  
WWW.SSBRAKES.COM