

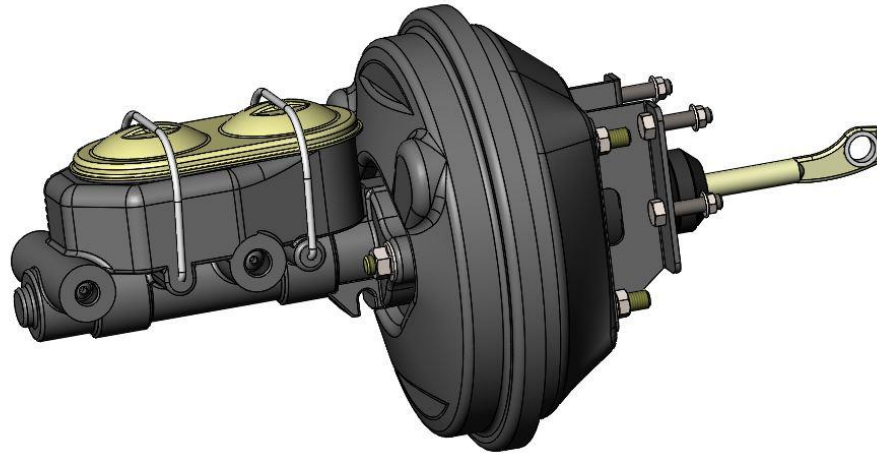

**Master Power Brakes**  
**Power Booster Conversion Kit**  
**64-66 Ford Mustang**  
**P/N: BM15204-1 or -2**



Thanks for your purchase of our Power Brake Conversion Kit for the 64-66 Ford Mustang applications. This is a simple installation requiring very minimal vehicle modification. Once installed, you will experience that nice easy to operate power pedal that you are looking for. The system does require an engine making 18" of vacuum and is designed to work with either disc/drum or disc/disc. If using 4-wheel drums, give us a call to make sure this system will still work for your vehicle.

**Installation Notes:**

- Please read all instructions before attempting the installation.
- Proper operation of your brakes is essential for your safety and the safety of others. Any brake service should be performed by a professional technician experienced in the installation of brake systems.
- Any installation requiring you to remove a wheel or gain access under the vehicle requires use of jack stands or a lift appropriate to the weight of the vehicle. In all cases, recommended ratings for jack stands should be at least 2-tons. If using a floor jack, be sure to use the appropriate wheel chocks.
- All installations require proper safety procedures and protective eyewear.
- A selection of hand tools sufficient to engage in the installation of these products is assumed and is the responsibility of the installer to have in his/her possession prior to beginning this installation. All installations, which require removal of hydraulic hoses and/or bleeding of the brakes, require appropriate fitting/line wrenches, as well as a safety catch can and protective eyewear. Other than these items, if unique or special tools are required they are listed in the section for that step.
- **ALWAYS CONFIRM WHEEL FITMENT PRIOR TO BEGINNING THE INSTALLATION OF ANY BRAKE SYSTEM!!** Returns will not be accepted for ANY installed part or assembly. Use great care to prevent cosmetic damage when performing wheel fit check!
- Before starting the installation, verify that all parts are included with the brake kit. If items are missing, notify Master Power Brakes immediately.
- Master Power Brakes requires the use of a high quality DOT 3 or DOT 4 brake fluid. Synthetic DOT 4 fluids are acceptable. **ALL WARRANTY IS VOID IF SILICONE DOT 5 FLUID IS USED.**

If you have any questions regarding installation, feel free to contact Master Power Brakes at (888) 351-8781 or through our website at [www.mpbrakes.com](http://www.mpbrakes.com).

Parts List	
Quantity	Description
1	9" Single Diaphragm Booster
1	1" or 1-1/8" Bore Master Cylinder
4	5/16"-18 Hex Flange Nuts
1	Vacuum Hose Kit (Includes: 2' Vacuum Hose, 1/2" x 3/8" NPT Bushing, 3/8" NPT 90° Fitting, Syringe Bleeder, 1/2"-20 Plug, & 9/16"-18 Plug)

## Installation:

1. Remove the existing brake supply system from the vehicle.
  - a. Disconnect the push rod under the dash from the brake pedal and remove from the pedal along with the brake lamp switch.
  - b. Remove the brake lines from the master cylinder.
  - c. Unbolt the stock master cylinder from the firewall and remove it as well as the pushrod from the vehicle.
  - d. Clean the mounting area in preparation of the new brake booster assembly.
  
2. With everything removed, the factory threaded nuts in the pedal support must be drilled out to accept the bracket mounting bolts. To begin, with the upper bolts still in place, use a 3/8" drill bit and drill each of the factory nuts at the master cylinder location. Once those have been drilled, remove the upper bolts and repeat the same for each of those bolts. The firewall showing the location of each nut can be seen below in Figure 1.

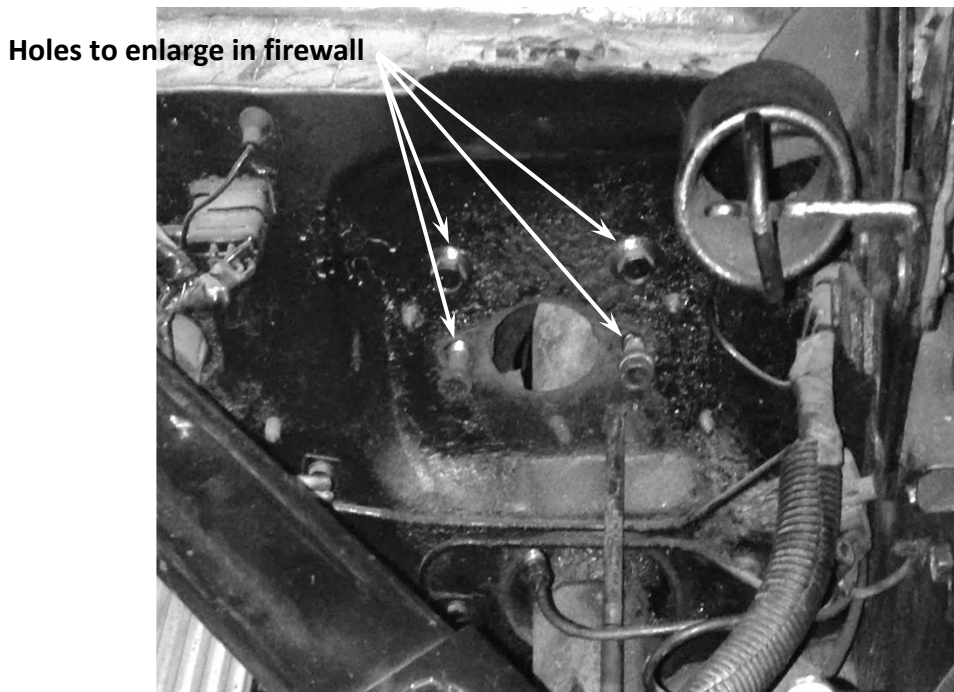

Figure 1 – Location of the Factory Nuts to be Enlarged

3. **THE SHOCK TOWER BRACE MAY REQUIRE A SIMPLE MODIFICATION.** The early Mustangs have one of a couple of different types of shock tower braces. Pictured below are the possible options and shown as Figure 2 and 3. Figure 2 on the left will require modification while Figure 3 should not. If you have the type shown in Figure 2, please read below for fitment notes.

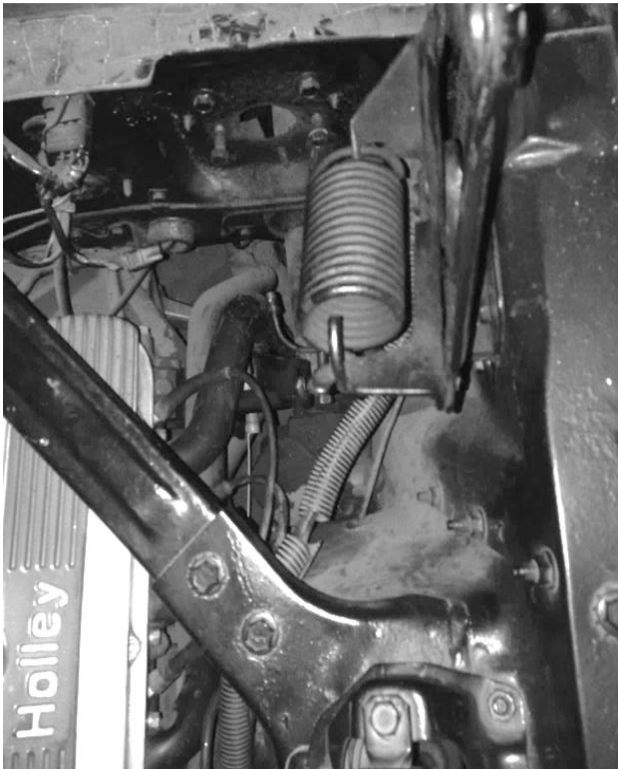

Figure 2 – Shock Tower Brace Possibly Needing Modification



Figure 3 – Shock Tower Requiring no Modification

- a. Figure 4 below shows the area on the shock tower brace that will possibly require modification. **NOTE:** If modification is necessary, remove only the material necessary to allow for clearance of the master cylinder along with the removal of the cap. **It is strongly recommended to pre-fit the booster/master assembly before cutting anything.**

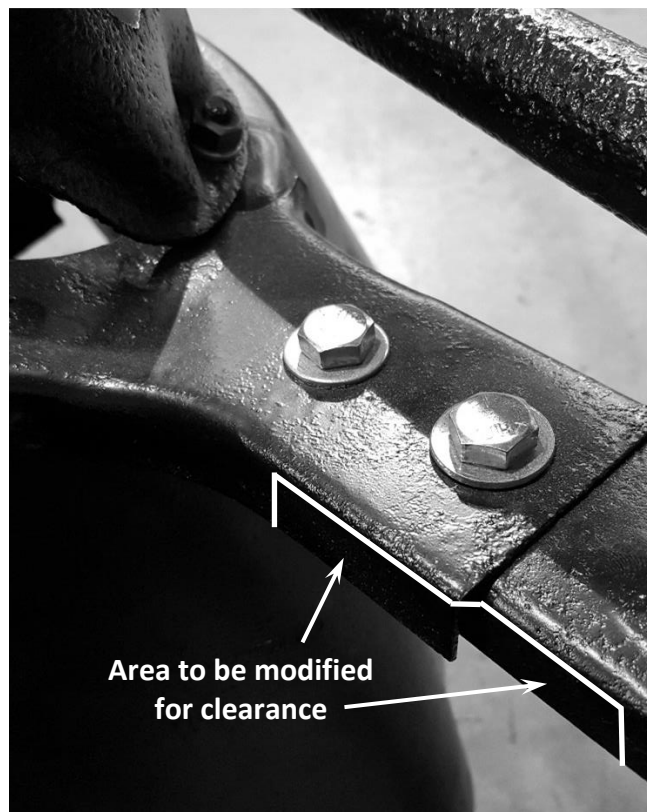

Figure 4 – Shock Tower Brace Modification

4. Test fit the booster assembly to the firewall to verify proper clearance between the engine along with any support braces or other accessories within the engine compartment. **NOTE:** Due to manufacturing inconsistencies along with various options for product placement, minor modifications or relocating of components may be necessary.
5. The booster and master cylinder can now be removed from the vehicle and prepared for bench bleeding of the master cylinder. To bench bleed the master cylinder, you have two options listed below:

**Syringe Bleeding** (Tools provided in system)

1. Position the master cylinder in a vise clamped by a mounting ear.
2. Pour brake fluid into each chamber of the master cylinder to between  $\frac{1}{4}$  and  $\frac{1}{2}$  full.
3. Using the syringe with the rubber tip attached, fill the syringe using the fluid in the master cylinder chamber. Fill the syringe to about half full.
4. Press the rubber tip to the port on the master cylinder. Holding the syringe firm against the master cylinder, inject the fluid into the master cylinder. The fluid as it flows into the master cylinder will turn from bubbles in the chamber to a steady stream of fluid.
5. When pulling the syringe away from the master cylinder, fluid will drip from the port so have a damp towel handy to wipe off the master cylinder especially if you have painted it.
6. Plug the port with the provided plastic plugs from the Vacuum Hose Kit included with the system.
7. Once a steady stream has been detected, empty the syringe of fluid and then repeat steps 3 through 6 from above for the remaining port.

**Hose Bleeding** (Tools not provided in system)

1. Position the master cylinder in a vise clamped by a mounting ear.
  2. Pour brake fluid into each chamber of the master cylinder to between  $\frac{1}{4}$  and  $\frac{1}{2}$  full.
  3. Thread the plastic fittings into each port on the master cylinder and attach the hoses to the fittings. Route the hoses into the chambers on the master cylinder and secure. Make sure the hoses are submerged into the fluid.
  4. Using a large Phillips screwdriver inserted into the end of the master cylinder piston, press the piston slowly into the master cylinder and release. Repeat until there is no air coming from the hoses.
  5. Remove the hoses and fittings from the master cylinder. When removing the fittings from the master cylinder, fluid will drip from the port so have a damp towel handy to wipe off the master cylinder especially if you have painted it.
  6. Plug each port with the provided plugs from the Vacuum Hose Kit included with the system.
6. Install the booster/master combo on the firewall. Place the 5/16"-18 Flanged Hex Nuts on each stud under the dash and tighten.
  7. Position the booster pushrod onto the brake pedal using the provided bushing. When installing the pushrod and using the factory brake lamp switch, install everything as an assembly onto the pedal. **IMPORTANT:** Due to manufacturing variations, it may be necessary to grind a small amount of material from the back side of the pushrod if the operation of the system will not allow the brake lamps to turn off. See Figures 6, 7 and 8 on the next page for installation photos.



Figure 6



Figure 7

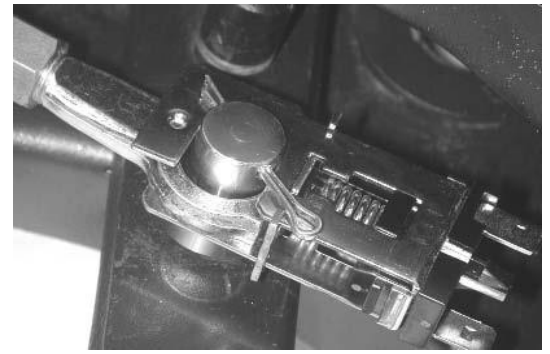

Figure 8

8. With the entire booster/master combo installed, the master cylinder can be plumbed into the vehicle. Figure 9 below shows proper front and rear hookups for the brake lines.

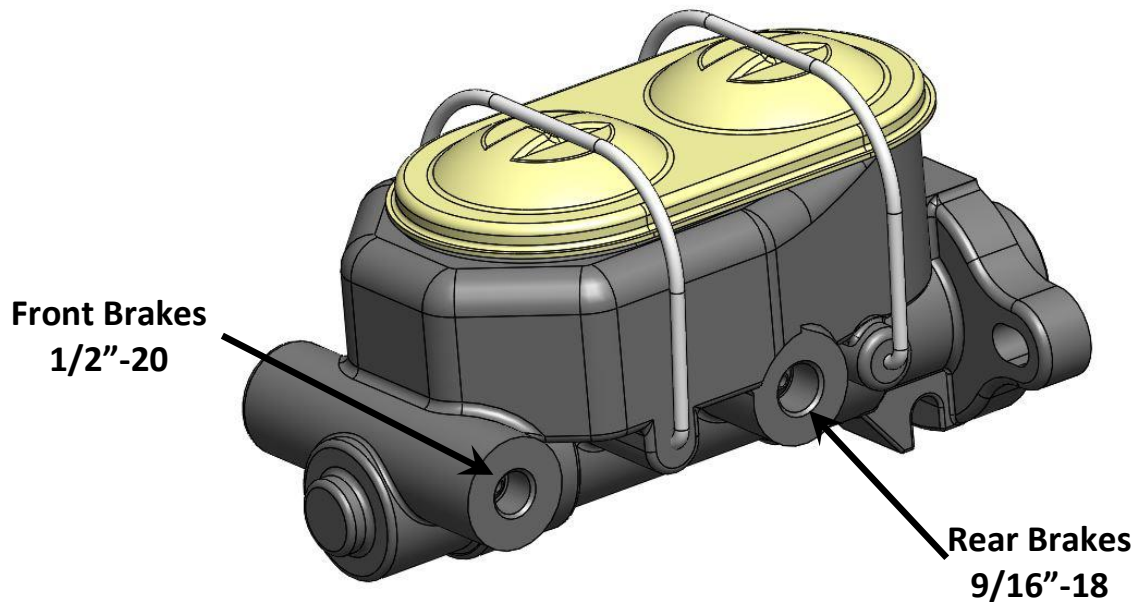

Figure 9 – Brake Line Routing

9. Using the provided fittings, install the vacuum tee in the engine. The best source for obtaining vacuum from the engine is to install the fitting in an intake runner in the intake manifold. **NOTE:** The provided fitting is a 3/8"-NPT fitting. For proper operation, find a location that does not require adapting to a smaller fitting and thread size if possible. Connect the provided hose from the fitting to the check valve on the booster.

***IMPORTANT: For proper operation of the brake booster, the engine must produce 18" of vacuum. Anything under 18" vacuum will produce a firm pedal.***

10. Bleed the brake system and the installation is now complete.

If you have any questions or comments, please call Master Power Brakes at (888) 351-8781.