

# Brake Caliper, Disc and Pads **Installation Instructions**

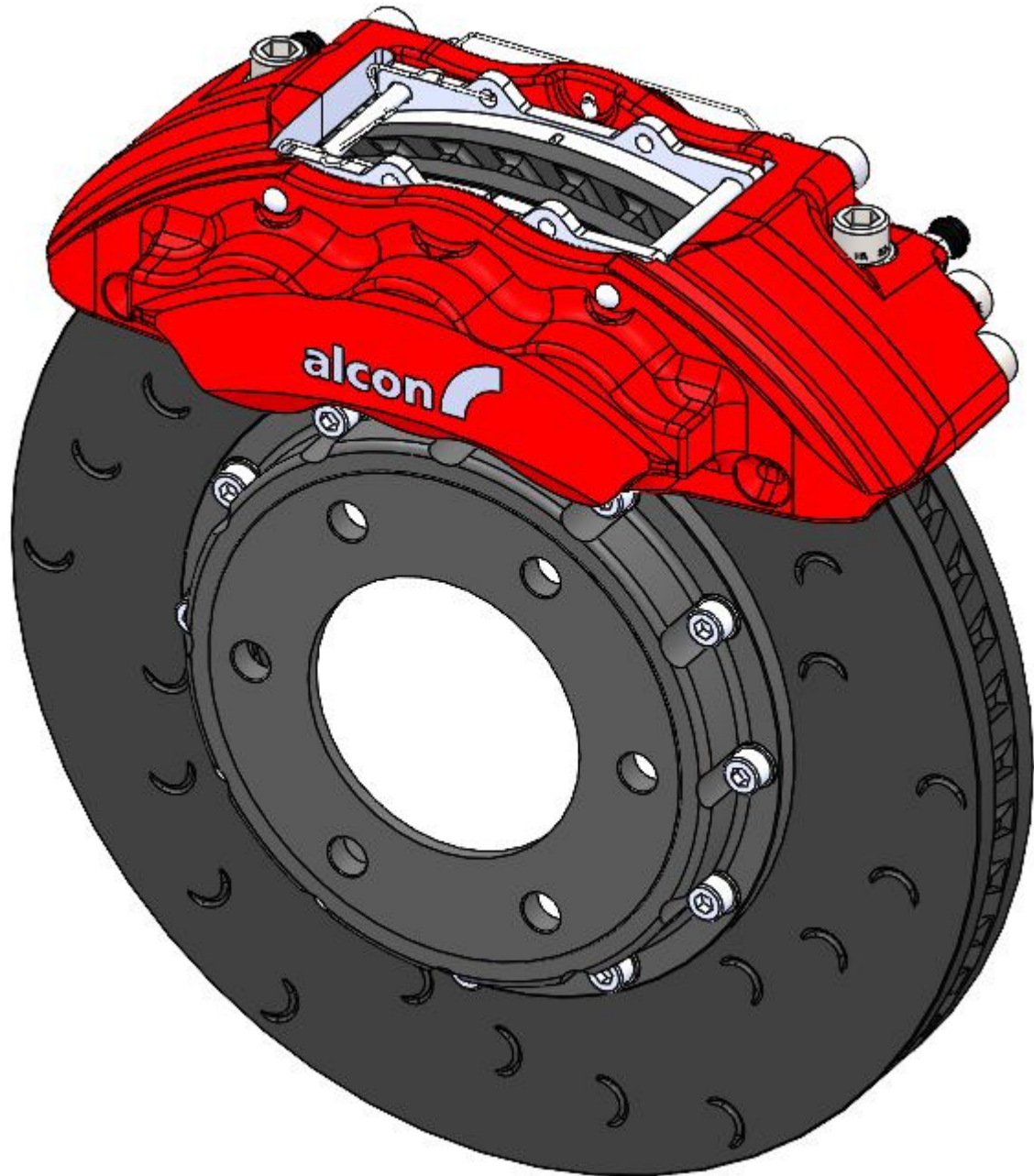

CIR15 Front Brake Kit  
Ford Ranger / Bronco - 2019  
BKF1551K61



## **BRAKE PRODUCTS LIMITED WARRANTY**

### **Limited 12 Month/12,000 Mile Warranty**

Alcon Components Ltd. ("Alcon") warrants that these brake products will be free from non-conformity in materials and workmanship for 12 months or 12,000 miles after installation, whichever comes first. In the event of a non-conformity, Alcon will repair or replace, at its sole discretion and option, the non-conforming product or part thereof free of charge. Simply contact Alcon using contact details to be found at [www.alconusa.com](http://www.alconusa.com) and [www.alcon.co.uk](http://www.alcon.co.uk) for instructions on obtaining repair or replacement. Any claims under this Limited Warranty must be made within 30 days of discovery of the non-conformity, or the claim will be null and void. Return of the non-conforming product or part thereof at the customer's expense, along with proof of purchase and/or mileage, may be required.

This Limited Warranty does not apply to brake products that have been damaged, misused, altered, or installed or used in a manner contrary to Alcon's instructions. Wear and tear on these brake products is normal, and is not an indication of a non-conformity. This Limited Warranty applies only to aftermarket brake products installed on passenger cars, vans and light trucks for on-road use. This Limited Warranty does not apply to any other use, including but not limited to racing, military (except for standard road vehicles armored for occupant protection), off-highway recreational, or off-highway competition.

**DISCLAIMER: THIS WARRANTY IS LIMITED TO REPAIR OR REPLACEMENT ONLY.** This Limited Warranty does not cover labor for removing or reinstalling the non-conforming brake product or part thereof, or for the labor or costs of other materials removed or reinstalled in order to repair or replace the Product or part thereof. TO THE EXTENT PERMITTED BY LAW, ALCON, AND ITS AFFILIATES, DISTRIBUTORS, RETAILERS OR AGENTS, DISCLAIMS ALL OTHER IMPLIED OR EXPRESS WARRANTIES INCLUDING ALL WARRANTIES OF MERCHANTABILITY AND/OR FITNESS FOR A PARTICULAR PURPOSE, AND WARRANTY AGAINST INFRINGEMENT. TO THE EXTENT THAT ANY IMPLIED WARRANTIES MAY NONETHELESS EXIST BY OPERATION OF LAW, SUCH WARRANTIES ARE LIMITED TO THE DURATION PROVIDED BY LAW.

**LIMITATION OF LIABILITY:** This Limited Warranty is your sole and exclusive remedy and ALCON, and its affiliates, distributors, retailers or agents, shall not be liable for any damages, whether direct, indirect, incidental, special, consequential, exemplary, or otherwise, including property damage, lost revenues and lost profits, arising out of any theory of recovery, including statutory, contract or tort. Notwithstanding the term of any limited or implied warranty, or in the event that this Limited Warranty fails of its essential purpose, in no event will ALCON's, or its affiliates', distributors', retailers' or agent's, entire liability exceed the purchase price of this product. Some states do not allow the exclusion or limitation of incidental or consequential damages so the above limitations or exclusions may not apply to you. Some states do not allow limitation on how long a limited warranty lasts, so the above limitation may not apply to you. This Limited Warranty gives you specific legal rights, and you may also have other rights which vary from state to state.

Alcon Components Ltd., Apollo, Tamworth, Staffordshire, B79 7TN, United Kingdom  
Revised – July, 2016

## **Notes and disclaimers concerning application**

### **Important: Read these instructions carefully before fitment.**

Alcon has engineered the brake kit to replace the original brake calipers and discs. Where there is doubt about the suitability of the product (on armoured applications for example), Alcon can run individual brake system calculations



**Caution:- This brake kit must be installed by a competent and suitably qualified person. It is the installer's responsibility to ensure that any brake products fitted to a vehicle are suitable for application.**

### **Installation and clearance**

These parts have been designed using information available at the time of design. There may be fitment issues on specific issues due to:-

- Model year change over.
- Regional vehicle specification variations.
- Non-standard wheel profiles.

Alcon brake kits have been test installed on vehicles with a variety of specific wheels fitted. Alcon is unable to test install with every available wheel. The customer is responsible for ensuring sufficient wheel clearance. 1:1 radial profile templates are available at the end of this document to assess if sufficient clearance to the wheel is available. Templates come with full instructions on how to use them. It is very important that templates are printed accurately to scale. Due to differences in profile, it cannot be assumed that a larger diameter wheel will fit where a smaller one may not. Vehicle production tolerances may exceed those that the kit will accommodate, and the points in this document must be carefully observed during installation to ensure that the correct clearances are maintained.

### **Wheel Spacers**

The use of wheel spacers will widen the track width of the vehicle. This should be kept to a minimum. It is the responsibility of the customer to ensure that this falls within the requirements for air transportation where applicable. Alcon accepts no liability whatsoever for any issues of any sort arising through the fitting of wheel spacers.

### **Pad and disc life**

Alcon brake kits are designed to give increased pad area and disc thermal capacity. This will give improved disc and pad life when compared to the original brake system if used at the armoured weight. Depending upon the environment and use, brake pad and disc wear can vary considerably from one vehicle to another. Potential reasons for accelerated wear are as follows:-

#### 1, Environment

Some driving environments generate an aggressive paste between disc and pad that continually grinds the pad and disc when the brakes are not being applied. Typical environments where this may occur include quarries and desert conditions.

#### 2, Driving style

Brake pad life is not directly related to distance travelled. The number of brake applications and their severity vary significantly. If a driver is continually making heavy braking events then they are not only wearing the pads by the number of applications but accelerating the wear by running the brakes at a higher temperature. Brake pads wear more quickly at higher temperatures.

#### 3, Brake drag

If, for any reason, the pad is continually in contact with the disc the pad and disc will wear more quickly due to friction and temperature. This could be from some sort of locked pressure, seized piston, seized pad, etc.

Alcon accepts no liability whatsoever for accelerated rate of pad or disc wear howsoever caused.

### **Brake noise**

Alcon have made every effort to ensure a quiet brake. Brake noise is generated by vibrations in the whole vehicle corner. A brake kit may be quiet on one vehicle make and have noise present on another.

To maintain good performance on higher performance vehicles, Alcon use higher than normal friction pad materials. These materials can be more prone to brake squeal.

Alcon accepts no liability whatsoever for any brake noise howsoever caused.

# **Notes and disclaimers concerning application (Cont'd)**

**Important: Read these instructions carefully before fitment.**

## **Vibration**

Alcon brake discs are manufactured by a methods that keep run-out and thickness variation to a minimum. They are also balanced to strict tolerances. Where a two-piece disc is supplied, the disc is finish-machined and balanced as a full assembly.

Vibration can become present should pads and discs:-  
Not be installed correctly  
Not be correctly bedded-in  
Be subject to extreme abuse

Alcon accepts no liability whatsoever for vibrations caused by incorrect installation, improper bedding –in or extreme use.

## **Paint damage**

Brake fluid will damage most painted surfaces. Always try to contain or catch brake fluid during removal or fitting of brake components.

Immediately clean any brake fluid spilled onto any painted surface with clean water.

Alcon accepts no liability whatsoever for any damage to paintwork resulting from spilled brake fluid.

## **Heat Soak**

After heavy use, do not rest your foot on the brake pedal while the vehicle is stationary. This practice will cause heat to 'soak' from the disc to the caliper and so to the brake fluid.

In extreme cases the fluid may boil, leading to very poor braking performance.

In addition, maintaining contact between pads and discs when stationary can cause pad material to adhere to the disc face and give rise to vibration.

It is good practice to always use the handbrake rather than the footbrake when the vehicle is stationary.

## **General modifications**

Do not make any modifications to the parts supplied in the brake kit.

Alcon accepts no liability whatsoever for the consequences of using brake products that have been modified without its express written approval.

*Keep this document with your Owners Handbook for reference.*

*Every effort has been made during the preparation of this literature to ensure that the information provided is correct. However, Alcon reserves the right to change information without notice.*

# CIR15 Caliper Assemblies

Kit K61 Painted Red, White logo

CIL1551K40HZLL-RT021A01  
CIL1551K40HZLT-RL021A01



**Important: The caliper housing must not be split by removing and refitting the bridge bolts. Doing so may effect the strength and safety of the caliper.**

**Alcon accepts no liability whatsoever for brake components that have been de-assembled.**

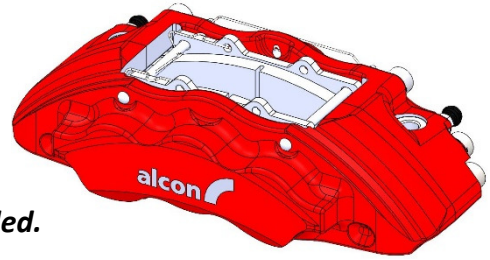

ITEM NO.	PART NUMBER	DESCRIPTION	QTY.
1	CIR1551K40	CALIPER BOLTED SUB-ASSEMBLY	1
2	PNS4415X511	MODIFIED BRAKE PAD	2
3	03.3590-0700.1	BLEED SCREW CAP	2
4	03.3518-0066.1	BLEED SCREW M10x1.0	2
5	MPD0080X186	DISPOSABLE DUST CAP	1
6	PSR4415X546	PAD RETAINING PIN	2
7	SSA4415X541	ANTI-RATTLE SPRING	1
8	SSR4415X542	PAD PIN RETAINING SPRING	1
9	PSS4133X504	Ø41.27X33 PISTON STEEL 04	6
10	SNW4100X605	Ø41.3 WIPER SEAL	6
11	SES4100X604	Ø41.3 SEAL EPDM	6
12	FPC3430X657	'A' FACE PROTECTIVE FILM	1

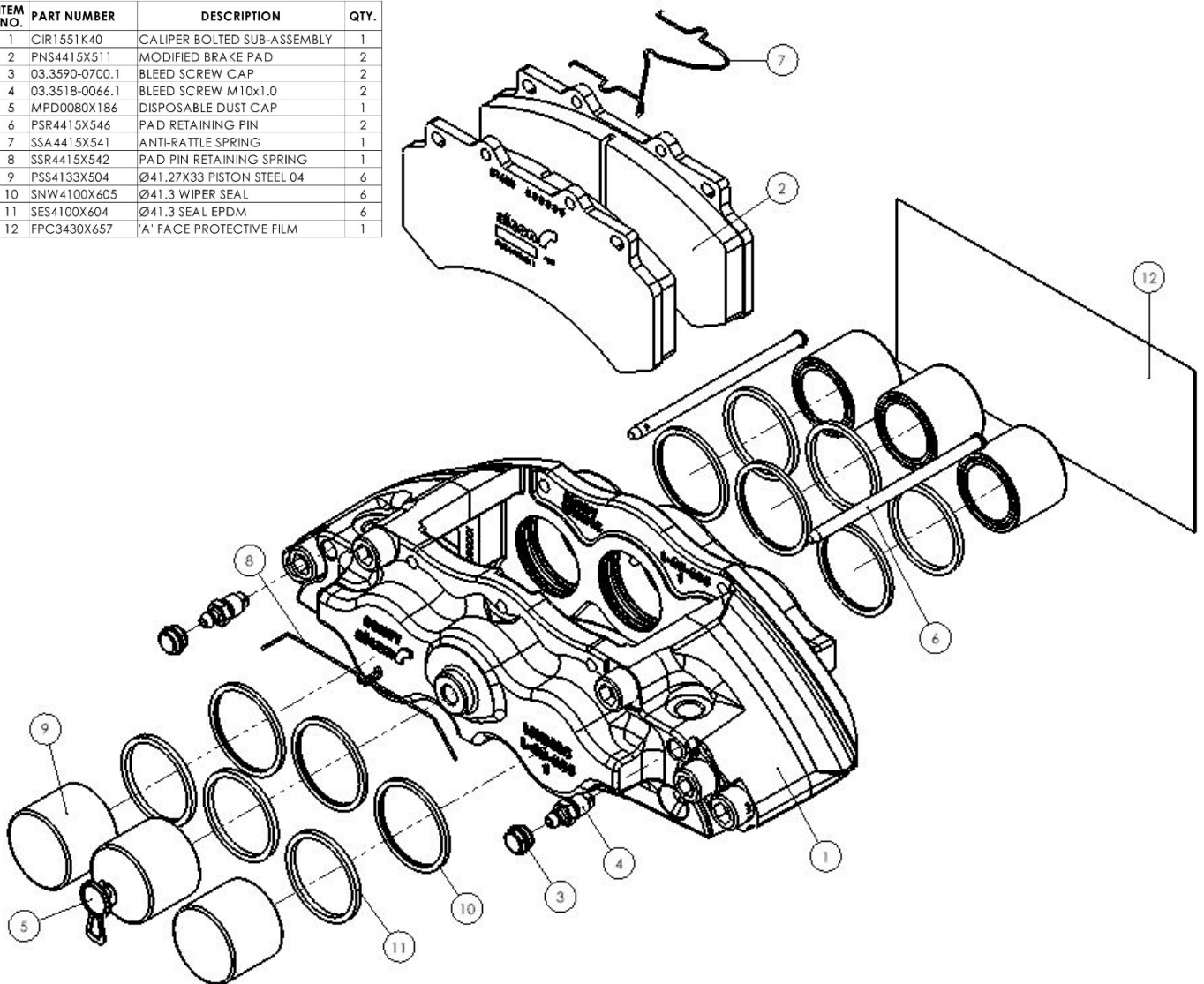

# **BSK4415X619** **Front Bracket Kit**

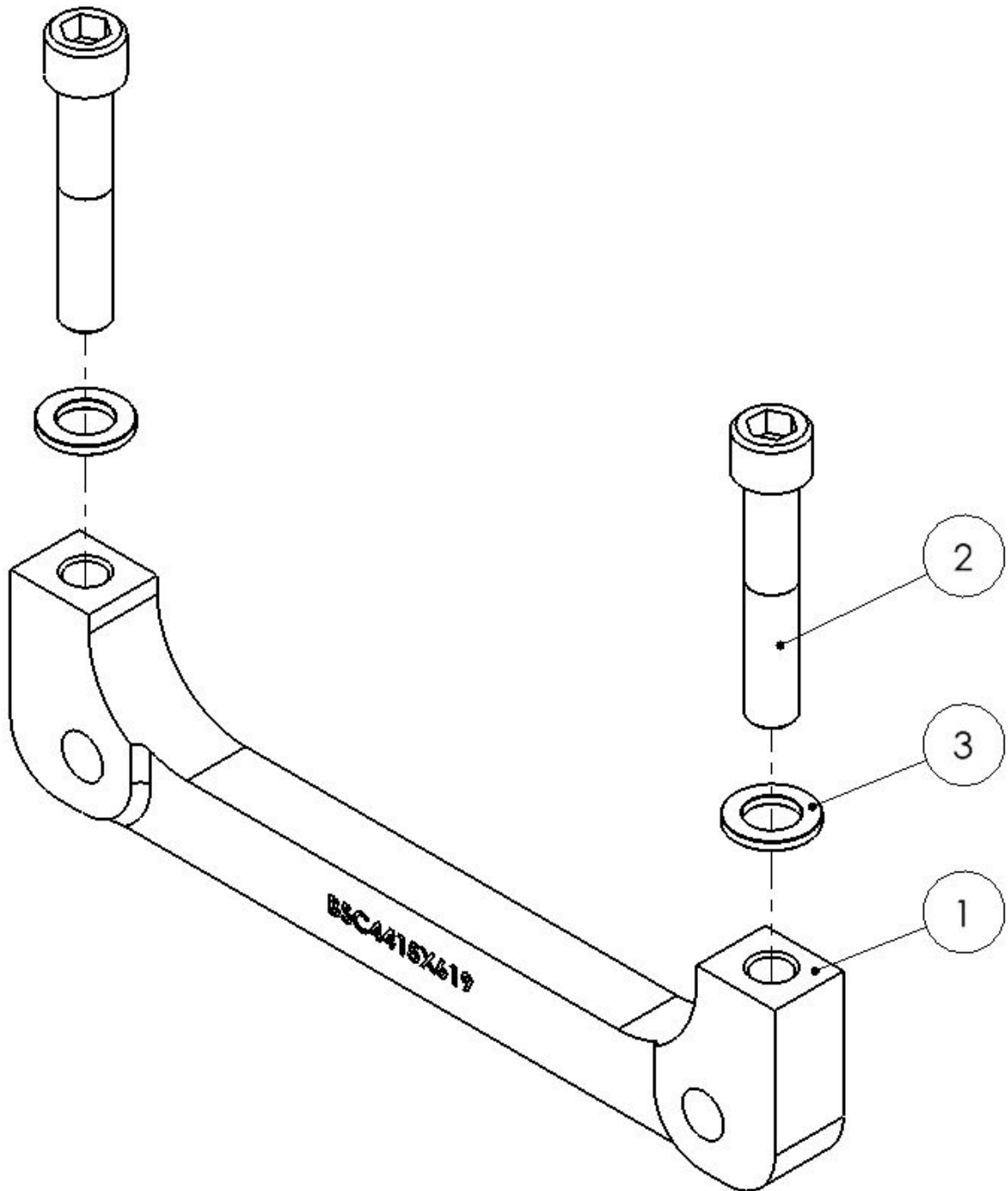

ITEM NO.	PART NUMBER	DESCRIPTION	QTY.
1	BSC4415X619	BRACKET	1
2	BSS0080X1054G	M12x1.75x65 BOLT	2
3	WSF0080X692	WASHER	2

# DIA2175X240C24L & C24R Front Brake discs

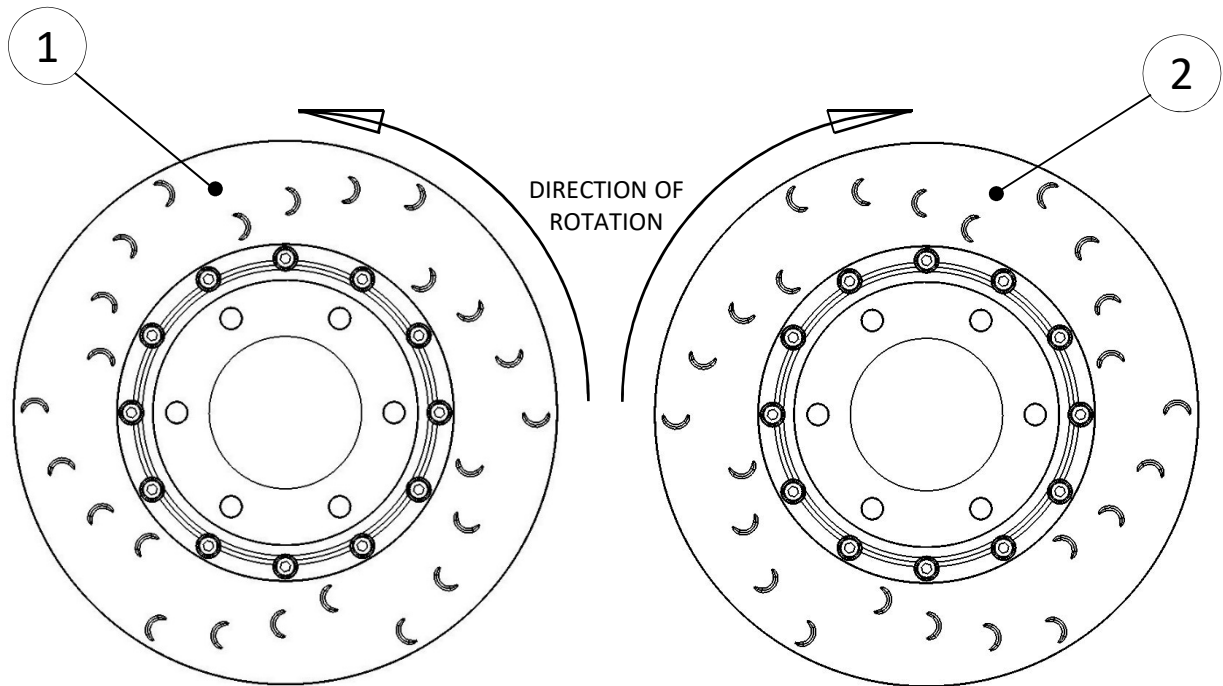

ITEM No.	PART NUMBER	DESCRIPTION	QTY
1	DIA2175X240C24L	DISC ASSEMBLY LH	1
2	DIA2175X240C24R	DISC ASSEMBLY RH	1

## **Installation instructions**

- If applicable, apply the parking brake.
- Raise the vehicle on suitable lift or axle stands.



**Caution:- If using a jack - ensure the vehicle is standing on a hard, level and clean surface. Do not leave the vehicle supported using only the jack. Always use axle stands.**

### **Fit the new front bracket kit**

- Position the bracket to the correct mounting face on the vehicle hub  
*Note- that the face of the bracket marked 'DISC' should be towards the disc.*
- Secure using the supplied bracket mounting bolts
- Torque these bolts to the manufacturer's recommended setting.

### **Fit the new front and rear discs**

- Ensure that the hub flange is completely flat and clean.
- Note that any 'bruising' or out of flatness will cause brake vibration.
- If necessary, prepare the hub face to remove any high spots prior to fitting the brake disc. The brake discs are handed by the direction of the grooves cut into the disc friction surfaces. They must be fitted to the correct side of the vehicle. Direction of rotation is marked on the outside diameter of the disc. This is also shown in the image (right).
- Fit the disc to the hub.
- With the disc assembled to the hub, check that there is a minimum of 5mm clearance between the disc inner face and the lower suspension/steering joint.
- Discs should always be changed in axle sets.

### **Fit the new front caliper**

Ensure that the brake pads, pad retaining pins and anti-rattle spring are fitted to the caliper.

- Position the caliper over the disc and secure to the bracket using the supplied caliper to bracket mounting bolts x2 (BSS0080X1054G M12x1.75x65 head Cap heads).  
Ensure washers are fitted and do not fully torque the bolts at this stage.

The caliper has been designed specifically for the application and clearances have been checked so the caliper should fit without clearance issues. In case there are any variations in vehicle specification – please check the following:

- To prevent overheating, radial clearance between the disc and caliper will not be less than 2mm in all directions.
- When the pads are fitted, the top edge of the pads will be around 0.8mm below the disc outside diameter.
- The disc must be central in the caliper within +/- 0.5mm.
- Check that the clearance between the outer diameter of the bell and the inner radius of the pad back-plate is at least 1.5mm. Use the 0.5mm shims provided to lift the caliper on the bracket or to adjust the bracket position until the caliper is correctly positioned. Fit an equal quantity of shims to each end of the bracket as required.
- Fit the road wheel to check there is a minimum of 2.5mm clearance between the wheel and caliper in all directions.
- Remove the road wheel.
- Torque the caliper to mounting bracket bolts (x2) to 108 Nm.
- Check that new pads move freely in the caliper.

## **Installation instructions (Cont'd)**

### **Re-fit the brake hoses**

- Connect the hose to the caliper. Ensure copper gaskets are fitted either side of the banjo (between banjo and caliper housing; between banjo bolt head and banjo).
- Torque the banjo bolt to the manufacturer's recommended setting.
- Ensuring hose is not twisted, re-connect it to the vehicle, including the original fastenings to the original manufacturer's recommended torque settings.
- Check that the brake hose length allows for all combinations of steering lock and suspension movement and that the hose does not come into contact with any suspension component, the wheel or the tyre in any position.
- Do not apply any twist into the brake hose.

### **Fit new rear pads**

- Pads are designed to be a direct replacement.
- Fit pads in accordance with the vehicle manufacturer's instruction.
- Pads should always be changed in axle sets.

### **Bleed the brakes**

- Bleed the brakes in accordance with the vehicle manufacturer's instructions.
- Only use DOT 4 brake fluid.
- The caliper bleed screws must be tightened to 18Nm (cold).
- To prevent damage to any painted surface, remove any spilled brake fluid immediately with clean cold water.
- Remove any fluid in the area around the bleed screw thread and in the end of each bleed screw.
- Check the complete hydraulic system for leaks before driving the vehicle.

### **Re-fit the road wheels**

- When the brake system has been sufficiently bled and a firm brake pedal has been achieved, replace the road wheels.
- Torque the wheel nuts to the original manufacturer's specification.
- The brakes should now be checked for correct operation by driving the vehicle, making a few light brake applications from low speed in a safe location. Stopping performance of a newly fitted brake kit will be low initially, as all friction materials require a period of bedding in before optimum performance is achieved.

### **Bedding new pads and discs**

Purpose: The two main reasons for bedding discs and pads in Alcon high performance brake kits are:-

- To thermally condition the discs by raising the temperature gradually, thus reducing thermal shock and preventing pad material from depositing unevenly on the disc surface.
- To wear material from the pad surfaces until there is full-face contact with the disc. This may take longer to achieve than the duration of the bedding procedure but pad area contact will increase during normal driving.

Procedure:

- Drive the vehicle to a road that allows the following procedure to be carried out safely and within the law.
- From any speed between 60 and 100 km/h, apply light to moderate pedal effort to reduce speed by about 50km/h. Avoid coming to a complete stop if possible and accelerate back to speed. After approximately ten applications, allow the brakes to cool by driving without further brake applications. It will take approximately 200 km of urban driving to complete bed-in of the pads.



**Caution:- This kit must be serviced by a competent and suitably qualified person. It is the installer's responsibility to ensure that any brake products fitted to a vehicle are suitable for the application.**

## **Servicing and maintenance instructions**

- Pads should be examined regularly for wear and condition.
- Replace pads when less than 2mm of friction material remains anywhere over the surface.
- When fitting new pads, thoroughly clean the pad location faces in the caliper, removing any debris and brake dust with brake cleaner and a stiff brush.
- The protruding pistons must be wiped clean before they are pushed back into the bores.
  
- Discs must be replaced when the total thickness has worn below the minimum indicated on the disc or when any of the face grooves across either inner or outer face have worn away.
- If a disc shows any sign of cracking, which may occur after heavy usage, it must be replaced.
  
- Remember to bed-in new pads and discs as described on the previous page.

### Seal replacement

*As brake calipers are a safety critical part of the braking system, Alcon recommends that they are inspected and serviced regularly to ensure consistent performance. The main service item within the caliper assembly is the caliper pressure seal, although the pistons and their coating should also be inspected during a service.*

#### **Stage 1 – Soak Seals**

Soak new caliper pressure seals in the mineral oil hydraulic fluid for a minimum of 60 minutes prior to build.

#### **Stage 2 – Exterior Clean**

The exterior of the brake caliper should be clean before attempting the removal of the caliper pistons. The exterior can be cleaned using warm soapy water, and the caliper should be dried off prior to disassembly. Performing an exterior clean will reduce the risk of dirt and other contaminants entering the hydraulic system. It is acceptable to omit this process if a post strip down wash of all components is going to be performed prior to rebuild.

#### **Stage 3 – Piston Removal**

To ease removal of the caliper pistons, a self-centring block can be used. Alcon recommend using a suitably sized block, 34mm thick, between the pistons which centres itself within the caliper using the disc pathway (see image below).

With the block inserted, the caliper pistons can be moved forward under pressure (hydraulic or air). **Hands and other body parts must be kept well clear of the caliper pistons to avoid injury. In the case of using air pressure to drive the pistons forward, hands and other body parts should be kept away from escaping air.**

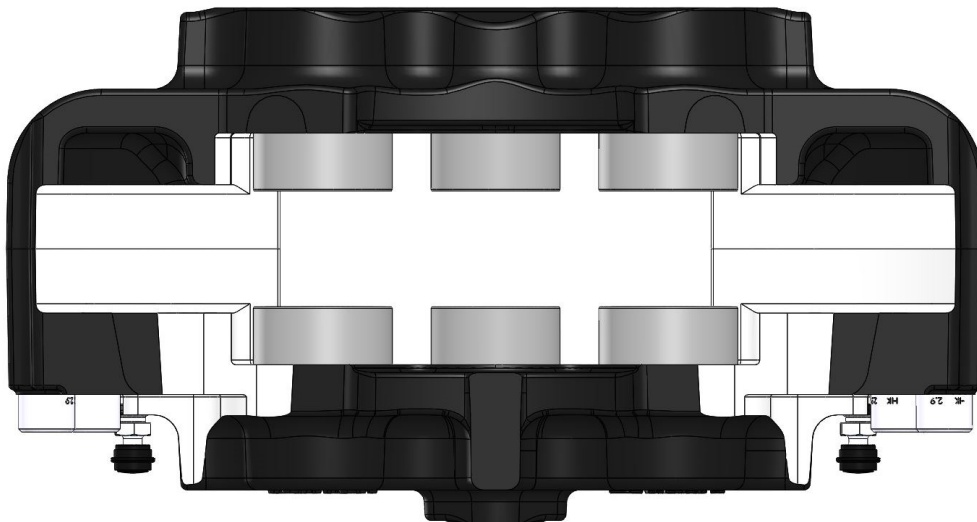
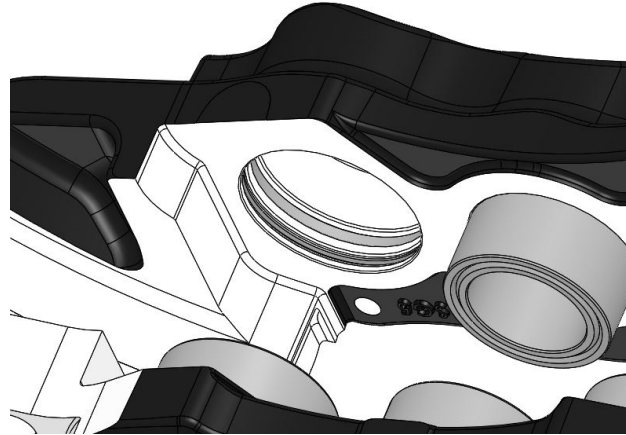

*Fig 1 – Caliper pistons moved forward to facilitate removal*

## **Servicing and maintenance instructions (Cont'd)**

### Seal replacement

Once pistons are protruding from the caliper bores, remove the pistons from the caliper (see image below).



### **Stage 4 - Seal removal**

Carefully remove old pressure seals and wiper seals from their grooves using a thin, blunt edged tool to prise the seal from the groove.

### **Stage 5 – Internal Clean**

The caliper bores, seal grooves and pistons should all be cleaned prior to re-assembly. Alcohol based cleaning agents may be used.

Ensure that bores, seal grooves and pistons are completely clean and free from contamination and moisture. Care should be taken when cleaning the caliper pistons so that no damage is caused to the piston coating. If the piston coating appears to be excessively worn, then the pistons should be replaced with new or reconditioned pistons.

### **Stage 6 – Rebuild**

Fit replacement caliper pressure seals and wiper seals into grooves ensuring that they are correctly seated. Seals should sit smoothly in the grooves and have no kinks or twists visible.

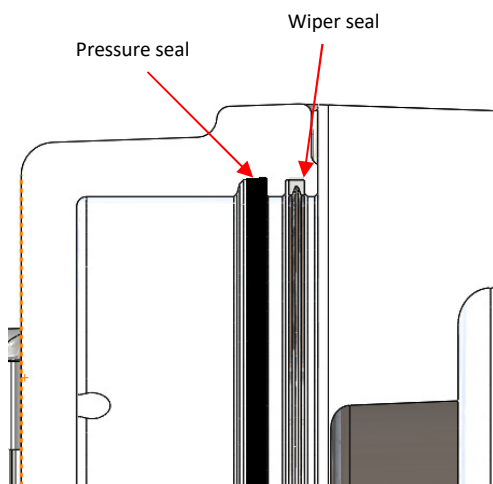

Note that the pressure seal is square in section and is fitted to the inner seal groove.

The wiper seal have a 'V' section and is fitted to the outer seal groove.

Apply a small amount of brake fluid to the corner radius of the piston at the base, as this will help with re-assembly.

Carefully engage the piston in its bore and apply even pressure to guide it through the pressure seal. Once fully engaged with the seal, the piston should be pushed to the bottom of its bore.

**DO NOT USE EXCESSIVE FORCE TO INSERT THE PISTON THROUGH THE PRESSURE SEAL.** If piston does not slide through the seal, remove the piston and check seal is correctly seated, re-apply lubrication (brake fluid) to both the seal and piston corner radius and re-insert.

Where possible, calipers should be pressure tested prior to use on the vehicle.

## **Servicing and maintenance instructions (Cont'd)**

### **Routine Servicing**

Vehicle braking system servicing must always be carried out strictly in accordance with the vehicle manufacturers instructions.

In order that vehicle braking systems remain in good working order and provide the essential safety and reliability, periodic checks and replacement of certain components is necessary.

### **Every month or 1500km**

1, Check fluid levels in reservoirs and top up if necessary with DOT5.1 brake fluid

### **Every 6 months or 10,000km**

1, Check the brake pads for wear. Replace pads when less than 2mm of friction material remains anywhere over the surface.

2, Check the brake discs for wear and damage. Discs must be replaced before the total thickness has worn below 32mm. This figure is marked on the outside rim of the disc.

If a disc shows any sign of cracking, which may occur after heavy usage, it must be replaced.

### **Every 18 months or 30,000km**

1, Completely drain the braking system and renew the hydraulic fluid (this period may be more frequent in high humidity territories).

2, Remove brake pads and check their condition particularly between the friction material and metal backing plate. If this is present, renew pads regardless of their state of wear.

3, Visually examine all hydraulic units for signs of fluid leakage. Replace or overhaul if necessary.

### **Every 3 years or 150,000km**

1, All hydraulic assemblies should be replaced or overhauled.



**Caution:- This kit must be serviced by a competent and suitably qualified person. It is the installer's responsibility to ensure that any brake products fitted to a vehicle are suitable for the application.**

## **Spare parts**

### **Front Kit (BKF155K61 – Painted Red Caliper, White Alcon Logo)**

Caliper assembly LT	CIL1551K40HZLL-RT021A01
Caliper assembly RT	CIL1551K40HZLT-RL021A01
Bracket kit	BSK4415X619
Brake disc LH	DIA2175X240C24L
Brake Disc RH	DIV2175X240C24R
Pads (Axle set)	PNS4415X511.4
Bleed screw	03.3518-0066.1
Pad retainer kit	PKR4415X546KS
Caliper seal kit	CSK414141EW604
Ø 41.3 Piston x1	PSS4133X504

## **Shelf life of spare parts**

All spare parts should be stored in cool, dry conditions in their original packaging. With the exception of those listed below, parts should not have a limit to their shelf life.

The condition of parts should be inspected should their packaging be damaged and before use.

### **Caliper assembly (no pads)**

Calipers have a very long shelf life due to the method in which they are built. The seals are assembled after being soaked in an assembly oil so it should be similar to it's as fitted condition.

It is recommended, that if calipers have been stored for over 10 years, then the condition of the pressure seals should be checked and replaced if necessary.

### **Caliper Seal kit**

Caliper seals have a 10 year shelf life. After this, parts should be disposed of and replaced.



**Phone :- +44 (0)1827 723700**  
**E-mail :- [info@alcon.co.uk](mailto:info@alcon.co.uk)**  
**[www.alcon.co.uk](http://www.alcon.co.uk)**

**Phone :- +1 (704) 799-2723**  
**E-mail :- [info@alconusa.com](mailto:info@alconusa.com)**  
**[www.alconusa.com](http://www.alconusa.com)**