



## GM LS/LT Engine Mount Components

### 71221016HKR, 71221017HKR, 71221018HKR, 71221019HKR, 71223015HKR, & 71223016HKR Installation Instructions



71221016HKR



71221019HKR



71223015HKR



71223016HKR

Thank you for choosing to use Hooker Blackheart LS/LT engine mount components as part of your performance vehicle project. These mounts may be used as direct replacement parts on any 1998-02 V8 equipped GM F-body vehicle (with 71221018HKR), or to perform an LT engine swap in a 1998-02 V8 equipped GM F-body vehicle (with 71221019HKR) using the factory frame stands. Additionally, they may be used to mount an LS or LT engine into a GM 1983-93 F-body or 1964-72 A-body vehicle using specific Hooker LS engine swap brackets developed for those applications. Please read these instructions thoroughly before attempting installation.

#### PRE-INSTALLATION CONSIDERATIONS:

These components were designed in conjunction with one another to eliminate the rivet-drilling operation typically required to install polyurethane inserts in 1998-2002 GM F-body vehicles.

Hooker Blackheart LS and LT clamshell housings are both stamped from thicker gauge steel than is typically used to manufacture clamshell housings of stock replacement LS engine mounts, which means they provide a stronger mounting foundation for high horsepower applications.

While easy to install, careful attention should be paid to the installation steps within this document to ensure the insert is not installed into the clamshell upside-down or backwards, which would cause in-car installation issues.

#### COMPATIBILITY INFORMATION:

Although Hooker Blackheart clamshell housings (LS and LT versions) were CAD designed specifically for use with Hooker Blackheart polyurethane inserts, they will physically accept GM 1998-02 F-body LS polyurethane inserts from Energy Suspension™ and Prothane™ also.

#### BEFORE BEGINNING...

Check that the hardware package includes the following:

**71221016HKR-** (1) **black** LS/LT polyurethane insert

**71221017HKR-** (1) **red** LS/LT polyurethane insert

**71221018HKR-** (1) **LS** engine mount clamshell (upper and lower halves), (4) 5/16 bolts, (4) 5/16 washers and (4) 5/16 lock nuts

**71221019HKR-** (1) **LT** engine mount clamshell (upper and lower halves), (4) 5/16 bolts, (4) 5/16 washers and (4) 5/16 lock nuts

**71223015HKR-** (2) M12 x 150mm flanged head, Grade 10.9, LS/LT engine mount/bracket couple-bolts, (2) M12 flanged nuts

**71223016HKR-** (4) 5/16 bolts, (4) 5/16 washers, and (4) 5/16 lock nuts (this is a replacement hardware kit for the fasteners included with the 71221018HKR and 71221019HKR engine mount clamshell kits).

#### INSTALLATION:

1. Install the insert between the upper and lower clamshell halves while ensuring that the following conditions of orientation are met:
  - A. The metal tangs protruding from the ends of the insert are offset towards the top of the clamshell halves (the side with a straight edge compared to the slight "V" shaped edge of the bottom side).
  - B. The longer end of the insert protrudes from the right side of the clamshell housing. This is the case with both mounts to be installed on an engine, which means when installed on the engine, the longer end of the inserts will point towards the front of the car on the passenger's side of the engine, and towards the rear of the car on the driver's side of the engine.
2. With the above conditions met, fasten the upper and lower clamshell halves together using the 5/16" hardware included with each clamshell housing. Install the fasteners in the orientation shown in **Figure 1** on the next page (LT clamshell shown, LS clamshell similar).

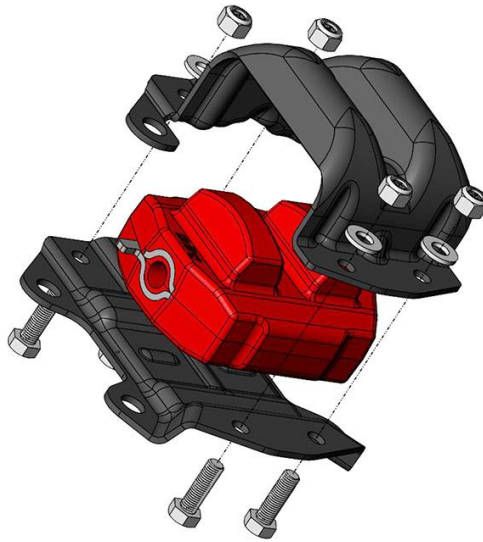

**Figure 1**

3. Ensure the two large holes in the bottom of the upper and lower halves are aligned to allow unobstructed insertion of M10 bolts through each of them and then torque the 5/16 bolt/washer/nut assemblies to approximately 29 ft./lbs.
4. Attach the clamshell/insert assemblies to the intended engine with user-supplied M10 fasteners with the straight edge of the clamshells facing up as depicted in **Figure 2**.

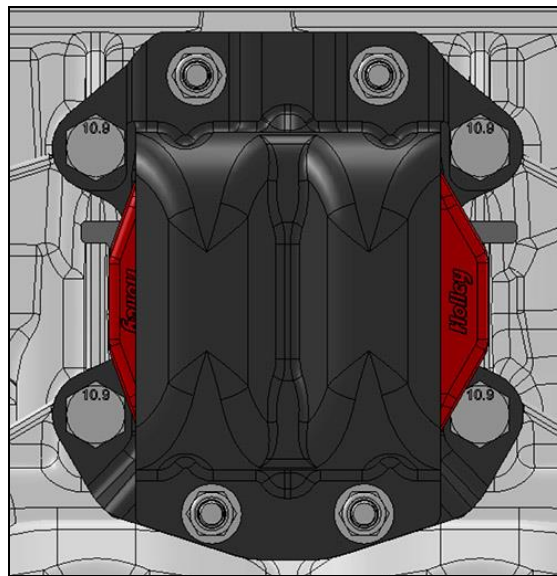

**Figure 2**

5. Lower the engine onto the vehicle engine mounting brackets and couple the engine mounts to the brackets using the M12 bolts and nuts included in the Hooker Blackheart 71223015HKR hardware kit, or with similar fasteners. Tighten bolt/nut assemblies

**LIMITATION OF LIABILITY – DISCLAIMER:**

HOLLEY/HOOKER™ makes no warranties of merchantability, of fitness for particular purpose, or that its products are approved for general use, or that its products comply with laws, regulations, or ordinances in the state where they may be sold to the ultimate purchaser, the consumer.

Unless expressly stated to the contrary in the catalog, instruction sheet; or price list, the entire risk as to the conformity of any company product in any such state and as to repair should the product prove to be defective or non-conforming, is on the retail purchaser, the buyer, the ultimate consumer, of such product and it is not upon the seller, distributor, or manufacturer.

In this connection, the retail purchaser, the buyer, the ultimate consumer assumes the burden of the entire cost of any and all necessary service, alterations, or repair.

© 2017 Hooker Headers, Inc. All rights reserved. Tous Droits Réservés.

**199R11359**

**Revision Date: 8-2-19**



## GM 1963-1972 C10 Crossmember Installation Instructions 71222024HKR



Thank you for choosing to use this Hooker™ transmission crossmember as part of your LS swap project. This crossmember is part of the most comprehensively engineered system of mounting components, headers, and exhaust systems available for this application. The entire Hooker™ swap system is designed to decrease your total swap installation effort and cost while increasing the engineered quality of your vehicle and compatibility of these components with other popular aftermarket components. Please read these instructions in their entirety before attempting installation.

### **COMPATIBILITY INFORMATION:**

This transmission crossmember was specifically designed for bolt-in compatibility with the HOOKER™ LS swap engine mounting bracket kit, cast iron LS exhaust manifolds, headers and exhaust systems also developed for this application. Various other Holley® components have been designed and/or validated for use with this system of components, as follows:

The engine/transmission positioning provided by this crossmember was designed for compatibility with the Holley® 302-2 and Holley 302-3 LS oil pans. Compatibility with other aftermarket/OE engine oil pans is unknown.

Hooker™ LS swap manifolds, LS Turbo manifolds, and long tube headers are compatible when installed using this Hooker LS engine swap transmission crossmember and the related Hooker BHS511 engine mounting bracket kit.

This crossmember was intentionally designed with high-tuck geometry to optimize the ground and dual exhaust routing clearances of this application.

More LS swap/engine performance components, such as EFI fuel control systems, fuel filters, fuel pumps, plumbing hose/fittings and valve covers can be found at [www.holley.com](http://www.holley.com).

Hooker recommends using a Prothane 7-1604 or Anchor 2268 transmission mount.

Designed for use with GM T56, 6L80, 4L80, 4L60, TH400, TH350, 700R4 transmissions

High hump floor pan will be needed when using 4L80, T56, 6L80 transmissions, and a bolt in tunnel is available from many C10 parts suppliers

It is recommended to install new body bushings before installing the new larger case transmissions

### **BEFORE STARTING:**

Your vehicle must be raised a minimum of 36 inches. A floor hoist is ideal. If no hoist is available, we strongly urge the use of axle stands as a safety measure. Please read these instructions in their entirety before attempting installation.

**CAUTION! WORK ONLY ON A LEVEL SURFACE. USE JACKS /JACK STANDS OF SUFFICIENT CAPACITY TO LIFT AND SUPPORT YOUR VEHICLE. NEVER WORK UNDER A VEHICLE SUPPORTED BY A FLOOR OR BUMPER JACK.**

**NOTE:** These instructions have been written with the assumption that you have already installed an LS engine into your vehicle using the Hooker BHS511 engine swap bracket kit. Satisfactory engine and transmission installation with any other type or brand of engine mounts is not intended with this crossmember.

## **INCLUDED HARDWARE:**

Qty.	Description
1	Center Crossmember
1	Left Side Mounting Bracket
1	Right Side Mounting Bracket

Qty.	Description
12	3/8" x 1" Bolts
12	3/8" Nuts

Depending on which crossmember you order, there will be a supplied spacer for your specific transmission. **Figure 1** shows the stack up of the spacer and transmission mount.

- T56 – no spacer
- 6L80 – 11/16"
- 4L80 – 1"
- 4L60 – 11/16"
- TH400 – 1"
- TH350 – 11/16"
- 700R4 – 11/16"

Check the hardware package. If anything is missing, please contact Technical Service at 1-866-464-6553 or 270-781-9741.

## **INSTALLATION:**

1. Raise the tail shaft of the transmission to its maximum height against the vehicle floor.
2. When looking at the crossmember, the center is at an angle. The upward side goes toward the front of the vehicle.
3. Install the left side bracket to the crossmember while working on the bench using the 4-3/8" bolts and tighten.
4. Install the crossmember into the vehicle. Install the right side bracket with the 4-3/8" bolts and tighten.
5. At this time, square the crossmember up with the frame and transmission and find at least two holes on each side for mounting. Use the 3/8" bolts for mounting and tighten.
6. If your trans uses a spacer, install it now, lower the trans to the spacer, and install the user supplied transmission mount bolts and tighten.
7. Once install is complete, tighten all 3/8" fasteners to 25 ft/lbs.



**Figure 1**

### **LIMITATION OF LIABILITY – DISCLAIMER:**

The regulation of emissions production, noise levels, and safety standards is undertaken by the federal government, each of the fifty state legislatures, and by many local municipalities, towns, and counties.

HOOKER™ makes no warranties of merchantability, of fitness for particular purpose, or that its products are approved for general use, or that its products comply with laws, regulations, or ordinances in the state where they may be sold to the ultimate purchaser, the consumer.

Unless expressly stated to the contrary in the catalog, instruction sheet, or price list, the entire risk as to the conformity of any company product in any such state and as to repair should the product prove to be defective or non-conforming, is on the retail purchaser, the buyer, the ultimate consumer, of such product and it is not upon the seller, distributor, or manufacturer.

In this connection, the retail purchaser, the buyer, the ultimate consumer assumes the burden of the entire cost of any and all necessary service, alterations, or repair.

### **THE FOREGOING STATEMENT LIMITS THE LIABILITY OF THE MANUFACTURER.**

California vehicle code, sections 27156 and 38391, prohibits the advertising, offering for sale, or installation of any device, which modifies a vehicle's emission control system, unless exempted, unless otherwise noted. HOOKER™ Headers that have not received an Executive Order (E.O.) exemption from these code sections are not legal for sale or use in California on vehicles originally equipped with catalytic converters, except for racing vehicles, which may never be driven upon a highway. Check with your local authorities to determine if these headers are legal for use in your particular area.

© 2019 Hooker Headers, Inc. All rights reserved. Tous Droits Réservés.

**199R11658**

**Revision Date: 9-10-20**



## 1967-72 GM C10 LS/LT Swap Engine Mounting Brackets BHS511 Installation Instructions

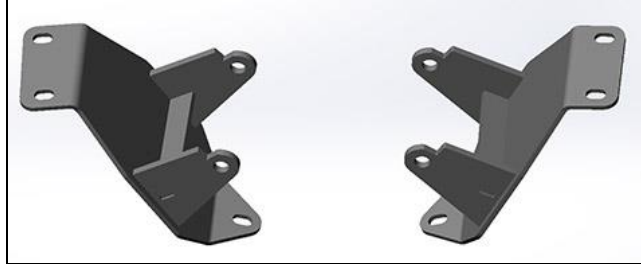

Thank you for choosing to use Hooker Blackheart engine swap mounting brackets as part of your LS swap project. These mounting brackets are part of the most comprehensively engineered system of mounting components, headers and exhaust systems available for this application. Please read these instructions thoroughly before attempting installation.

### **PRE-INSTALLATION CONSIDERATIONS:**

Installation of these brackets requires the use of new stock OE 4<sup>th</sup>-gen F-body LS engine mounts (ex: GM 22179268 or Anchor 3064) or aftermarket polyurethane inserts (Hooker BlackHeart LS/LT Polyurethane Inserts – P/N's 71221016HKR (Black) or 71221017HKR (Red) along with Hooker Blackheart 71221018HKR heavy duty clamshells or Prothane 7-512 or Energy Suspension 3-1151).

In addition, a pair of metric motor mount through-bolts and a pair of locking flange nuts will need to be sourced for connecting the Hooker engine brackets to the motor mounts. Specification requirements are 10.9 M12 x 1.75 x 140mm or Hooker Blackheart 71223015HKR engine mount bolt kit.

### **COMPATIBILITY INFORMATION:**

These LS/LT swap brackets have only been tested on 2-wheel drive applications.

This engine swap mounting bracket kit requires the use of a Holley® **302-2 and 302-3** oil pan for installation and provides compatibility with Holley accessory drive system in all spacings.

More LS/LT engine performance components, such as EFI fuel control systems, fuel filters, fuel pumps, plumbing hose/fittings, and valve covers can be found at [www.holley.com](http://www.holley.com).

### **BEFORE BEGINNING...**

Check that the hardware package includes the following:

Qty.	Description
6	3/8 x 16 x 1 Bolts
6	3/8 x 16 Nuts

If you are missing any hardware, please contact Technical Service at 1-866-464-6553 or 270-781-9741.

## **INSTALLATION:**

1. Remove the factory engine mounts from the frame and clean the bracket mounting surfaces.
2. Attach the Hooker engine mounting brackets to the frame using the supplied 3/8" hardware. Leave the hardware loose at this time.

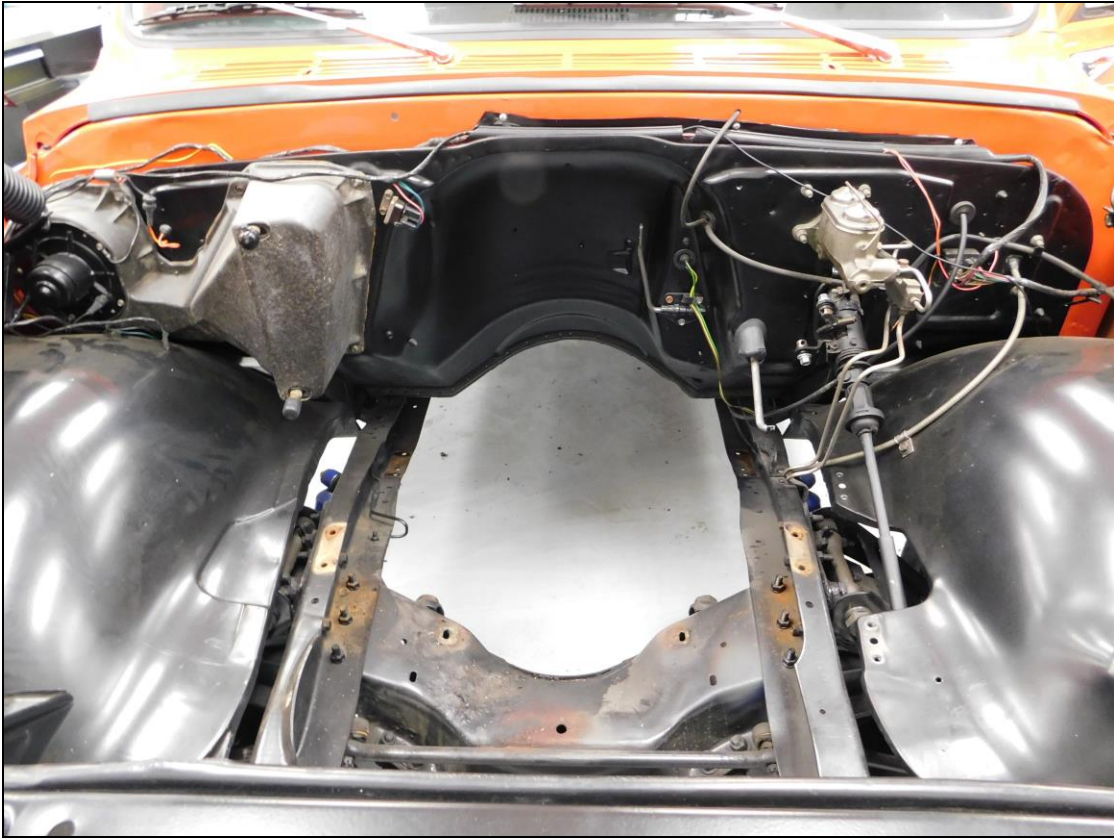

**Figure 1**

3. Install new OE rubber or aftermarket polyurethane mounts on the LS/LT engine to be installed.
4. Install the engine/transmission assembly onto the Hooker engine brackets and couple the engine mounts to the engine brackets using the Hooker Blackheart 71223015HKR engine mount bolt kit or user-sourced metric cap screws and flanged locking nuts.
5. Once the engine is sitting in the engine bay as it should, use a wrench to tighten the (x6) mounting bolts and through bolt.
6. Raise the rear of the transmission as high as it will go and install the Hooker LS/LT swap transmission crossmember per the instructions included with its packaging.
7. Your LS/LT swap engine and transmission are now mounted and ready to be outfitted with headers and an exhaust system. Hooker Blackheart LS/LT 67-72 C10 swap headers and dual exhaust systems are specifically designed for use with these engine mounting brackets.

## **LIMITATION OF LIABILITY – DISCLAIMER:**

HOOKER™ makes no warranties of merchantability, of fitness for particular purpose, or that its products are approved for general use, or that its products comply with laws, regulations, or ordinances in the state where they may be sold to the ultimate purchaser, the consumer.

Unless expressly stated to the contrary in the catalog, instruction sheet; or price list, the entire risk as to the conformity of any company product in any such state and as to repair should the product prove to be defective or non-conforming, is on the retail purchaser, the buyer, the ultimate consumer, of such product and it is not upon the seller, distributor, or manufacturer.

In this connection, the retail purchaser, the buyer, the ultimate consumer assumes the burden of the entire cost of any and all necessary service, alterations, or repair.

© 2019 Hooker Headers, Inc. All rights reserved. Tous Droits Réservés.

**199R11654**

**Date: 8-27-19**