

S7209

2018 up MUSTANG GT CAT BACK - ACTIVE
W CARBON FIBER TIPS

MBRP

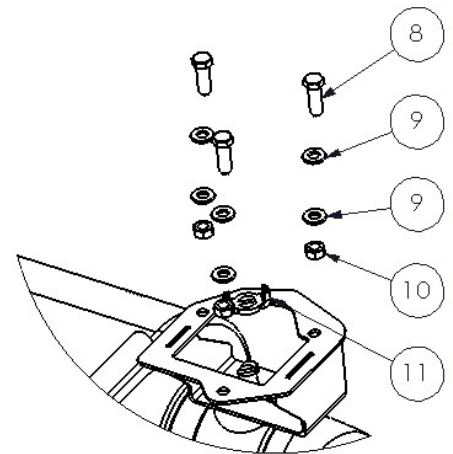
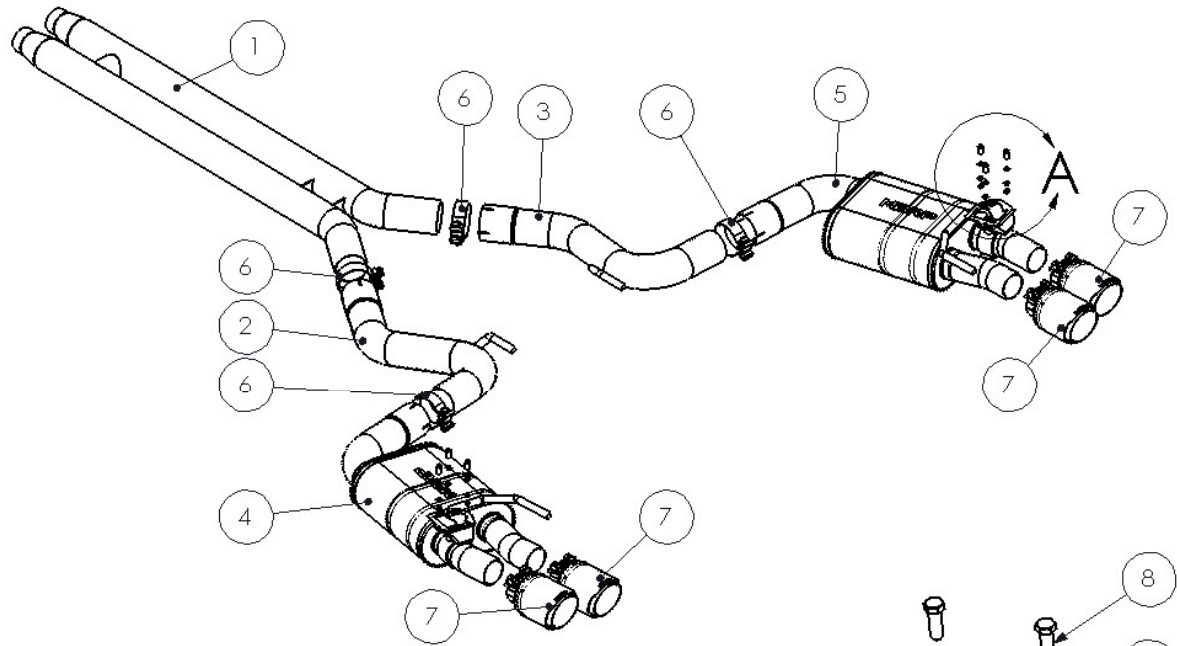

DETAIL A
SCALE 1 : 4

ITEM	DESCRIPTION	S72093CF/QTY.
1	H PIPE	1
2	DRIVER-SIDE EXTENSION PIPE	1
3	PASSENGER-SIDE EXTENSION PIPE	1
4	DRIVER-SIDE MUFFLER ASSEMBLY	1
5	PASSENGER-SIDE MUFFLER ASSEMBLY	1
6	3.0" CLAMP	4
7	TIP	4
8	M6x20 HEX BOLT	6
9	M6 FLAT WASHER	12
10	M6 LOCK NUT	6
11	SPRING HUB	2

PLEASE READ BEFORE STARTING INSTALLATION

While MBRP has made every effort to ensure that all components of this system are of superior quality and properly packaged, it is the installer's responsibility to ensure the following before removal of the factory exhaust:

- that ALL components shown above are present.
- that ALL mating components fit together.
- that there are no damaged components.
- that the system you have purchased is appropriate for your vehicle year, model and configuration.
- that the system will not interfere with any modifications previously installed or planned.
- that you have read and understand these instructions.

If you have any questions or are uncertain about any aspect of the installation of this system to your vehicle please contact your dealer before commencing installation.

Removal of Stock System



Figure 1



Figure 2



Figure 3

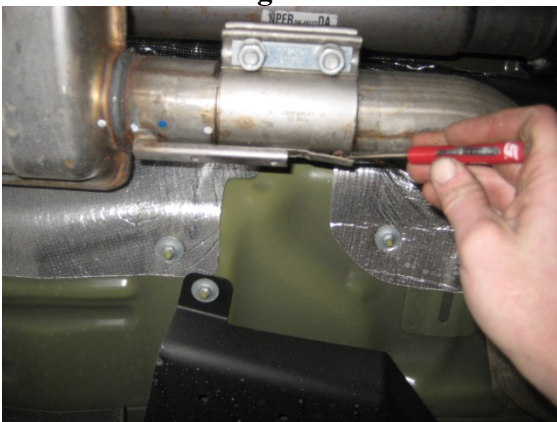

Figure 4

1. Apply a penetrating lubricant liberally to all exhaust fasteners, hangers and rubber insulators.
2. Remove the 2 piece undercar brace. [Convertible Only]
Refer to Figure 1.
3. Disconnect the exhaust valve wiring connectors located near the muffler hangers. This will leave the short wiring harness's connected to the actuators.
Refer to Figure 2.
4. Remove the M8 bolts from the mid hanger brackets and remove them from the vehicle. Retain these parts as they will be reused.
Refer to Figure 3.
5. Loosen both clamps ahead of the resonator, lift the lock tabs and slide the clamps rearward to disconnect the OEM catback exhaust. Use caution, The OEM catback is one piece and heavy.
Refer to Figure 4.
6. Remove the OEM catback by lowering the inlet end and sliding the assembly forward to remove it from the rear hangers. Remove the OEM clamps as they will be reused.
7. Unbolt and remove the rear hanger brackets. Retain these parts, they will be reused.
8. Unbolt and remove both exhaust valve actuators, wiring harnesses, and the coupling springs. Mark the actuators as driver side and passenger side for easier installation on the **MBRP Cat Back.**



Figure 5

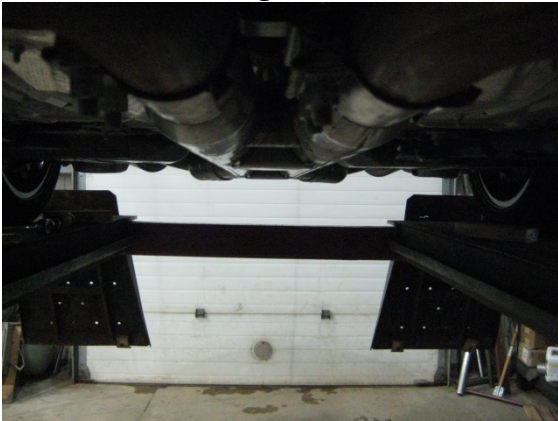

Figure 6



Figure 7



Figure 8

Installation of MBRP Performance Exhaust

1. Install the previously removed clamps onto the inlets of the **H Pipe** and install the assembly onto the vehicle with the flat side of the pipe support bracket facing the ground. Tighten the clamps enough to allow for adjustment while ensuring the **H Pipe** is level as viewed from the rear of the car.

Refer to Figures 5 and 6.

2. Install a **3" Clamp** onto each of the **H Pipe** outlets. Install the mid hanger bracket onto the **Driver-Side Extension Pipe** before installing it onto the outlet of the **H Pipe**. Install the mid hanger bracket on the vehicle and secure with the previously removed M8 bolt. Tighten the **3" Clamp** enough to allow for pipe alignment.

Refer to Figure 7.

3. Install a **Spring Hub** onto the shaft of the exhaust valve on the **Driver-Side Muffler Assembly**.

Refer to Figure 8.

4. Install the driver side OEM valve actuator onto the **Driver-Side Muffler Assembly** being sure the lower legs of the coupling spring engage the notched legs of the **Spring Hub**. Secure the actuator using the supplied **M6x20 Hex Bolts, M6 Flat Washers, and M6 Lock Nuts**.

5. Install a **3" Clamp** onto the outlet of the **Driver-Side Extension Pipe**. Install the rear hanger bracket onto the **Driver-Side Muffler Assembly** before installing it onto the outlet of the **Driver-Side Extension Pipe**. Secure the rear hanger bracket with the previously removed M8 bolts. Tighten the **3" Clamp** enough to allow for pipe alignment.

6. Repeat steps 3-5 for the passenger side components.

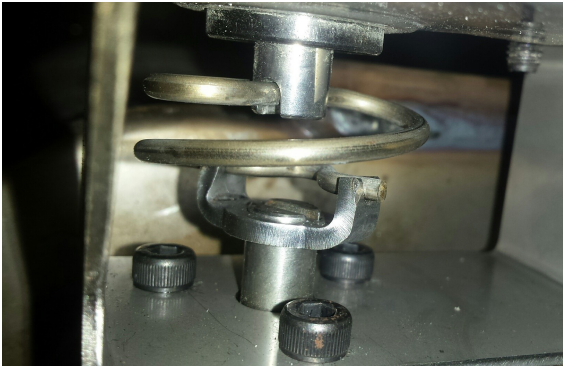

Figure 9



Figure 10

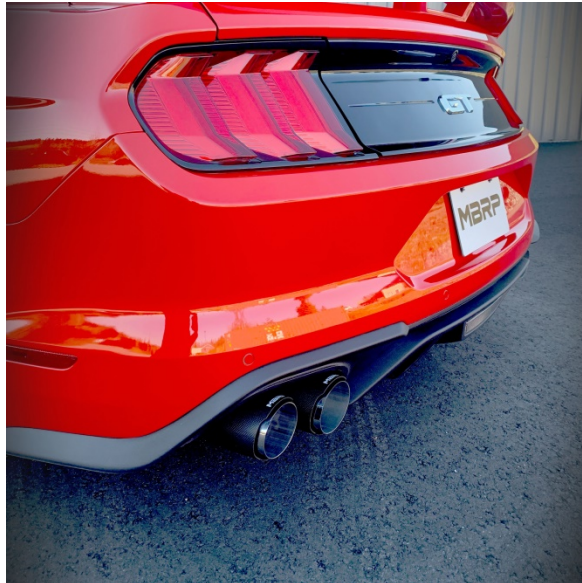

Figure 11



Figure 12

7. Re-connect both exhaust valve actuator wiring harnesses.
8. Install the **Tips** and tighten just enough to allow for alignment. **Refer to Figure 12.**
9. Install the undercar brace [Convertible Only] using the previously removed hardware. Note some pipe modifications may be required to provide clearance.
10. Align the exhaust as required to center the **Tips** in the rear fascia, and provide clearance around all other undercar components, then tighten all clamps.
Note; The mid hanger brackets can be used to help center the **Tips** in the Fascia. Once all clamps are tight, adjust the mid hanger brackets to fine tune the placement of the **Tips** then tighten the M8 bolts.
11. Check along the whole length of the exhaust system to ensure that there is adequate clearance around fuel and brake lines or any other components. If any interference is detected relocate or adjust.



Congratulations! You are ready to begin experiencing the improved performance and driving pleasure of your MBRP performance exhaust system. We know you will enjoy your purchase.