



DBF48

**Disc Conversion Kit for Front Axles from
AMC/Jeep, CJ-5, CJ-6, CJ-7, C101, Jeepster
Cherokee and Wagoneer**

DANA 25 1953-1970

DANA 27 1953-1973

DANA 30 1966-UP

Ford Bronco 1966-1971 DANA 30

**** Early Broncos require hub modification ****

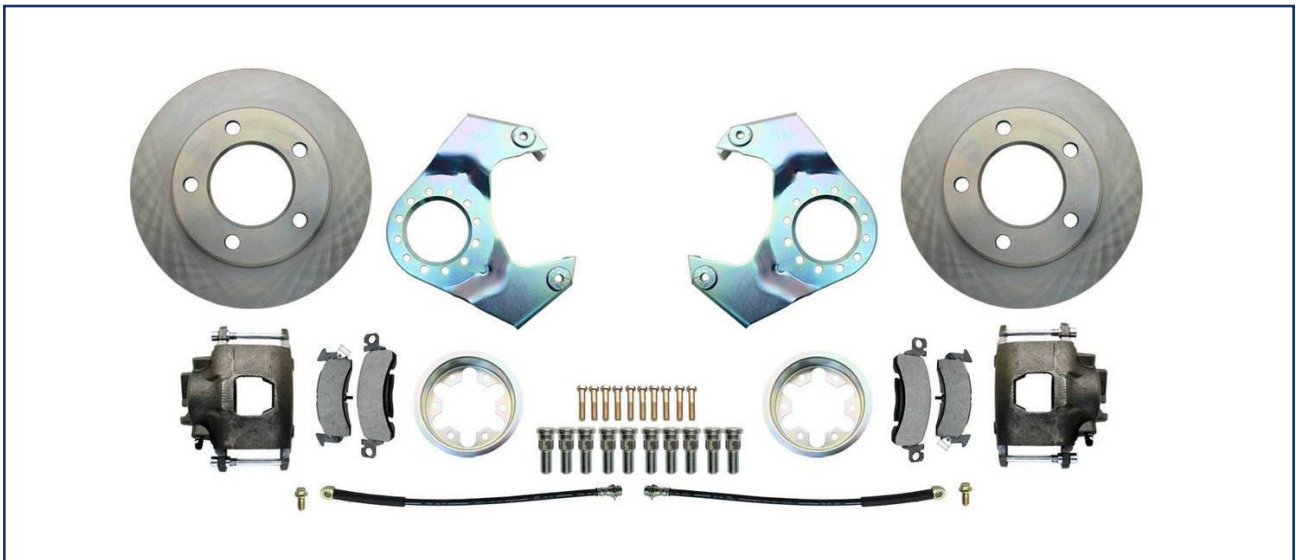

Parts Included:

Qty 2 of the following: Rotors, Calipers with pads, Caliper Mounting Brackets, Dust Shields, brake hoses
Qty 10 ~ 1/2"-20 Lug Studs

This kit is AVAILABLE IN high PERFORMANCE package with stainless steel hoses and drilled rotors
Note: Always refer to the vehicle owner's manual for torque specifications when installing kit.

NOTE * THIS KIT USES THE ORIGINAL DRUM SPINDLES AND HUB ASSEMBLIES

Be sure to handle your hubs with care when disassembling them and do not hammer on the hubs themselves

Preparing for disassembly:

1. Place the truck on jack stands.
2. Remove the front wheels.
3. Drain the master cylinder (plan to replace it according to disc/drum vs disc/disc)
4. Place catch pan below the front wheels and disconnect the front flex hoses to the wheel cylinders.
5. Remove the locking hub mechanism, and set parts aside in order.
6. Proceed to removing the hub itself.

Removing the hubs:

The components of the Jeep and Bronco hubs are different. The steering knuckle, spindle nuts, hub unit and locking hubs are similar objects, but are manufacturer specific and are not shared. We have exploded views of each type below. To install the kit, both use a specific spindle nut socket tool.

Jeep hubs

7. Below is the exploded view of the DANA 30 for the Jeep.
It consists of: Hub Cap, the lock washer, nuts and studs, Inner Wheel Bearing, Wheel Hub, Outer Wheel Bearing, Lock washer, Wheel Bearing, Nut, Wheel Bearing, Lock washer, Wheel Bearing Nut, Drive Flange Gasket, Axle Drive Flange, Snap Ring, Hub, Wheel Bearing Spindle, Brake Mounting Nuts, and the grease seal.
8. Pay special attention to the order of the components since you will be reassembling them in the same order. Inspect these parts for damage and replace as necessary.
9. Set all of the locking hub components and all of the hub mounting parts together for reassembly. However, you will be discarding the entire drum backing plate and shoe system. (not shown below)

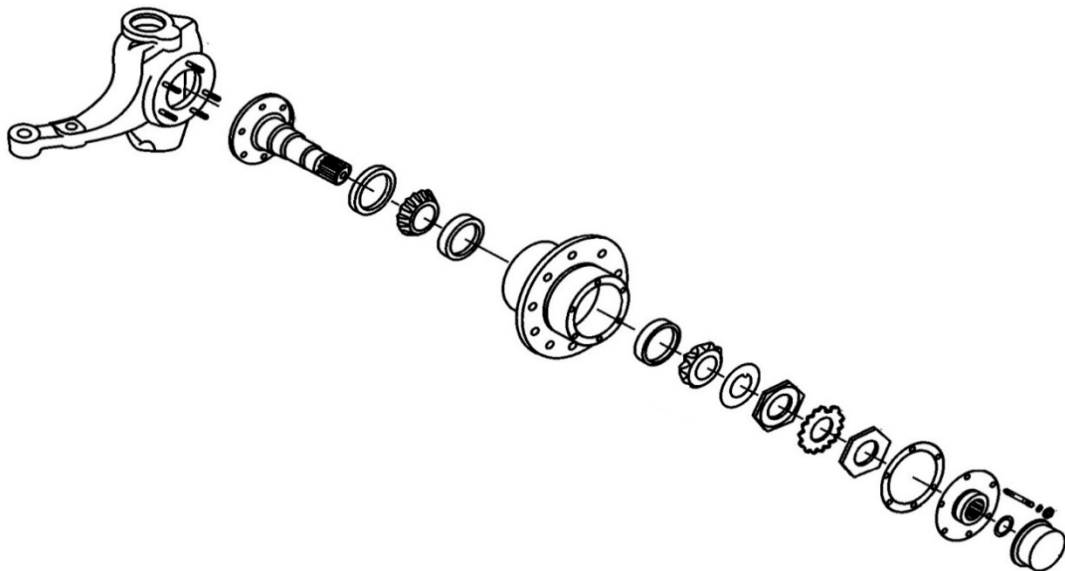

Bronco hubs

10. Bronco owners will need the Dana 30 Front End Bearing Spindle Nut Socket Tool for removing & installing the spindle nuts. The tool is 4 prong and 2 3/8".
11. Remove the following parts located in the hub unit: dust cap, snap ring, axle drive gear, pressure spring, spring retainer plate, wheel bearing adjusting nut, lock nut, inner lock nut pin assembly, outer wheel bearing, hub assembly, inner wheel bearing and the grease seal.
12. Pay special attention to the order of the components since you will be reassembling them in the same order. Inspect these parts for damage and replace as necessary.
13. Set all of the locking hub components and all of the hub mounting parts together for reassembly. You will be discarding the entire drum backing plate and shoe system. (not shown below)

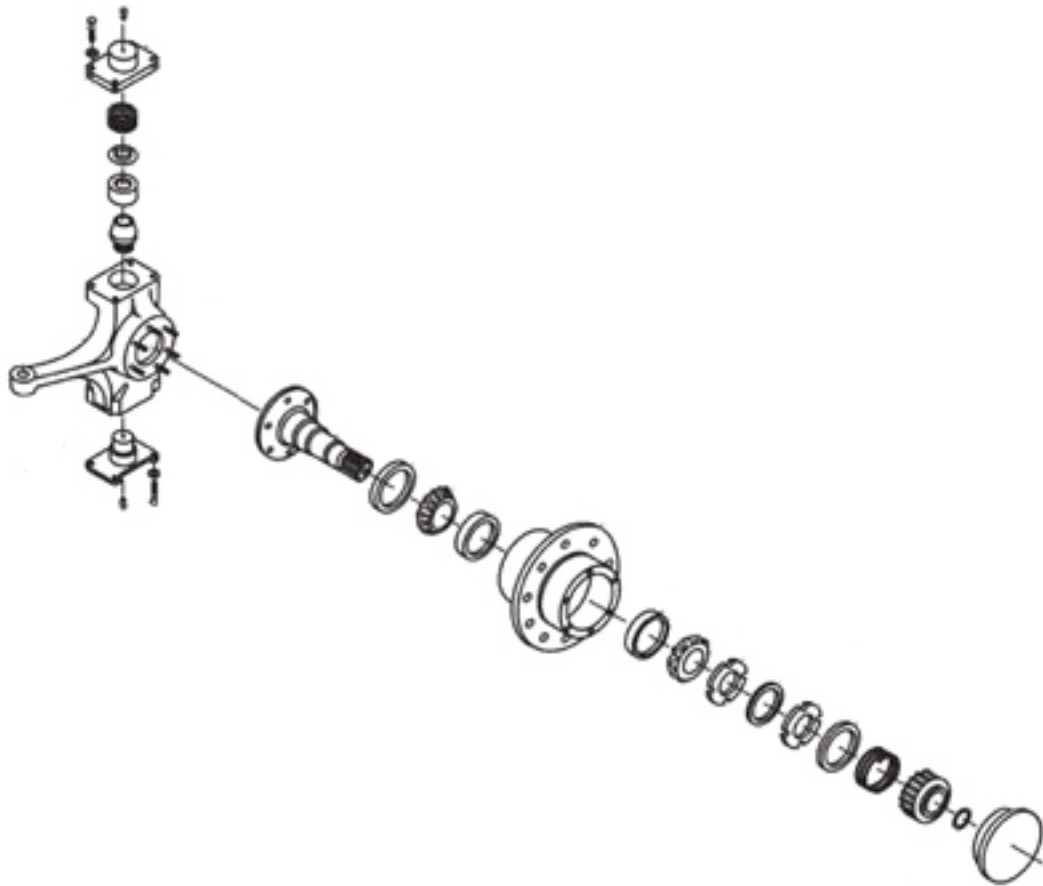

Removing the brake drum-Bronco and Jeep

14. Remove the brake drums from the spindles by relaxing the adjusting levers with a spoon tool.
15. Remove the drum backing plates by removing the 6 bolts. (Shown above in picture on the right.)
16. In order to mount the caliper bracket and rotors, you will need to remove the drum backing plates.
17. While the unit is taken apart, you may want to remove the spindle and check the bearings and grease seal. Removing the spindle from the knuckle may require a puller. You don't want to damage it.
18. Consider replacing the bearings, hubs or seals if there are any signs of damage or leaking or if you are experiencing road noise from the bearings.
19. Also check the differential gasket for signs of leaking and check the fluid level.
20. The caliper brackets in this kit are not side specific.
21. Clean the face of the drum spindle and make sure the threaded holes are clear of debris.
22. If any of the holes or the bolts that you removed have stripped threads, run a 3/8"-24 tap into the holes and blow out any debris.
23. Mount the caliper bracket with the six 3/8"-24 bolts and lock washers provided on the axle flange.
24. The bracket should be positioned so the caliper is in the trailing position, away from the control arms.
DANA 30 caliper locations: **Driver Side** -3 o'clock, **Passenger side** -9 o'clock.
DANA 44 caliper locations: **Driver Side** -2 o'clock, **Passenger side** -10 o'clock.
25. Torque down the 6 caliper mounting bolts to the 40 Ft. Lbs.



Preparing the Hub to accept the new rotor location and fitment

****THIS KIT USES THE ORIGINAL DRUM SPINDLES AND HUB ASSEMBLIES****

Jeep Owners:

You will be removing the old wheel studs, cleaning up your hub, inspecting the flange on the hub where the new rotor will mount, test fitting the rotor against the back side of the hub, replacing the wheel studs, replacing bearings, seals and adding fresh grease.

Bronco Owners: Be aware you will have to modify the hubs to install the rotors.

You will be removing the old wheel studs, cleaning up your hub, inspecting the flange on the hub where the new rotor will mount, and taking the hubs to a machine shop before replacing the wheel studs, bearings, seals and adding fresh grease.

The hubs on Broncos need to have the inward facing section of the hub machined down to 3.748" and the flange thickness must be reduced to 0.460".

In the picture below, you can see where the original profile on the hub will not allow the rotor center hole to fit down all the way. It has to be turned down.

26. Once your hub has been machined down to the dimensions shown below, you can proceed.
27. Knock the original drum studs out of the hubs. You will use the new ½"-20 studs provided in this kit.
28. The best way to remove the old wheel studs is with a press. If you want to knock them out with a hammer, you need to block up the flange face so you don't warp it. Remember the rotor must seat flat against it.

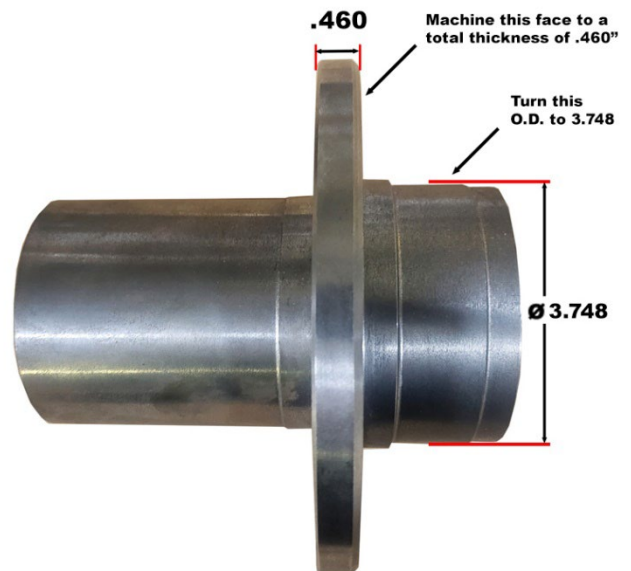

Maintain Tolerance of .005"

29. **IMPORTANT**...The rotor will be mounted on the back or inside of the hub's flange. In other words, the drum rested against the outer face, whereas the rotor rests against the inner face.

30. Next you need to attach the wheel studs to the new rotor and then through the hub.

31. Inspect the rear face of the hub for imperfections. You can use a straight edge to check.

32. Grind all surfaces on the back face of the hub even so the new rotor rests true on it.

33. Now that the rotor has been test fitted against the rear face of the hub, proceed to assembling.

Assembling the hub - Bronco and Jeep

34. So, from the back side of the hub less rotor, insert the new wheel studs through the rotor itself and drive them into the back side of the hub using a punch or use a press. Another way is to place several washers over the studs and use a lug nut and impact gun to draw them through.

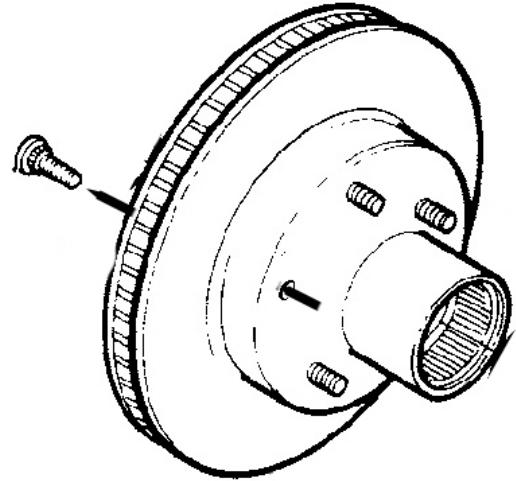

35. The new rotor is held to the hub from the back side by the wheel studs. It should look like this.



Bronco Spindle lock nut installation

36. Locate your inner bearing and pack the bearing with wheel bearing grease.
37. Apply grease to the inner race and place the bearing in the hub.
38. Install the inner grease seal into the hub
39. Coat the seal with grease. It is ready to install onto the spindle.
40. Put grease on the spindle shaft and where the seal will be once the hub is placed there.
41. Place the hub assembly on to the spindle.
42. Grease the outer bearing and place it into the hub resting on the spindle.
43. Next locate the 2 spindle lock nuts and washer.
44. Install the one with the dowel pin with the pin facing towards you so you can see it.
45. Use the 4 prong tool to tighten it. Tighten it so that the rotor is snug and it doesn't wobble. Now, back it off slightly, & retighten hand tight. Test spin the rotor.
46. Next place the spindle nut washer onto the nut with the dowel pin. Make sure one of the holes lines up with the dowel pin. The washer should be flat against the nut.
Install the second spindle lock nut and tighten it down using the 4 prong tool. Torque the spindle nut to 60Ft. Lbs. Test spin the rotor.

Jeep Spindle lock nut installation

47. Complete the hub assembly and make sure to pack the outer wheel bearings with grease.
48. Install the inner spindle lock nut using the 4wd **Jeep spindle nut tool**.
49. Install the spindle nut lock washer by placing the alignment tooth in the slot. Install the second spindle lock nut with the 4wd **jeep spindle nut tool**. Torque the spindle lock nut to 60 Ft. Lbs.
50. Install the 4wd locking hub mechanism.
51. Test spin the rotors.
52. Double check all bolts

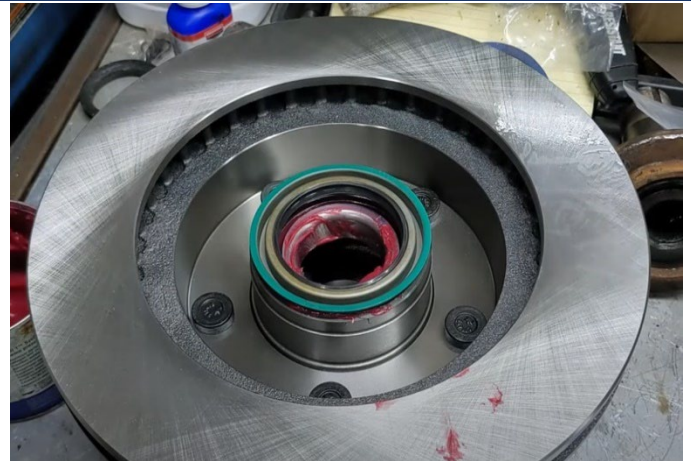

Mounting the calipers-Bronco and Jeep

Below are images of the Bronco & Jeep Hub unit designs. There may be variations in the locking ends based on which brand you are installing. Consult that manufacturer for tech drawings and installation instructions.

53. Locate the calipers, adjust the slide pins sleeves and mount the calipers in the brackets.
54. Be sure to mount the calipers (without pads inserted) with the bleeder screws facing up.
55. Push the caliper back and forth on the slides to check for unwanted contact with the knuckle.

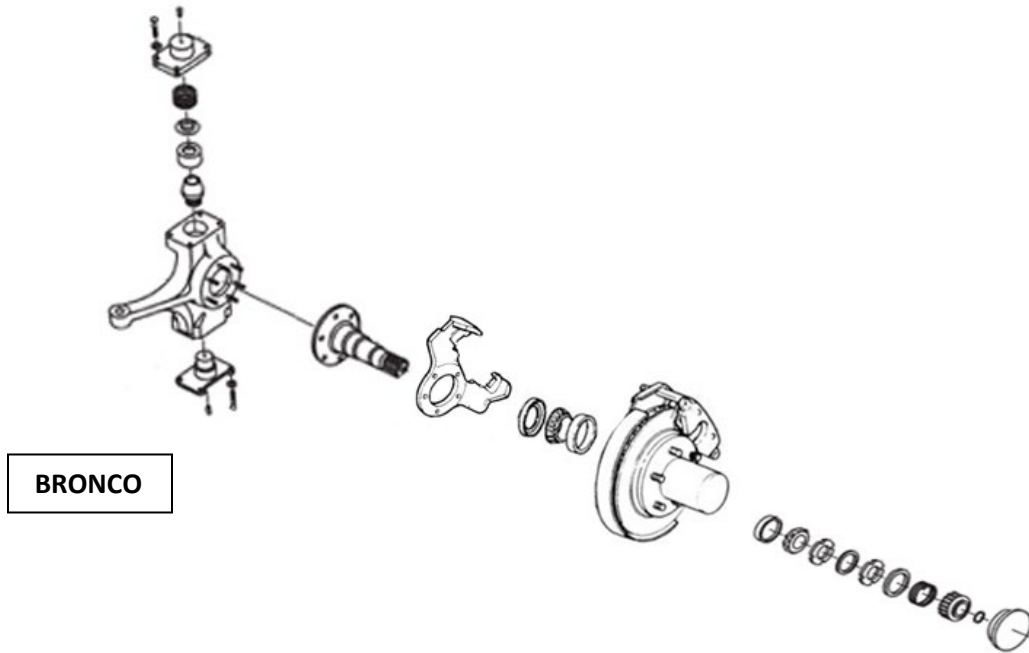

BRONCO

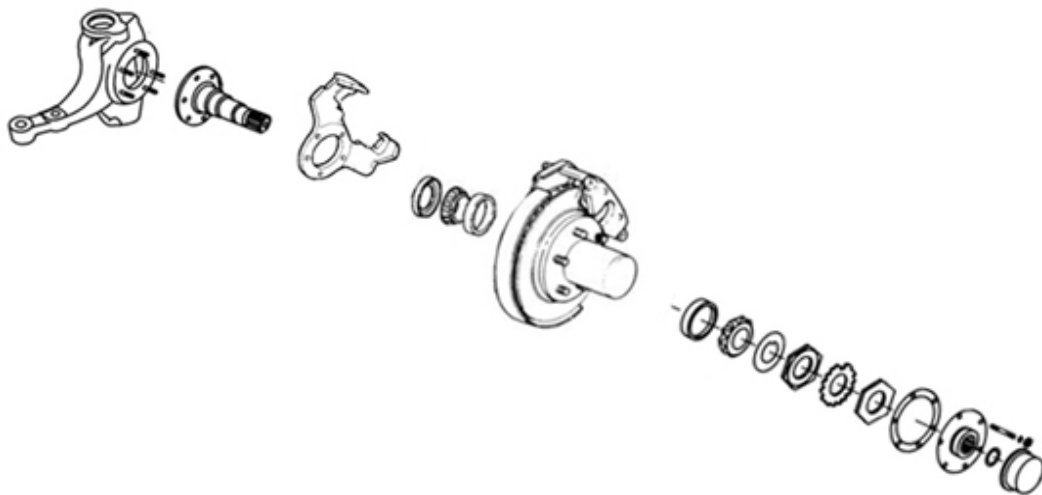

Jeep

56. You may need to grind on the steering knuckle or calipers for additional clearance. Test fitment by turning the steering lock to lock. Make sure you have 1/8" clearance between the caliper and steering knuckle.

57. Verify that there is nothing restricting the turning radius. Grind slowly.

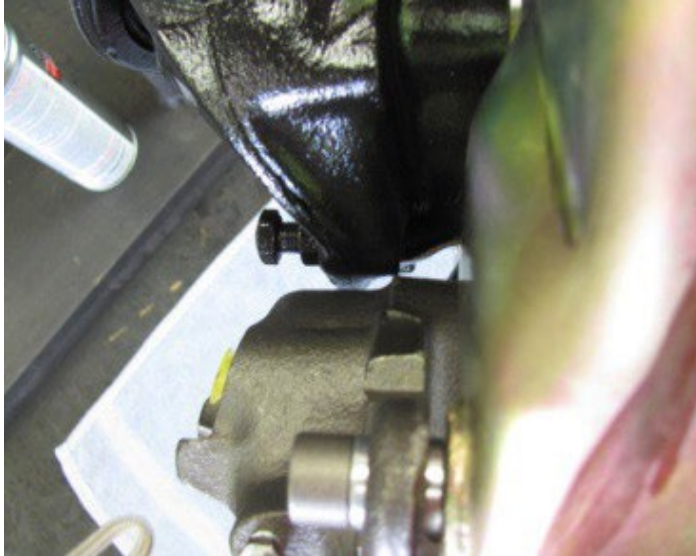

58. Do a final clearance check.

59. Insert pads with disc brake quiet and lube the caliper slides.

60. Torque caliper bolts to 25 Ft. Lbs.

61. Connect brake hoses. Hand tighten the banjo bolts for now.

62. Place copper crush washer on both sides of the banjo bolts.

63. Turn the steering wheel to decide final brake hose positioning, then tighten the banjo bolts.

64. Be sure to clean the rotors with brake cleaner before bleeding the brakes.



65. There may be variations in the locking hub ends based on which brand you are installing. Consult that manufacturer for tech drawings and installation instructions.
66. Install the locking hub mechanism and complete the final assembly. **Refer to your preferred locking hub manufacturer's manual to complete the installation.**

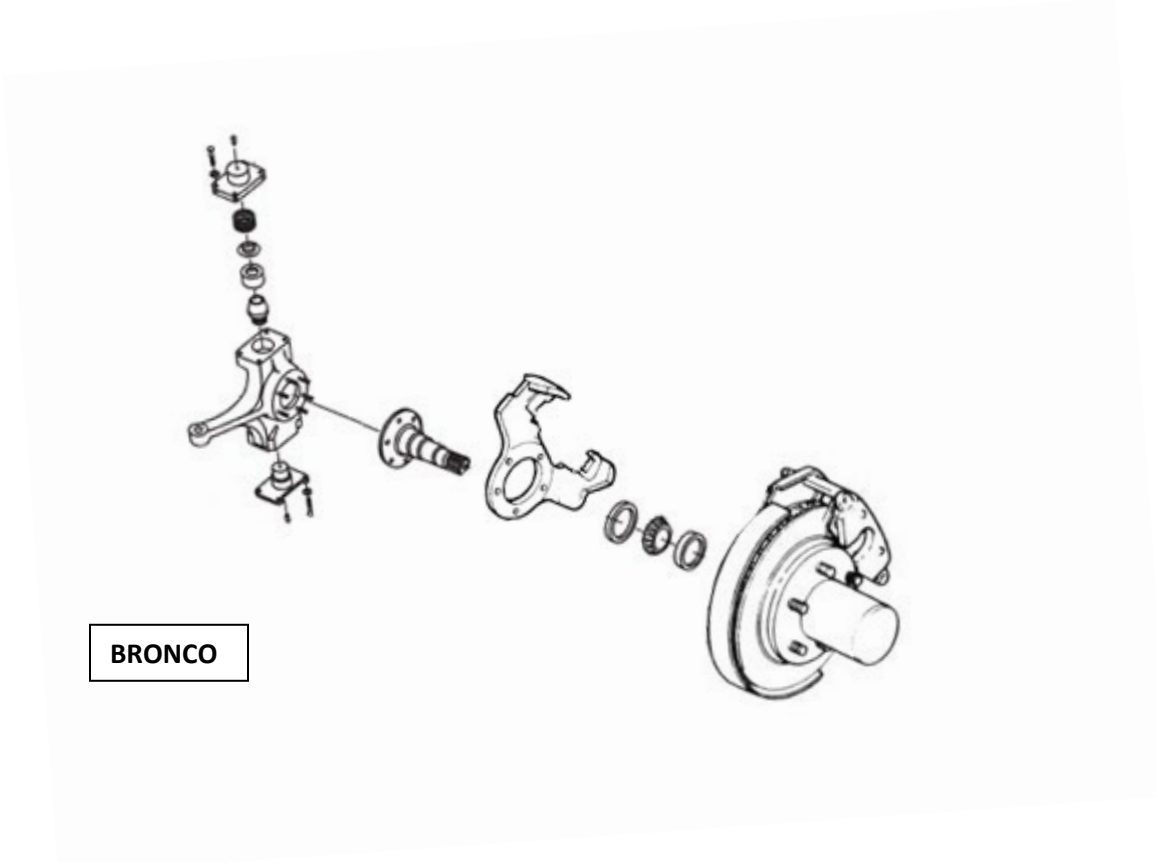

BRONCO

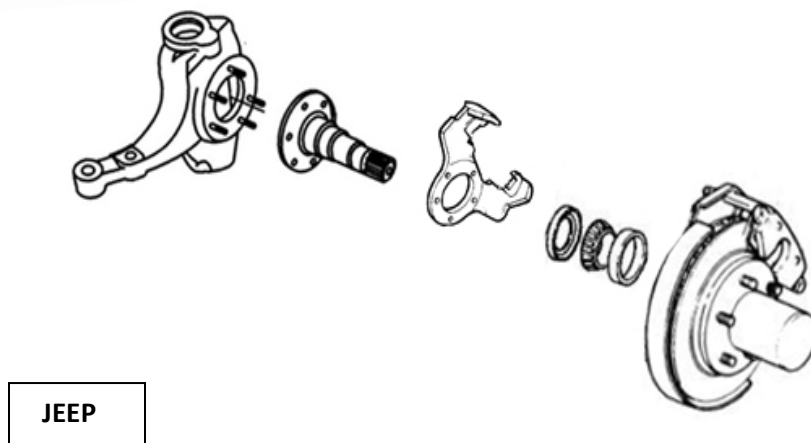

JEEP

67. Proceed to bleeding your brakes.
68. Bleed brakes in order furthest away from the master cylinder. Rear right, rear left, front right, front left.
69. Test your brakes in a safe location.