



Detroit Speed, Inc.
ALUMA-Frame LS Engine Mount Kit
P/N: 060423
Installation Instructions

Thank you for your purchase of the Detroit Speed Adjustable ALUMA-Frame LS Engine Mount Kit. This kit will enable you to easily bolt-in late model LS Engines into your ALUMA-Frame. It will locate the crank centerline, and engine mounting angle (3° down in the rear measured from the crank centerline) of your LS Engine in the same position as the stock engine. The bellhousing mounting surface will be located 1-1/2" rearward of the original engine location for oil pan clearance and improved weight distribution.

Description	Quantity
LS Engine Mount Bracket, Left	1
LS Engine Mount Bracket, Right	1
M10 X 1.5 X 25mm Flanged Hex Cap Screws	8
Adjustable Engine Mount Isolator Assembly	2
3/8"-16 X 1-1/2" Hex Cap Screw	4
3/8" SAE Flat Washer	4
3/8"-16 Hex Flange Locknut	4

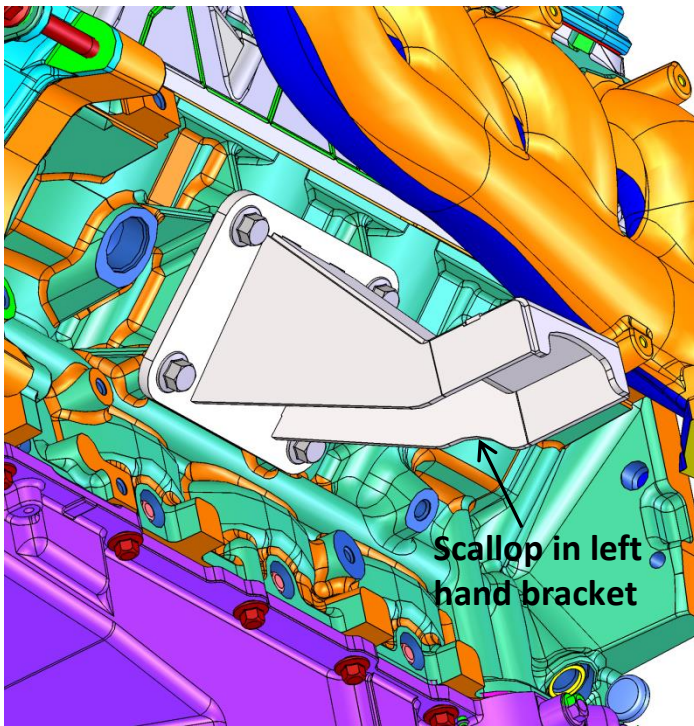

Figure 1: Left Hand Bracket Installation

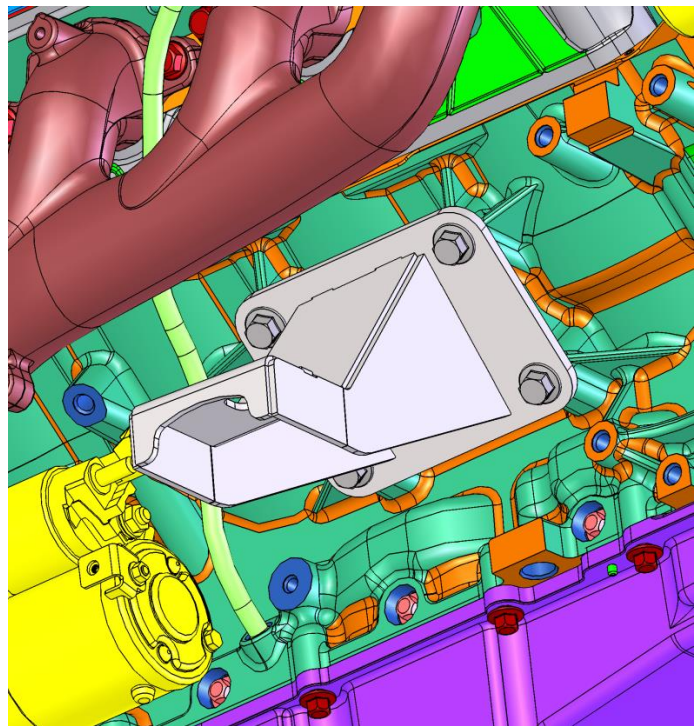

Figure 2: Right Hand Bracket Installation

Install the left and right hand engine mount brackets to the block with the provided M10 flange bolts as shown in Figures 1 and 2 using a medium strength threadlocker (Loctite 242 or equivalent) on the threads. The left hand bracket can be identified by the scallop that is cut out of the rear flange. Torque the bolts to 30 ft-lbs. Refer to the ALUMA-Frame Adjustable Engine Mount Isolator Kit Instructions for their installation.

The Aluma-Frame adjustable engine mount isolators are designed to minimize the transmission and drivetrain vibrations while providing secure mounting for your engine. They are adjustable in 1/4" increments from 1/4" higher than standard height to 1" lower.

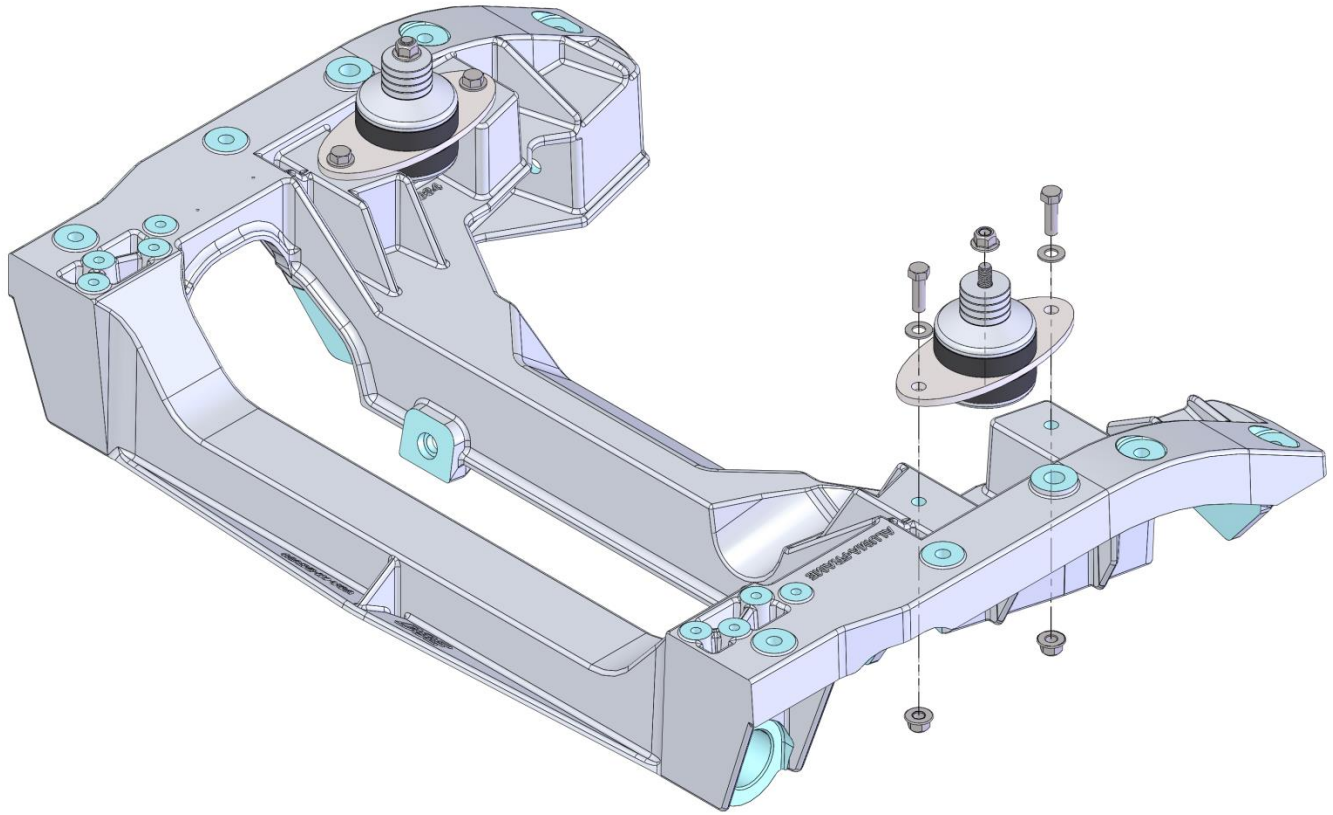

Figure 1

Install the Engine Mount Isolators on the ALUMA-Frame with the provided 3/8" bolts, washers, and locknuts as shown in Figure 1 and torque to 30 ft-lbs. Once the engine is installed, torque the M10 locknuts on the isolator assemblies to 30 ft-lbs.

Engine Mount Adjustment

If the mounts are going to be used in conjunction with a Detroit Speed engine mount kit it is recommended that the isolators remain at the standard height (Figure 2). All Detroit Speed engine mount kits are designed for the engine mount isolators to be installed at the standard height. For some custom installations, the engine mount height can be adjusted if needed.

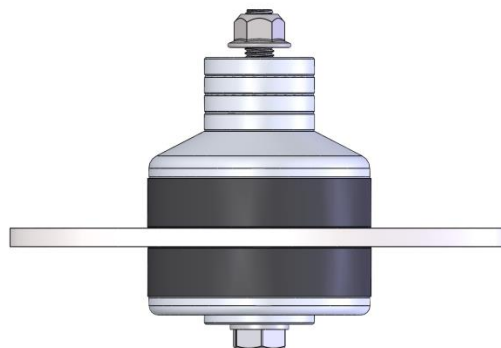

Figure 2: Standard Height-Four spacers on the top and one spacer on the bottom.

To Lower the Engine: In order to lower the engine height, remove the desired number of spacers from the engine mount isolator assemblies (see Figure 3). Each spacer is 1/4" tall, so the engine can be lowered up to 1" in 1/4" increments.

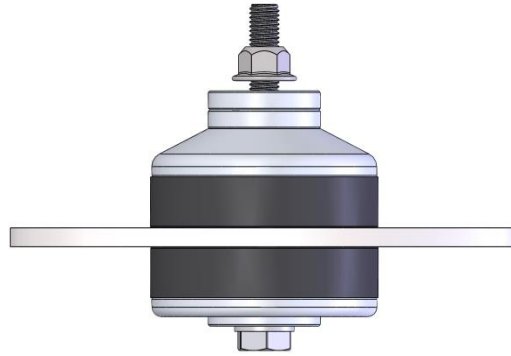

Figure 3: Two top spacer's removed-1/2" lower.

To Raise the Engine: In order to raise the engine, the 1/4" spacer at the bottom of the mount needs to be moved to the top resulting in a 1/4" increase in height (see Figure 4). Disassemble the mount by holding the top cap with a spanner wrench or other suitable tool and loosen the M10 bolt on the bottom of the mount. Remove the 1/4" spacer from the bolt and then reassemble the mount. Torque the bolt to 30 ft-lbs. Add the spacer that was removed from the bottom of the mount to the stack of spacers on the top of the mount.

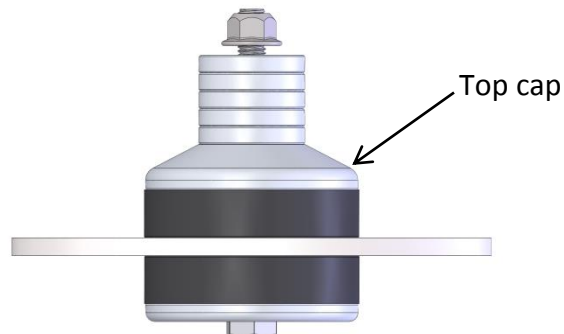

Figure 4: Bottom spacer moved to top-1/4" higher.

Thank you for your purchase. If you have any questions please call Detroit Speed at (704) 662-3272.