

13134 Installation Instructions

WARNING!

The fuel system is under pressure. Do not open the fuel system until the pressure has been relieved. Refer to the appropriate vehicle service manual for the procedure and precautions for relieving the fuel system pressure.

NOTE: Testing the enclosed regulator by applying air pressure or vacuum to the vacuum port with a hand-held pump will yield poor results, due to the slight air leakage through the adjustment screw threads. This minute leakage, which is typical of all adjustable fuel pressure regulators, does not, in any way, affect the performance of the regulator.
The enclosed regulator will not necessarily seal to hold fuel pressure after the fuel pump stops running.

The enclosed Aeromotive regulator utilizes 2 o-ring sealed AN-10 ORB style inlet/outlet ports, and one o-ring sealed AN-10 style ORB bypass port. This requires ORB-10 to AN male-flare port fittings to be used, such as Aeromotive P/N 15608 or equivalent. These regulator ports are **NOT PIPE THREAD** and the fittings utilize **NO THREAD SEALANT**.

The enclosed Aeromotive regulator is designed to be used with high flow, high pressure, electric fuel pumps similar to Aeromotive' Eliminator P/N 11104 or larger (bypass flow between 180-300 GPH). Ideal for Dual A1000 systems. Bypass restriction measures 5/16" or 0.313" on the ID.

The Vacuum / Boost reference port is provided for fuel pressure compensation on a 1:1 ratio with manifold pressure (vacuum or boost) in PSI. This port must be connected to the intake manifold, in the plenum (behind the throttle body) for proper vacuum/boost reference.

CAUTION:

Installation of this product requires detailed knowledge of automotive systems and repair procedures. We recommend that this installation be carried out by a qualified automotive technician.

Installation of this product requires handling of gasoline. Ensure you are working in a well ventilated area with an approved fire extinguisher nearby. Extinguish all open flames, prohibit smoking and eliminate all sources of ignition in the area of the vehicle before proceeding with the installation.

When installing this product, wear eye goggles and other safety apparel as needed to protect yourself from debris and sprayed gasoline.

Aeromotive system components are not legal for sale or use on emission controlled motor vehicles.

Aeromotive Commonly Used Fittings

15608 ORB-10 to AN-10 Male Flare (Inlet & bypass AN-10)
15610 ORB-10 to AN-08 Flare (Inlet fitting only AN-08)
15609 ORB-10 to AN-06 Flare (Inlet fitting only AN-06)
15642 ORB-10 to AN-12 Flare (Inlet & bypass AN-12)

** 15619 1/16" NPT to AN-04 Vac/Boost port adapter
** 15630 1/16" NPT to 5/32" Barb Vac/Boost port adapter
15662 1/16" NPT to Bronze Filter/Breather

** Included with Regulator

Aeromotive Regulator Specifications

2x ORB-10 Inlet/Outlet Ports
1x ORB-10 By-pass Ports
1x 1/16" NPT Vacuum/Boost Port
1 ea. 5/32" Hose barb and AN-04 Vacuum/Boost Adapters
0.313" (5/16-inch) Diameter Bypass Restriction
Spring #1 30-75 psi (Factory installed in regulator)
Spring #2 75-120 psi

The following steps are typical of most installations:

1. Once the engine has been allowed to cool, disconnect the negative battery cable and relieve the fuel system pressure.
2. Remove the vacuum line from the existing regulator, if equipped (some vehicles do not have vacuum operated regulators).
3. Place shop towels around the regulator to catch any gasoline that is spilled during this step of the installation. Remove any regulator mounting hardware and connecting fuel lines, then carefully remove the regulator.
4. Find a suitable place in the vehicle's engine compartment to mount the Aeromotive regulator. Using the supplied mounting bracket as a template, mark the bracket mounting holes to the mounting surface and drill to accept a #10 screw.
5. With the bracket attached to the regulator, mount the bracket and regulator to the vehicle using two #10 screws, nuts and lock washers.
6. Attach supply line(s) using high-pressure AN line to the ORB-10 inlet ports located on either side of the regulator. Use ORB-10 to AN male port fittings with o-rings. Block any unused supply ports using an ORB-10 port plug and o-ring.

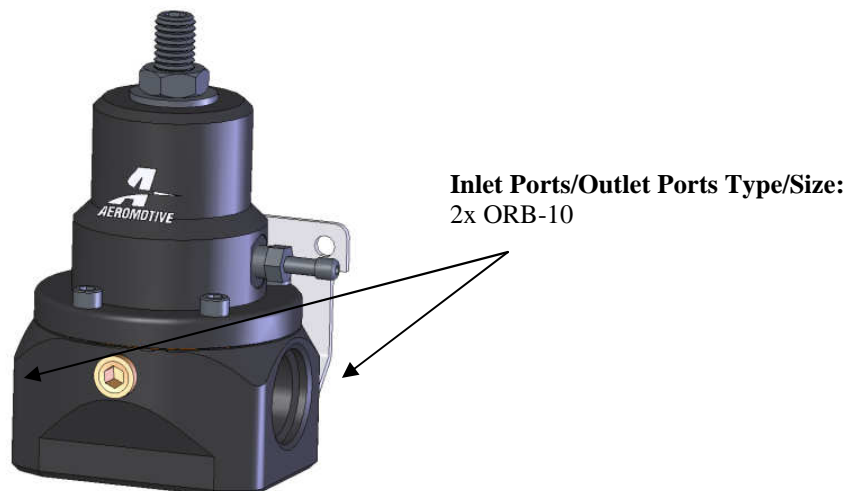

- Attach the fuel return line to the ORB-10 bypass port located at the bottom of the regulator using a ORB-10 to AN-10 port fitting (Aeromotive P/N 15608 or equivalent) and o-ring.

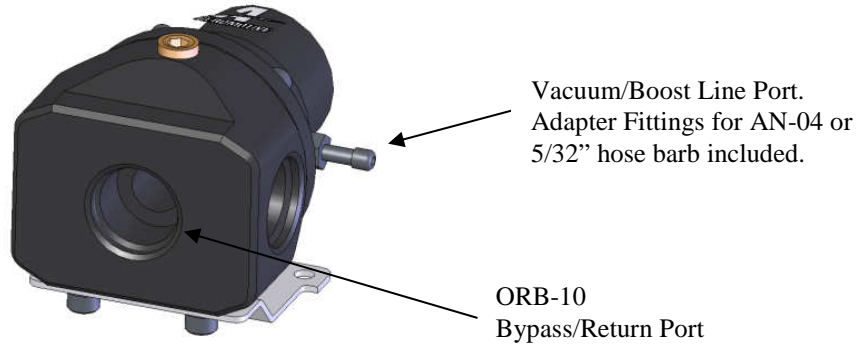

Figure 1-1 is optimum for performance V8 engines with duel fuel rails, offering both inlet and outlet ports.

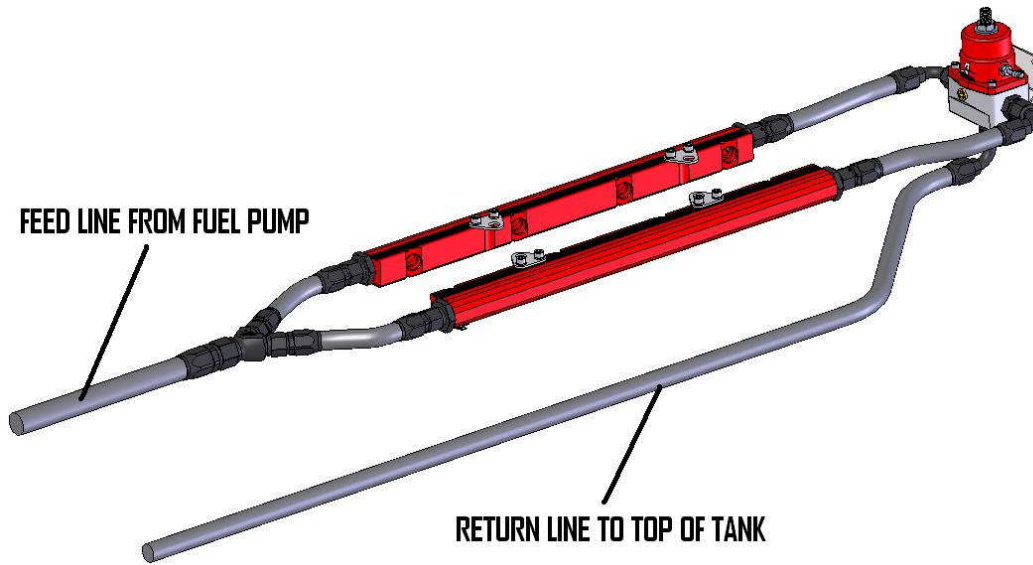

FIGURE 1-1

Figure 1-2 is typical for single fuel rail engines equipped with both inlet and outlet ports. Multiple fuel rails may also be plumbed in this fashion, either "in series" or "in a horse-shoe". Note: Multiple fuel rails are always best plumbed in parallel (as in Figure 1-1 above) for best flow and pressure control.

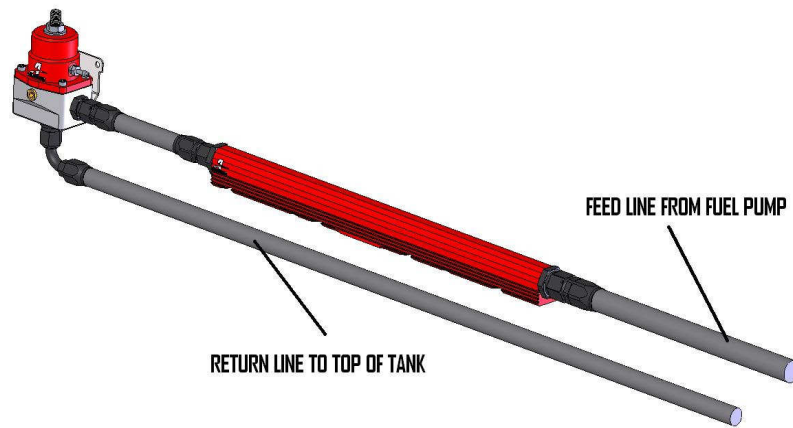

FIGURE 1-2

10. Once the regulator is installed, attach a suitable fuel pressure gauge to the 1/8 NPT port on the fuel pressure regulator (0-100psi 1.5" fuel pressure gauge, part # 15633). Requires thread sealant.
11. **Ensure that any spilled gasoline and any gasoline soaked shop towels are cleaned up and removed from the vicinity of the vehicle!**
12. Reconnect the battery and turn the ignition to the ON position **WITHOUT** starting the car. After several seconds, check the fuel pressure. If there is no fuel pressure, turn the ignition key to the OFF position, wait one minute, return the ignition to the ON position, and recheck the fuel pressure. Repeat this ignition OFF and ON procedure until the fuel pressure gauge registers fuel pressure.
13. **With the fuel pressure gauge registering fuel system pressure, check for fuel leaks from and around the Aeromotive regulator and all fuel lines and connections near the regulator! If any fuel leaks are found, turn the ignition key to the OFF position, remove any spilled fuel and repair the leak before proceeding!**
14. Once the fuel pressure gauge registers fuel system pressure and there are no fuel leaks, start the engine and adjust the regulator to the desired fuel pressure. Turning the adjustment screw clockwise will increase fuel pressure. OEM regulators are typically set at approximately 43 psi, without the vacuum line attached. The fuel pressure adjustment range for the enclosed regulator is 30-75 psi with the factory installed spring and 75-120 with the optional spring installed.
15. Once the desired fuel pressure is achieved, tighten the jam-nut on the adjusting stud and attach the vacuum/boost line if the vehicle has one. The vacuum/boost port may be left open to atmosphere by using a breather, (part #15662). Blocking the vacuum port will yield poor regulator performance. This regulator includes vacuum/boost fittings for both AN-04 and 5/32" hose barb. Replacement fittings can be purchased under p/n 15619 for AN-04, or p/n 15630 for 5/32" hose barb.
16. If you wish to remove the fuel pressure gauge from the vehicle, **FIRST** relieve the fuel system pressure as instructed in the appropriate vehicle service manual, then remove the fuel pressure gauge and reinstall the 1/8-NPT port plug.
17. Test drive the car to insure proper operation and re-check the fuel system for leaks. **If any leaks are found, immediately shut off the engine and repair the leak(s)!**

AEROMOTIVE, INC. LIMITED WARRANTY

This Aeromotive Product, with proof of purchase dated on or after January 1, 2003, is warranted to be free from defects in materials and workmanship for a period of one year from the original date of purchase. No warranty claim will be valid without authentic, dated proof of purchase.

This warranty is to the original retail purchaser and none other and is available directly from Aeromotive and not through any point of distribution or purchase.

If a defect is suspected, the retail purchaser must contact Aeromotive directly to discuss the problem, possible solutions and obtain a Return Goods Authorization (RGA), if deemed necessary by the company. Please call 913-647-7300 and dial option 3 for the technical service dept. All returns must be shipped freight pre-paid to the company and with valid RGA before they will be processed.

Aeromotive will examine any product returned with the proper authorization to determine if the failure resulted from a defect or from abuse, improper installation, misapplication or alteration. Aeromotive will then, at it's sole discretion, return, repair or replace the product.

If any Aeromotive product is determined defective, buyer's exclusive remedy is limited in value to the sale price of the good. In no event shall Aeromotive be liable for incidental or consequential damages.

Aeromotive expressly retains the right to make changes and improvements in any product it manufactures and sells at any time. These changes and improvements may be made without notice at any time and without any obligation to change the catalogs or printed materials.

Aeromotive expressly retains the right to discontinue at any time and without notice any Aeromotive product that it manufactures or sells.

This warranty is limited and expressly limits any implied warranty to one year from the date of the original retail purchase on all Aeromotive products.

No person, party or corporate entity other than Aeromotive shall have the right to: determine whether or not this Limited Warranty is applicable to any Aeromotive product, authorize any action whatsoever under the terms and conditions of this Limited Warranty, assume any obligation or liability of any nature whatsoever on behalf of Aeromotive under the terms and conditions of this Limited Warranty.

This Limited Warranty covers only the product itself and not the cost of installation or removal.

This Limited Warranty is in lieu of and expressly excludes any and all other warranties, expressed or implied. This Limited Warranty gives you specific legal rights, and you may also have other rights which vary from state to state.