

A = Tank Depth , B = Float Pivot Depth , C = Float Arm Length (Dimensions in Inches)								
A	B	C	A	B	C	A	B	C
6.0	3.0	3.5	12.0	6.0	7.8	18.0	9.0	12.0
6.5	3.25	3.8	12.5	6.25	8.1	18.5	9.25	12.3
7.0	3.5	4.2	13.0	6.5	8.5	19.0	9.5	12.6
7.5	3.75	4.5	13.5	6.75	8.9	19.5	9.75	12.9
8.0	4.0	4.9	14.0	7.0	9.3	20.0	10.0	13.4
8.5	4.25	5.3	14.5	7.25	9.6	20.5	10.25	13.8
9.0	4.5	5.6	15.0	7.5	10.0	21.0	10.5	14.2
9.5	4.75	6.0	15.5	7.75	10.4			
10.0	5.0	6.4	16.0	8.0	10.7			
10.5	5.25	6.7	16.5	8.25	11.0			
11.0	5.5	7.1	17.0	8.5	11.4			
11.5	5.75	7.4	17.5	8.75	11.8			

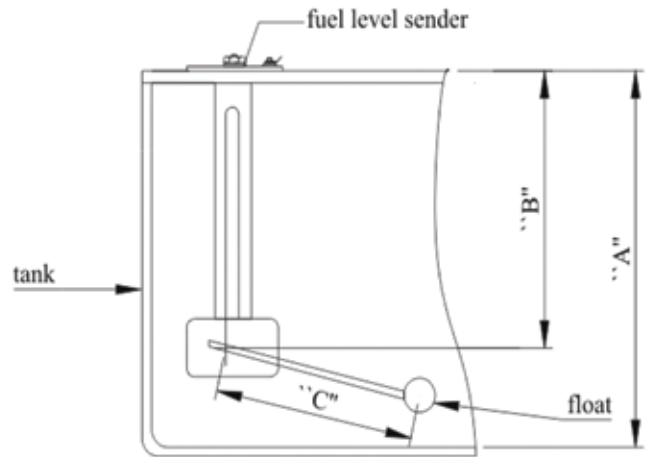

TABLE 1

I. Measure depth of the fuel tank. Locate this dimension in Column "A" of Table 1. Column "B" shows the length from the underside of the sender flange to the center of the float pivot. Column "C" shows distance from the center of the float pivot to the center of the float. For example, a tank 12" deep would need a measurement of 6" from the flange to the pivot and 7.8" from the pivot to the float.

II. For tank depths 6" to 15-1/2", it will be necessary to eliminate a part of the assembly. (See Fig.1) proceed as follows:

1. Remove two screws "d" and discard.
2. Remove two screws "e" from the plastic housing and reserve for later use.
3. Carefully remove bracket "f" from the plastic housing and discard. Replace with bracket "g" in the housing and loosely re-install the two screws "e" into housing.
4. Slide housing up or down until the proper dimension from Table 1 is reached, then tighten screws securely.

CAUTION: Do not over tighten hardware to avoid damage to the threads.

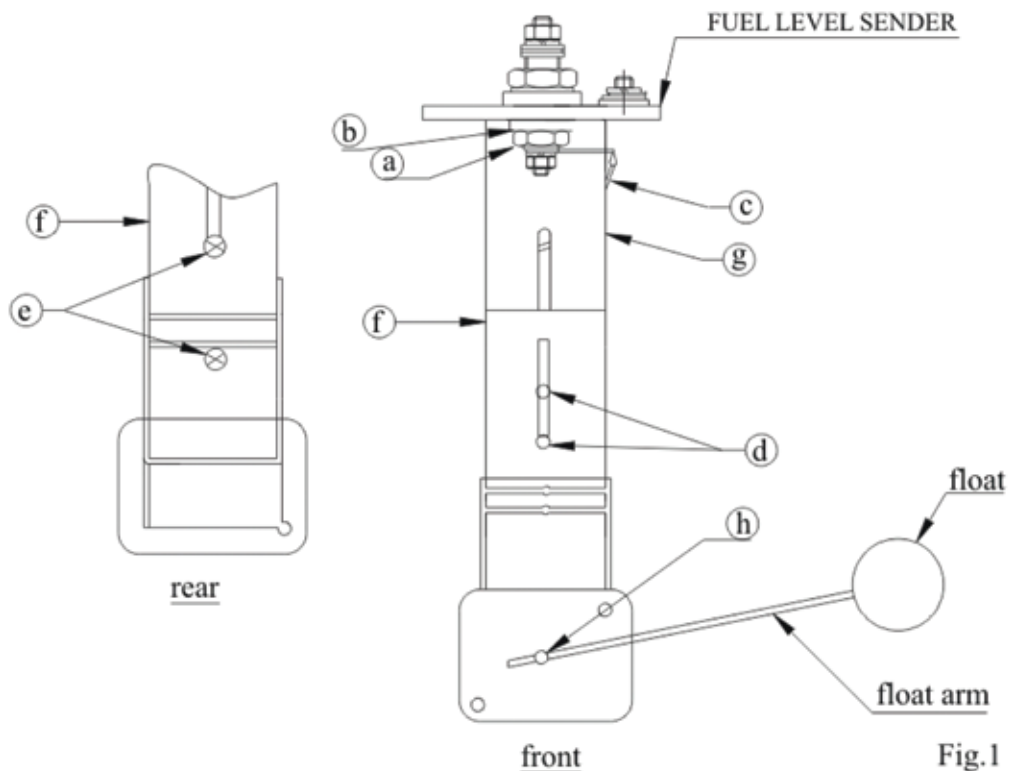

III. For tank depths of 16" to 21" no disassembly of the sender bracket is necessary.

1. Loosen two screws "d" and adjust the plastic housing up or down until the proper dimension from Table 1 is obtained, then retighten screws securely.

IV. To install the float assembly, loosen screw "h", remove the short piece of rod, and discard. Insert the float rod until the proper length "c" from Table 1 is met, and then tighten the screw securely. Carefully cut off any excess rod with bolt cutter or similar tool, taking care not to damage the assembly.

NOTE: Make sure the float is installed as shown in Fig.1. If installed backwards, the fuel gauge will indicate "full" when the tank is empty, and "empty" when the tank is full.

1. Cut the sender bracket so it doesn't extend lower than the black rheostat assembly. The rheostat should be the lowest point of the fuel sender.
2. With the gasket in place below the flange, carefully feed the float arm and sender body into the 1.697" (43mm) hole in the tank. Make certain the float arm has free motion within the tank. Using the sender flange as a template, locate the position of the five mounting holes. Use the supplied screws to mount into the tank with threaded inserts in place.
3. Insert fuel sender assembly into tank, align holes and thread in mounting screws. Check that all screws are secure to complete assembly.
4. Connect the center terminal of the sender to your fuel gauge's signal terminal. Connect the off-center terminal to a good chassis ground.

AVOID OVERTIGHTENING.

