

# QUICK START GUIDE

## DAKOTA DIGITAL HDX INSTRUMENT SYSTEM

This guide is designed to get you up and running quickly with a minimal amount of options installed. It shows a typical and abbreviated wiring diagram as well as how to set up your speedometer, tachometer, and fuel sensor. A detailed description of all the wiring and connections can be found in the full instruction manual.

### \*\*\*\*\* IMPORTANT NOTE! \*\*\*\*\*

This control box has an odometer preset option that is only available within the first 100 miles of driving. See "ODOMETER PRESET MENU" in main instruction manual for details.

- Install the supplied senders. (see sensor pack manual)
- Mount and wire the control box. (see diagram on this sheet or see manual for more detailed descriptions)
- Mount the instrument cluster into your dash. (see mounting instructions or manual)
- Setup the control box by selecting fuel sensor and programming speedometer.

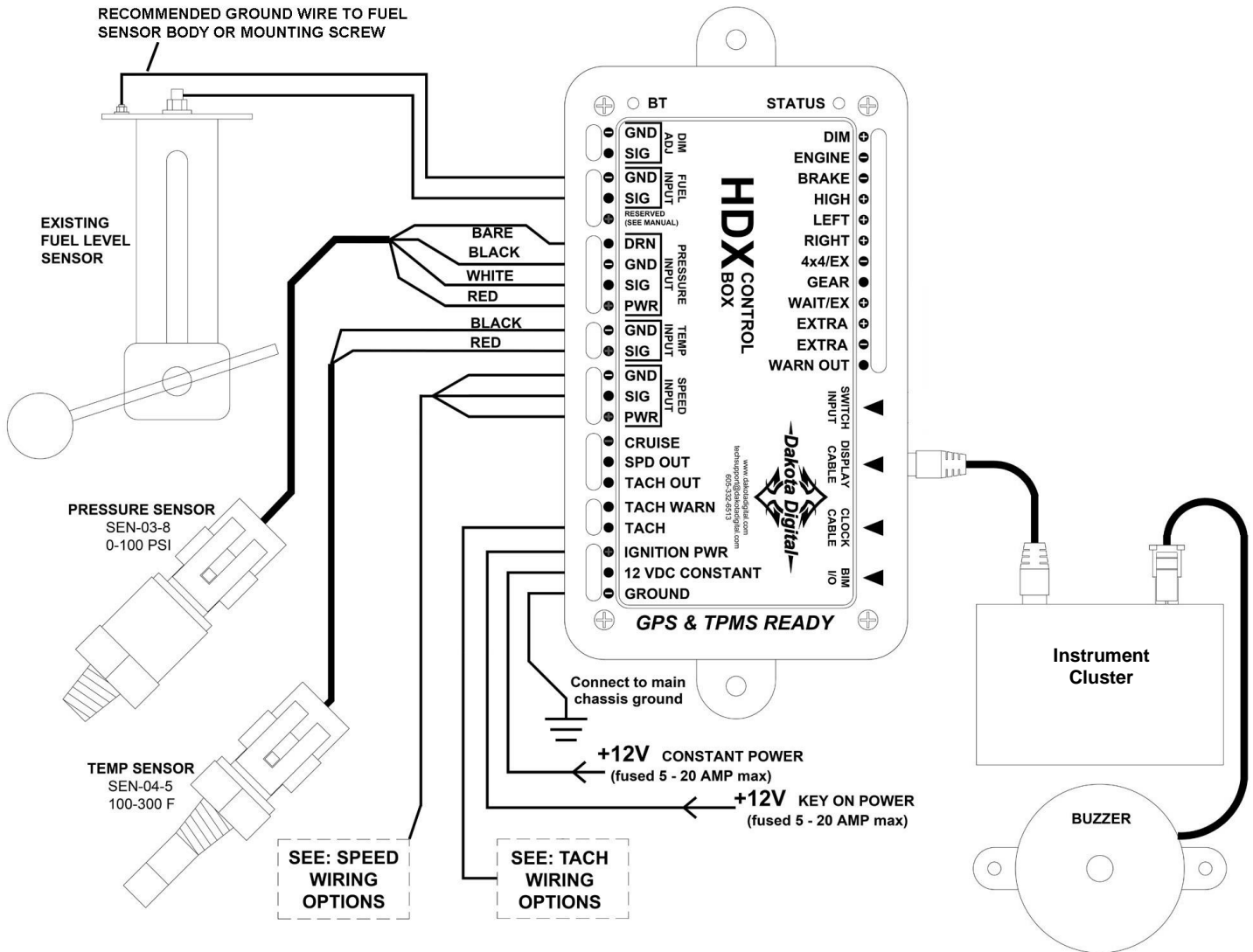

### • Sender Installation

- Oil
  - Chevy small block engines will require a short pipe to clear the manifold. A brass 1/8" NPT pipe nipple with a 45 or 90-degree elbow from a hardware store will work.
  - LS engines have a location above the oil filter that may have a 1/8" NPT port, or one can be tapped.
- Water
  - We recommend mounting our temp sender in the water flow exiting the engine near the thermostat.
  - Cylinder head mounting locations tend to read higher.
  - LS engines provide a 12mm x 1.5 port in the passenger side cylinder head.
    - The supplied metric adapter and crush washer must be used.

**SPEED SENSOR WIRING OPTIONS**

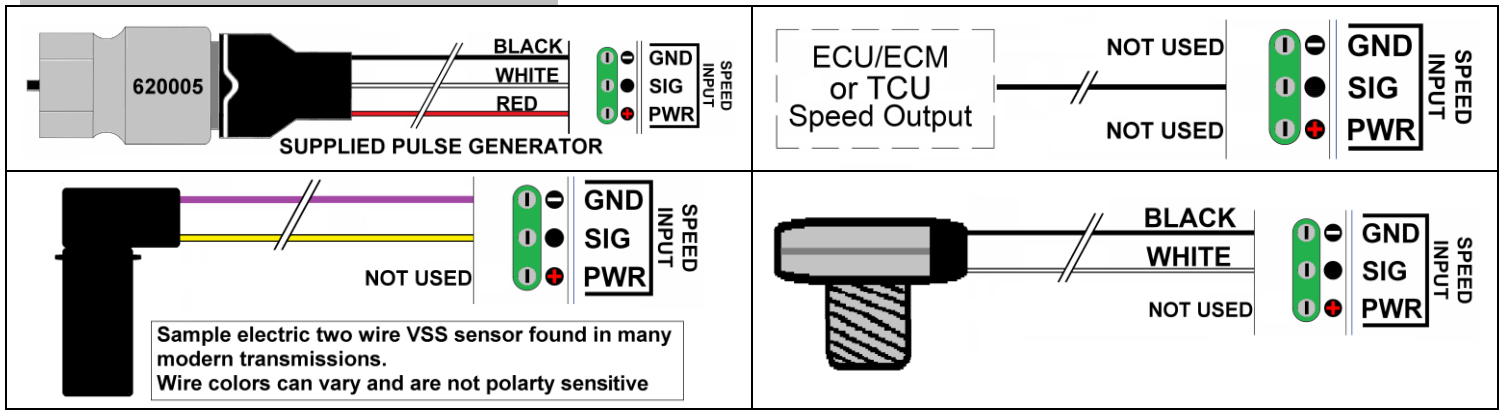

**TACH WIRING OPTIONS**

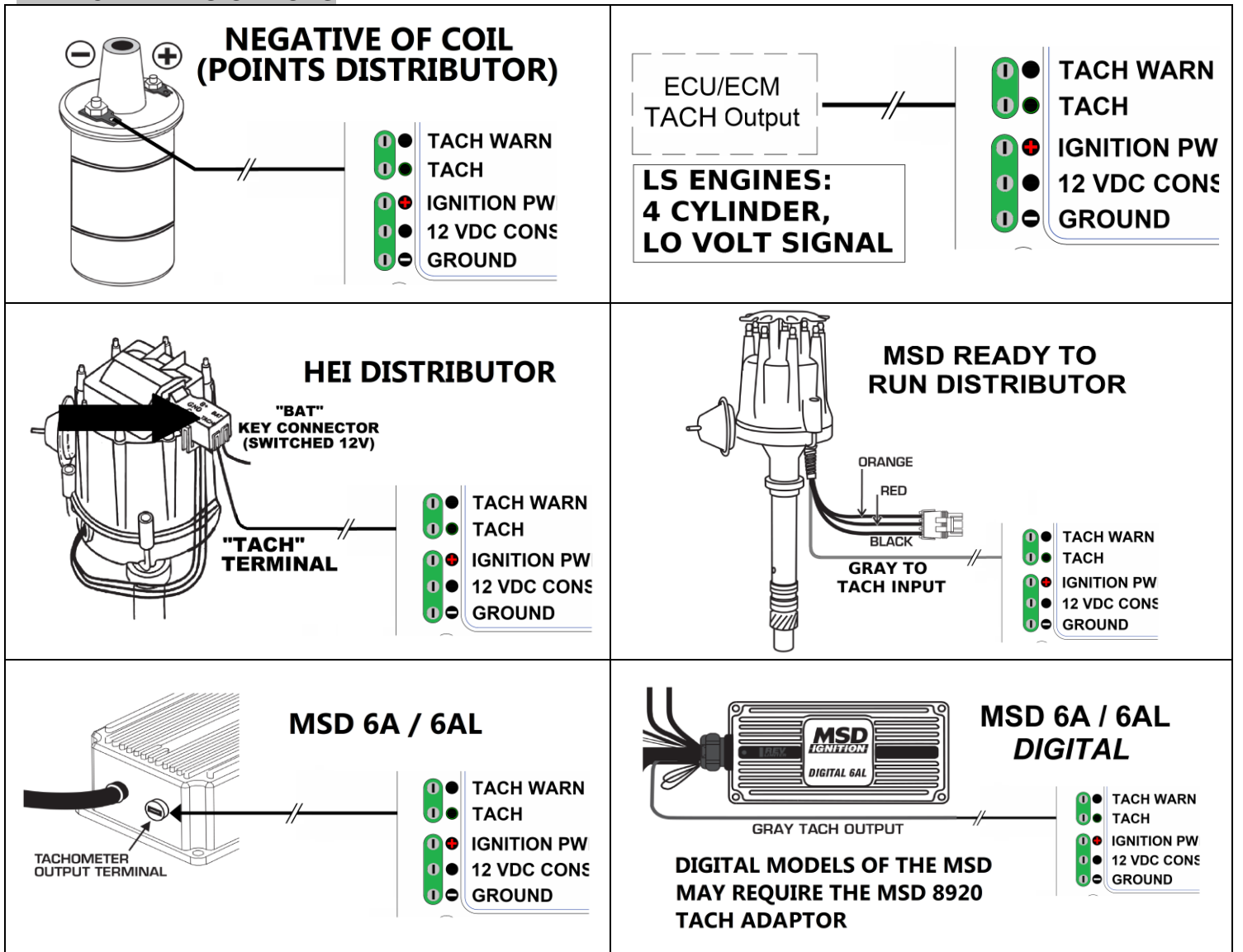

• Diesel engines will require the SGI-100BT to obtain a valid tachometer signal

**Dakota Digital Automotive Bluetooth App**

- The free app for Apple and Android devices can be used to setup all the features
- The HDX system MUST be in Setup mode before changing settings
  - Only Androids must pair to HDX before opening the app

## • Control Box Mounting

- The control box must be mounted inside the cabin of the vehicle
- Do not mount a coil or MSD ignition box inside the vehicle with the control box
  - The high voltage output of either device will interfere with electronics
- Do not mount the control box direct across from distributor on inside firewall
  - A high voltage points or HEI distributor can interfere with electronics
- Do not mount the box near the A/C ducts, to prevent condensation from harming the electronics
- Do not run straight wire leads / harnesses to the control box
  - A loop or bend in the wiring can help prevent any moisture damage
    - A leaky window or condensation can let moisture run into the box without a drip loop

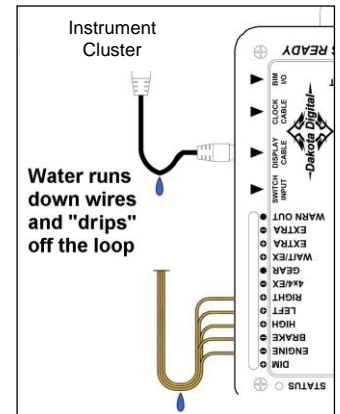

## • Set up the control box to match your vehicle

- Calibrate speedometer, for accurate speed regardless of gearing and tire size
- Adjust the tachometer to match the engine's number of cylinders.
- The fuel gauge must be set to match the sender in your tank. We provide 10 common sender options; if yours is not listed, the system can be programmed to a custom sender
- **A battery disconnect will not cause loss of settings, only the time for the clock.**

## • Switch Operation

- The function switches are on the face on the display, usually below the speedometer
- They do not depress – they are touch sensitive like a smart phone
- The left switch will move a small arrow between different items on the screen(s)
- The right switch will change the group screens displaying different information
- Either switch can clear a red warning message by holding one down for a few seconds



## • Speedometer Calibration

- The setup procedure described below is AUTO CAL using any of the pictured VSS wiring options
- You must have a known one mile (*or one kilometer*) run mapped out prior to starting
  - Drive the car to the beginning of the known mile, **leave engine running**
  - Enter setup by hold holding both switches –> Release when prompted
  - Tap right switch to highlight **SPEED**
  - Hold switch to enter speed setup –> Release when prompted
  - Hold switch as **AUTO CAL** is highlighted –> Release when prompted
  - Display will show **DRIVE 1 MI (KM)** with a 0 below
  - Start driving the distance, the 0 will begin to count up the speed pulses
  - When you reach the end of the mile (*kilometer*) run –> Tap or hold either switch to save
  - The menu will display **BACK** and in an upper screen it will show the number of pulses
  - Hold either switch to exit the speed menu –> Release when prompted
  - Tap until you have **EXIT SETUP** highlighted
  - Hold either switch to exit –> Release when prompted

## • Tachometer Calibration

- Old school V-8 points or HEI systems: with or without a MSD box, will not need any setup
- Six and four cylinder engines need the cylinder count changed
- LS engines: signal from the ECM will read as a four cylinder, and it will be a low voltage input
  - Enter setup by hold holding both switches –> Release when prompted
  - Tap left switch to highlight **TACH** –> Hold switch to enter tach setup –> Release when prompted
  - The display will show **INPUT** –> Hold switch to enter **Input** setup –> Release when prompted
  - The display will show **CYLINDER** –> Hold switch for **Cylinder** setup –> Release when prompted
  - The display will show the cylinder count with **\*3** as the current default setting
  - Tap the left button until **4** is displayed –> Hold switch to save –> Release when prompted

• **Tachometer Calibration (continued)**

- The display will show **CYLINDER**
- Tap the right switch to change display to **TYPE**
- Hold switch to enter **Type** setup –> release when instructed on screen
- The display will show **\*12V HIGH** as the default tach voltage
- Tap the right switch to highlight **5V LOW**
- Hold switch to save –> Release when instructed on screen
- You may stop by turning the key off or go **“Back”** in each menu and **“Exit Setup”**

• **Fuel Setup**

- Enter setup by hold holding both switches, release when instructed on screen
- Tap left switch to highlight **FUEL** –> Hold switch to enter fuel setup –> Release when prompted
- The display will show **INPUT**
- Hold switch to enter fuel sender choices –> Release when prompted
- Use the switches to scroll up or down to highlight your sender from the list below
  - As each sender is highlighted, the fuel needle will respond to that choice

Fuel Sender type	Menu	Empty R	Full R
Chrysler – typically uses a 73-10 ohm	<b>FORD 73-10</b>	73 ohms	10 ohms
GM 0-30 ohm (mid 60’s-earlier)	<b>GM 0-30</b>	0 ohms	30 ohms
GM 0-90 ohm (mid 60’s-late 90’s)	<b>GM 0-90</b>	0 ohms	90 ohms
GM 40-250 ohm (late 90’s-later)	<b>GM 40-250</b>	40 ohms	249 ohms
GM 250-40 ohm	<b>GM 250-40</b>	249 ohms	40 ohms
GM 90-0 ohm (63-67 Corvette)	<b>63 VETTE</b>	90 ohms	0 ohms
FORD 73-10 ohm (earlier -late 80’s)	<b>FORD 73-10</b>	73 ohms	10 ohms
FORD 20-150 ohm (late 80’s-later)	<b>FORD 20-150</b>	20 ohms	150 ohms
VDO 10-180 ohm	<b>VDO 10-180</b>	10 ohms	180 ohms
SW/SUN 33-240	<b>SW 240-33</b>	240 ohms	33 ohms
ASIA 112-4 ohm (various imports)	<b>ASIA 112-4</b>	112 ohms	4 ohms
User programmed	<b>MANUAL ADJ</b>	User settable	User settable

- Hold switch to save, release when instructed on screen
- Tap switch to highlight **BACK** –> Hold switch to save –> Release when prompted
- Tap switch to **EXIT MENU** –> Hold switch to save –> Release when prompted

**See full installation manual for custom fuel sender calibration in the MANUAL ADJ mode**

• **Clock Setup(not visible with all LCD layouts)**

- Small screens will not display a clock in the main speed screen
- The clock must be added to a Group Screen
  - Small screens will only have two locations to display, Screen 1 and Screen 2
- Tapping the right will change Group screens
- When the main LCD is showing speed, tap the left switch to move a small arrow next to the clock
- Hold the left switch –> Release when prompted –> The hours will begin flashing
- Tapping the left button will decrease hours, while the right will increase hours
- When the correct hour is displayed –> Hold the switch to save –> Release when prompted
- The minutes will be flashing –> Tap left to decrease minutes –> Tap right to increase minutes
- Hold the switch to save –> Release when prompted

**⚠WARNING:** This product can expose you to chemicals including lead, which is known to the State of California to cause cancer and birth defects or other reproductive harm. For more information go to [www.P65Warnings.ca.gov](http://www.P65Warnings.ca.gov)



4510 W. 61st St. North  
 Sioux Falls, SD 57107  
 www.dakotadigital.com  
 dakotasupport@dakotadigital.com

Phone (605) 332-6513  
 Fax (605) 339-4106

© Copyright 2023 - Dakota Digital