

WARNING!

Always wear gloves and protective eye-wear when operating a drill of any kind. If any part of this installation seems beyond your level of installation experience, please seek the help of a professional.

TOOLS REQUIRED FOR INSTALLATION

- Drill (90° gun is preferred)
- Drill bits 1/16", 1/8", 7/32"
- Center punch
- Deburring tool
- 2mm, 3mm allen wrench
- 5.5mm, 8mm hex wrench
- 10mm socket
- Socket wrench
- Masking tape
- Sharpie
- Safety glasses
- Catch mat

KIT INCLUDES:

Qty	Description
1	Aluminum Gas Pedal Cover
1	Aluminum Brake Pedal Cover (Automatic)
2	Aluminum Brake / Clutch Pedal Cover (Manual)
4	M3 16mm Allen bolt with nylock nuts
4	M5 16mm Allen bolt with washer and nylock nut (Automatic)
6	M5 16mm Allen bolt with washer and nylock nut (Manual)
1	Rubber Gas Pedal Cover
5	Gas Pedal Brackets (see Gas Pedal Hardware on last page)

INSTALLATION (SEE LAST PAGE FOR EXPLODED VIEWS)

For Brake & Clutch Pedals

1. Lay down a blanket or "catch mat" underneath your work area to collect debris from drilling
2. Remove the factory pedal covers on brake & clutch (if applicable)
3. Cover the brake & clutch pedals with masking tape (Pic 1)
4. Place the new billet pedal cover on top of the pedal, and use a sharpie to mark the center of the mounting holes (Pic 2)
5. Remove billet cover and center punch the center of marked dots (Pic 3)
6. Drill holes at marked locations stepping up from 1/16" to 1/8" to 7/32" drill bits. Make sure to drill perpendicular to surface. It is recommended that you use a 90 degree drill gun for this.
7. Remove masking tape and debur the holes (Pic 4)
8. Using a 3mm allen wrench and 8mm hex wrench install the billet covers with provided countersunk bolts, washers, and nylock nuts

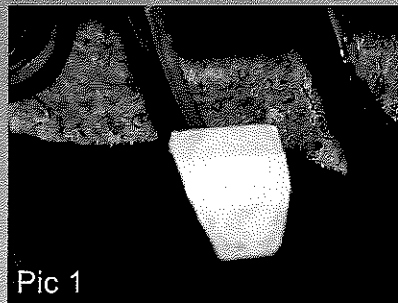

Pic 1

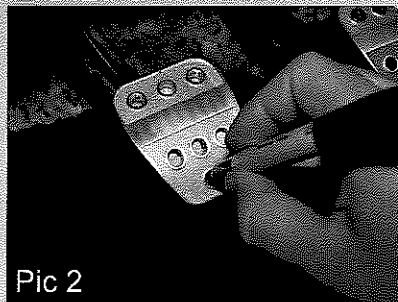

Pic 2

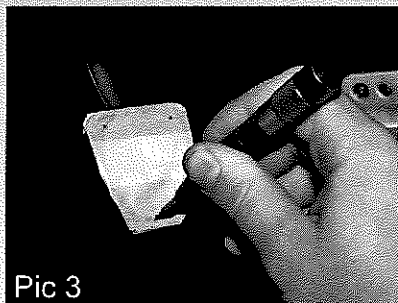

Pic 3

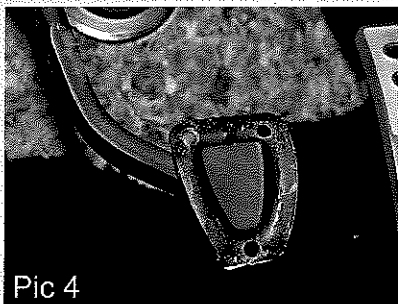

Pic 4

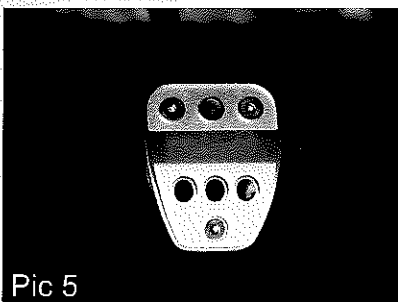

Pic 5

(Pic 5)

For Gas Pedal

1. For installation of the gas pedal cover, we found it is easier to remove the pedal assembly from the car. Using a 10mm socket, remove the 3 nuts that attach the gas pedal assembly under the dash and set the nuts aside. You will need to reuse them to reinstall the pedal assembly. Then unplug the electrical harness connected to the gas pedal assembly. (Pic 6)
2. Install the supplied rubber gas pedal pad (A) into the back of the new Drake pedal cover
3. Using a 2mm Allen wrench and 5.5mm wrench loosely attach lower bracket (D) for 2005-2010 or (F) for 2011-2015 to the gas pedal cover. Do not tighten yet. See Fig 1 and Fig 2 for reference.
4. Slip the new gas pedal cover onto the gas pedal then attached bracket B. Use a 2mm Allen wrench and 5.5mm wrench.
5. Using a 2mm Allen wrench and 5.5mm wrench install bracket (C) for 2005-2010 or (E) for 2011-2015 on to the back of the pedal cover. See Fig 1 and Fig 2 for reference.
6. Tighten all hardware and make sure the pedal cover is securely installed and aligned properly.
7. Using a 10mm socket, reinstall the gas pedal assembly into the car with the (3) nuts removed in step 1. Torque them to 7 ft-lbs.
8. Reconnect the electrical harness attached to the pedal assembly.

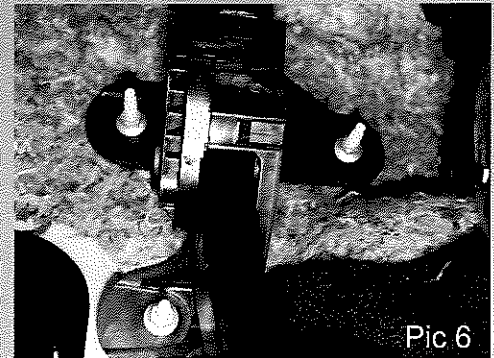

Pic 6

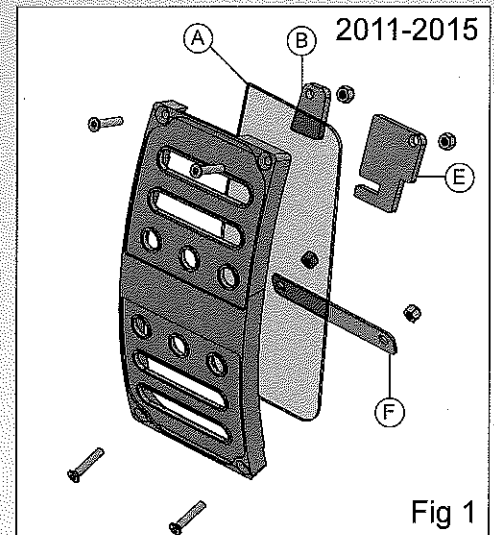

Fig 1

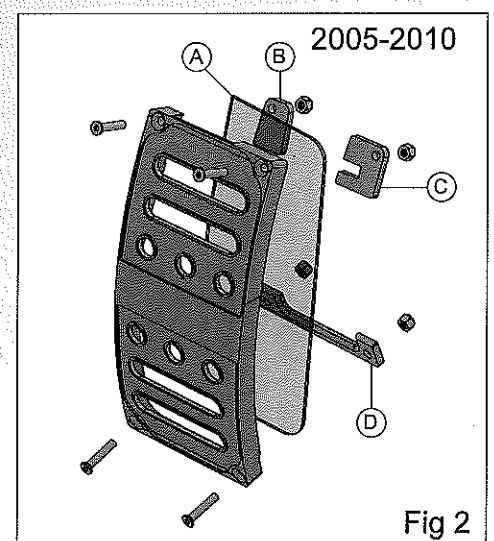
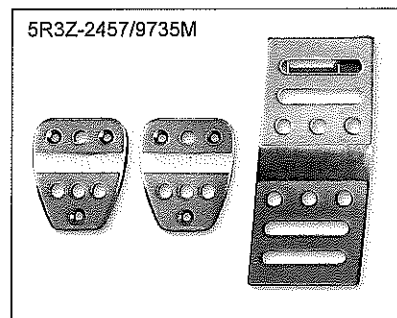
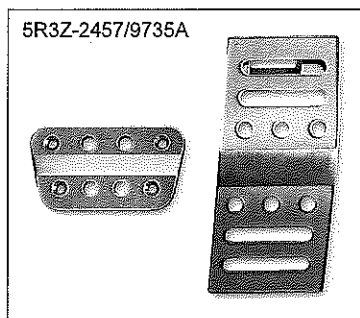
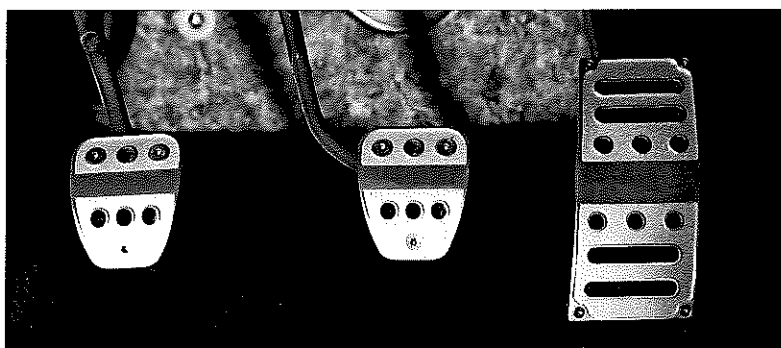

Fig 2



Drake Muscle Cars

130 Cassia Way, Henderson, NV 89014
Tel: (702) 853-2060 www.DrakeMuscleCars.com

