



Technical Support Line: (952) 985-5675 Email: Info@QA1.net

21730 Hanover Ave.  
Lakeville, MN 55044  
www.QA1.net

### INSTALLATION INSTRUCTIONS

*QA1 P/N RCK52610-RCK52617 Rear Coil-Over Conversion with Panhard Bar  
'63-'72 Chevrolet C10, GMC C15/C1500 Pickup with Rear Coil Spring Suspension*

READ ALL INSTRUCTIONS CAREFULLY AND THOROUGHLY PRIOR TO STARTING INSTALLATION. PRODUCTS THAT HAVE BEEN INSTALLED ARE NOT ELIGIBLE FOR RETURN. USE THE PROPER JACKING LOCATIONS. DEATH OR SERIOUS INJURY CAN RESULT IF INSTRUCTIONS ARE NOT CORRECTLY FOLLOWED. A GOOD CHASSIS MANUAL, AVAILABLE AT YOUR LOCAL PARTS STORE, MAY ALSO AID IN YOUR INSTALLATION.

#### • DISCLAIMER / WARRANTY •

QA1 WARRANTS THAT THE PRODUCTS WILL BE FREE FROM DEFECTS IN MATERIAL AND WORKMANSHIP FOR ONE YEAR FROM DATE OF SALE TO THE ORIGINAL PURCHASER. QA1 MAKES NO OTHER WARRANTY OF ANY KIND, EXPRESS OR IMPLIED. QA1 SHALL HAVE NO OBLIGATION UNDER THE FOREGOING WARRANTY WHERE THE DEFECT IS THE RESULT OF IMPROPER OR ABNORMAL USE, YOUR NEGLIGENCE, VEHICLE ACCIDENT, IMPROPER OR INCORRECT INSTALLATION OR MAINTENANCE, NOR WHEN THE PRODUCT HAS BEEN REPAIRED OR ALTERED IN ANY WAY. QA1'S LIABILITY IN THE CASE OF DEFECTIVE PRODUCTS SUBJECT TO THE FOREGOING WARRANTY SHALL BE LIMITED TO THE REPAIR OR REPLACEMENT, AT QA1'S OPTION, OF THE DEFECTIVE PRODUCTS.

THE USER UNDERSTANDS AND RECOGNIZES THAT RACING PARTS, SPECIALIZED STREET ROD EQUIPMENT, AND ALL PARTS AND SERVICES SOLD BY QA1 ARE EXPOSED TO MANY AND VARIED CONDITIONS DUE TO THE MANNER IN WHICH THEY ARE INSTALLED AND USED. QA1 SHALL BEAR NO LIABILITY FOR ANY LOSS, DAMAGE OR INJURY, EITHER TO A PERSON OR TO PROPERTY, RESULTING FROM THE INSTALLATION, DIRECT OR INDIRECT USE OF ANY QA1 PRODUCTS OR INABILITY BY THE BUYER TO DETERMINE PROPER USE OR APPLICATION OF QA1 PRODUCTS. WITH THE EXCEPTION OF THE LIMITED LIABILITY WARRANTY SET FORTH ABOVE, QA1 SHALL NOT BE LIABLE FOR ANY CLAIMS, DEMANDS, INJURIES, DAMAGES, ACTIONS, OR CAUSES OF ACTION WHATSOEVER TO BUYER ARISING OUT OF OR CONNECTED WITH THE USE OF ANY QA1 PRODUCTS. MOTORSPORTS ARE DANGEROUS; AS SUCH, NO WARRANTY OR REPRESENTATION IS MADE AS TO THE PRODUCT'S ABILITY TO PROTECT THE USER FROM INJURY OR DEATH. THE USER ASSUMES THAT RISK!

### TOOLS AND SUPPLIES REQUIRED

- Floor Jack
- Four (4) Jack Stands
- Drill with 3/8" drill bit
- SAE Wrench Set
- Ratchet & SAE Socket Set
- Torque Wrench
- Grinder or Air Chisel
- Anti-seize
- T114W or T115W Spanner Wrench

### Pre-Installation Note

A grinder or air chisel is recommended for removal of factory rivets.

### Disassembly Instructions

1. Raise the vehicle and support the frame with jack stands on a stable surface.
2. With a jack supporting the axle, remove the wheels, shocks and factory springs.
3. Set the axle on jack stands.
4. Disconnect and remove the factory panhard bar from the frame mount and axle.
5. The factory panhard bar mount on the left side frame rail and the gusset plate direct above the mount can now be removed. Remove the rivets with a grinder and punch or an air chisel. See **Figure 1**.

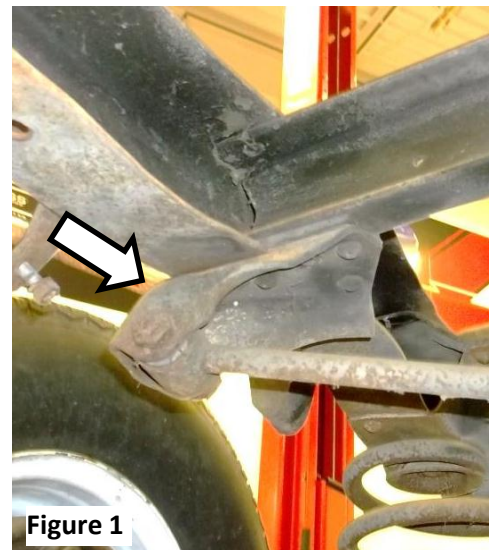

6. Remove the bottom rivets from the panhard bar cross member on the right side frame rail.

## Installation Instructions

1. Assemble the Panhard bar per **Figure 7** on page 4. Apply anti-seize to the threads and thread the rod end and adjuster all the way in to ensure even thread engagement.
2. Assemble the JNL12S jam nut on XML10-12 rod end and JNR12S jam nut on XMR10-12 rod end. Apply anti-seize and fully thread both rod ends into the panhard bar support brace, P/N 9037-566 per **Figure 7** on page 4.
3. Install the left side shock mount using the existing holes from the cross member rivets with 3/8" x 1 1/4" bolts with washers. Tighten the bolts and use the bracket as a template for the remaining holes. Mark and drill the remaining three holes to 3/8". Install the remaining three 3/8" x 1 1/4" bolts using flat washers under the head of the bolts and on the nuts. Torque to 30 lb. ft. See **Figure 2**.
4. Install the right side frame shock mount bracket with 3/8" x 1 1/4" bolts with washers using the existing holes from the cross member rivets. Tighten the bolts and mark and drill the remaining holes using the bracket as a template. Install the remaining three 3/8" x 1 1/4" bolts using flat washers under the head of the bolts and on the nuts. Torque to 30 lb. ft.
5. Loosen and remove the axle to truck arm U-bolts one at a time to install the lower shock mount bracket. **Caution: Truck arms are heavy steel parts that can cause injury if unsupported during removal or installation.**
6. Install the truck arm saddle brackets between the axle and the truck arm and reinstall the truck arm on the axle. **Note: New U-bolts are recommended.** The truck arms may need minor trimming to allow the brackets to sit flat on the truck arms. Repeat on the other side of the vehicle. See **Figure 3**. Torque the U-bolt nuts to 145 lb. ft.
7. Install the shock mount brackets on the insides of the truck arm saddle brackets with the 3/8" x 1" bolts with a washer under the head of the bolts and the nuts as shown in **Figure 3**. The shock mount position can be adjusted up to raise the vehicle or lowered to lower the vehicle ride height, but there should be one at least open hole between the mounting bolts. Torque the bolts to 30 lb. ft.
8. Install the assembled shock and spring into the shock mounts with the supplied 1/2" x 2 1/2" bolts nuts and washers. Spacer P/N 9033-430 will be used on each side of the bearing for the lower shock mounts. Torque to 50 lb. ft.
9. Install the panhard bar and panhard bar support rod on the left side frame bracket with the support rod towards the rear of the vehicle using the holes in the center of the adjustment range. The 5/8" x 4 1/4" bolt will be used with a SG104 spacer on each side of the rod end and a flat washer between the spacer and the panhard bar bushing. See **Figure 4**.
10. Install the panhard bar support rod on the right side frame bracket with a SG104 spacer on each side of the rod end and the 5/8" x 2 1/2" bolt, nut and washers. Adjust the length of the support rod until the bolt holes line up by holding the rod end and turning the tube to ensure equal thread engagement on each rod end when adjusting the length.



Figure 2

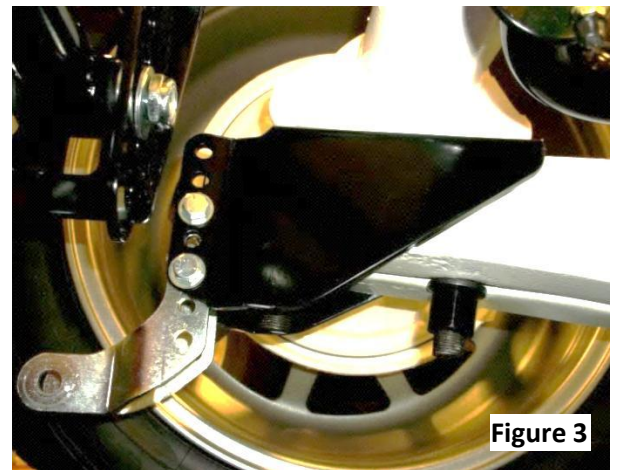

Figure 3

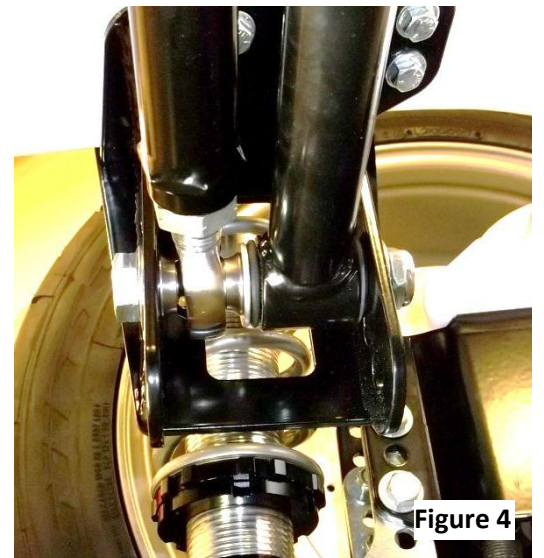

Figure 4



11. Install the panhard bar on the truck arm saddle bracket using the 5/8" x 3" bolt, washers and nut. A SG108 spacer will be used on each side of the rod end. Adjust the length of the panhard bar until the bolt holes line up by holding the rod end and turning adjuster to ensure equal thread engagement on the rod end and adjuster when adjusting the length. See **Figure 5**. **Note:** The panhard bar height will need to be adjusted once the truck is set at ride height.

12. Reinstall the driveshaft if removed.

13. Reinstall the wheels and tires.

14. With the shocks installed, adjust the shock length with the threaded adjustment until the shock measures 14-15" when the suspension is loaded. Then use the adjustable mounts to set the truck at the desired ride height.

**Note:** The suspension should be unloaded when making any ride height changes to prevent damage to the shocks.

15. Adjust the panhard bar height so the panhard bar is level when the truck is at ride height. See **Figure 6**.

16. Once the panhard bar is level, use the adjuster on the panhard bar to center the axle under the truck by measuring from the wheel rim to the frame on each side of the vehicle. Once the panhard bar length is set, tighten all bolts and jam nuts.

17. Check and adjust the pinion angle as needed. Installation of the relocation brackets and/or changing the ride height of the vehicle will change the pinion angle and may require shims between the truck arms and axle to correct this.

18. Check **all** mounting hardware for tightness.



**Figure 5**



**Figure 6**

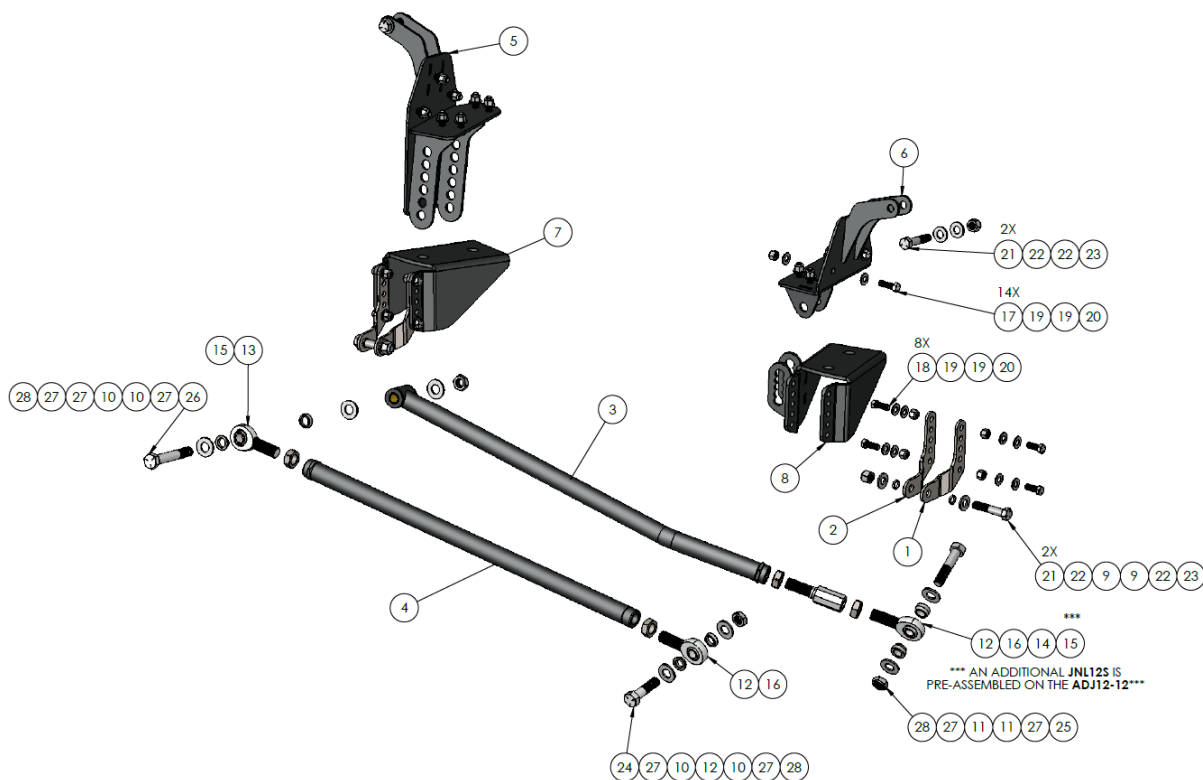

Item #	Item	Description	QTY.	Item #	Item	Description	QTY.
1	9037-104	BRACKET, SHOCK MOUNT, L, BOLT ON	2	15	JNL12S	JAM NUT, STEEL 3/4-16 LH	2
2	9037-105	BRACKET, SHOCK MOUNT, R BOLT ON	2	16	JNR12S	JAM NUT, 3/4-16 RH	2
3	9037-561	ASSEMBLY, PANHARD BAR	1	17	*	3/8"-16 x 1.25 Grade 5 Bolt	14
4	9037-566	WELDMENT, BRACE BAR	1	18	*	3/8"-16 x 1 Grade 5 Clear Zinc Bolt	8
5	9037-579	WELDMENT, SHOCK MT, DRIVER SIDE	1	19	*	WASHER, FLAT 3/8" SAE	44
6	9037-582	WELDMENT SHOCK MT, PASS SIDE	1	20	*	NUT, NYLOCK 3/8-16	22
7	9037-587	PLATE, DRIVER SIDE ADAPTER	1	21	*	1/2"-20 x 2.5 Grade 5 Clear Zinc Bolt	4
8	9037-588	WELDMENT, PASS SIDE ADAPTER	1	22	*	1/2" x 1.062 OD SAE Washer	8
9	9033-430	SLEEVE, .500" ID X .625" OD X .125"	4	23	*	1/2"-20 Grade 5 Nut Nylock	4
10	SG104	SPACER ROD END SS	4	24	*	5/8"-11 x 2.5 Grade 5 Clear Zinc Bolt	1
11	SG108	SPACER ROD END SS	2	25	*	5/8"-11 x 3 Grade 5 Clear Zinc Bolt	1
12	XMR10-12	ROD END (X) ENDURA ALLOY HT	2	26	*	5/8"-11 x 4 Grade 5 Clear Zinc Bolt	1
13	XML10-12	ROD END (X) ENDURA ALLOY HT	1	27	*	5/8" x 0.656 OD SAE Washer	7
14	ADJ12-12	LINKAGE ADJUSTER STEEL CP 3/4-16	1	28	*	5/8"-11 Grade 5 Thin Nylock	3
*** AN ADDITIONAL JNL12S IS PRE-ASSEMBLED ON THE ADJ12-12***							

## Dedicated Technical Support Team

QA1 is dedicated to providing quality support and instructions. We employ passionate racers and car enthusiasts that know our products and the industry to better serve you.

Give our tech support line a call at **1.800.721.7761**

Visit online at [www.QA1.net/tech](http://www.QA1.net/tech) or [www.YouTube.com/QA1Tech](http://www.YouTube.com/QA1Tech) for:

- Frequently Asked Questions
- Quick Tips
- Install Information
- Tuning and Repair Guides
- Other Technical Information

Our technical support and order lines are open **Monday – Friday, 8 am to 5 pm CST.**

