

S5211

2021-UP FORD F150,
5.0L, 3.5L ECOBOOST, 2.7L ECOBOOST
EXCL. POWERBOOST, CAT-BACK, 3.0"
SINGLE SIDE

MBRP®

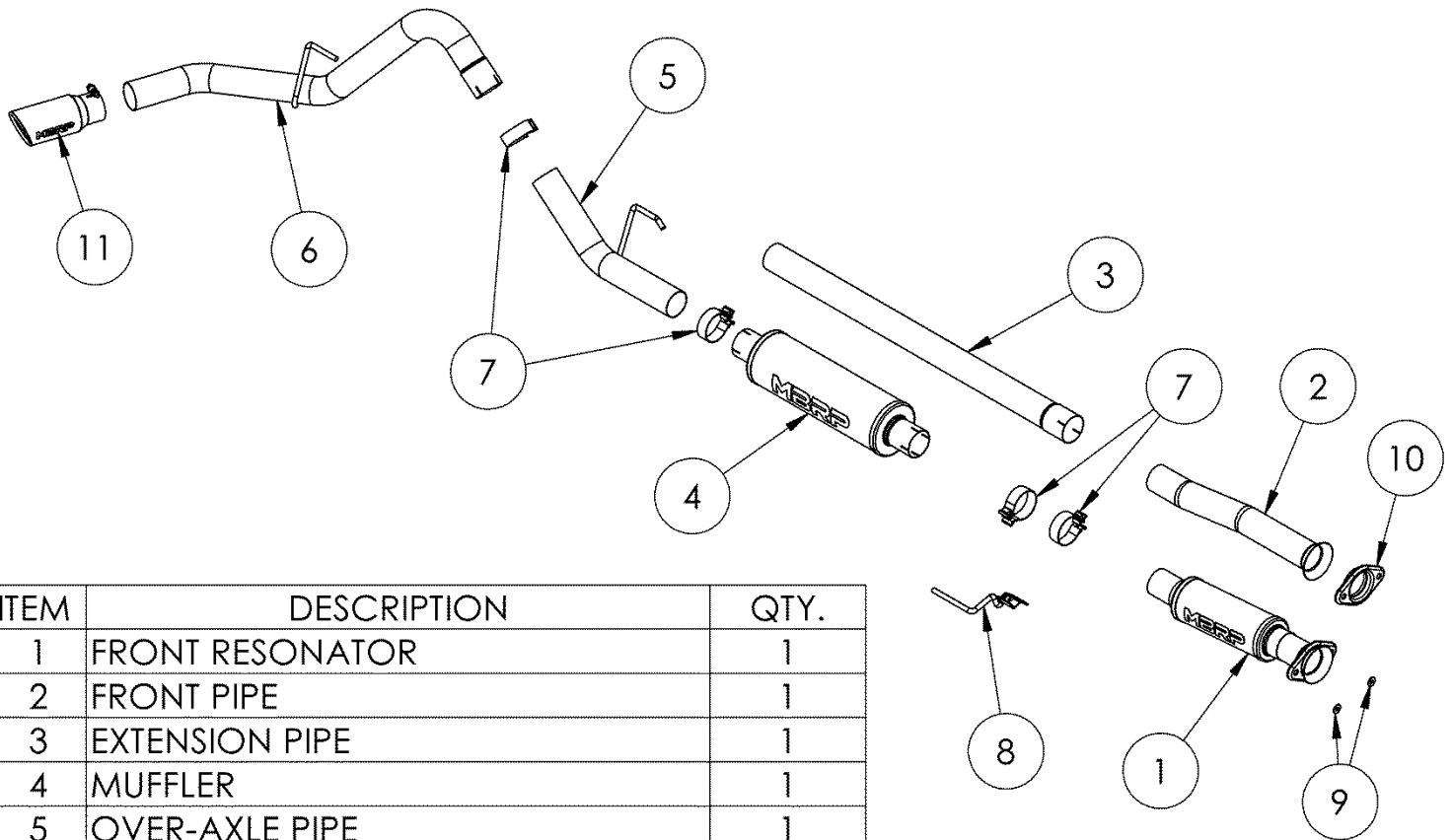

ITEM	DESCRIPTION	QTY.
1	FRONT RESONATOR	1
2	FRONT PIPE	1
3	EXTENSION PIPE	1
4	MUFFLER	1
5	OVER-AXLE PIPE	1
6	TAIL PIPE	1
7	3.0" CLAMP	4
8	HANG TIGHT™ HANGER	1
9	3/8" FLAT WASHER	2
10	FLANGE	1
11	EXHAUST TIP	1

PLEASE READ BEFORE STARTING INSTALLATION

While MBRP has made every effort to ensure that all components of this system are of superior quality and properly packaged, it is the installer's responsibility to ensure the following before removal of the factory exhaust:

- that ALL components shown above are present.
- that ALL mating components fit together.
- that there are no damaged components.
- that the system you have purchased is appropriate for your vehicle year, model and configuration.
- that the system will not interfere with any modifications previously installed or planned.
- that you have read and understand these instructions.

If you have any questions or are uncertain about any aspect of the installation of this system to your vehicle please contact your dealer before commencing installation.

MBRP

Removal of Stock System:



Figure 1

1. Apply a penetrating lubricant liberally to all hangers and rubber isolators.
2. Loosen the factory clamp in front of the muffler.
3. Loosen the factory extension pipe flange bolts.

Refer to Figure 1.

4. Rotate the factory extension pipe to release the factory muffler inlet locking boss.

Refer to Figure 2

5. Remove the factory muffler assembly from the hangers and remove from the vehicle

6. Remove the factory extension pipe bolts and remove the factory extension pipe from the vehicle. Retain the factory bolts for the installation.

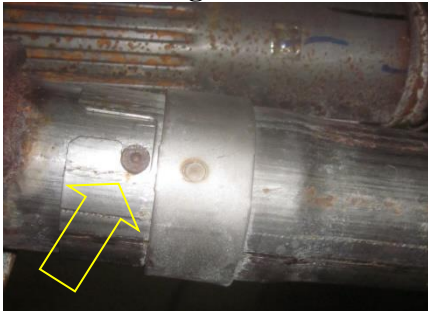

Figure 2

Installation of MBRP Performance Exhaust:

1. Determine the length of the **Extension Pipe** (if required).

Refer to Figure 3.

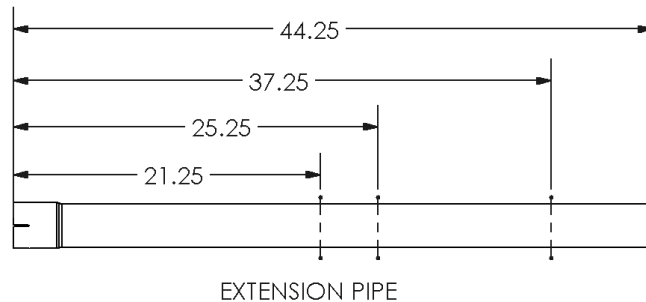

Figure 4

WHEELBASE	EXTENSION PIPE LENGTH
122" RC 6.5' BOX	NONE
141" RC 8' BOX	21.25"
145" EC 6.5' BOX/ SC 5.5' BOX	25.25"
157" SC 6.5' BOX	37.25"
164' EC 8' BOX	44.25" (NO CUT)

Figure 3.



Figure 5

2. Loosely install the **Front Resonator**, or **Front Pipe** and **Flange**, using the factory bolts and the supplied **3/8" Flat Washers**.

It is recommended to use the **Front Resonator** on the 5.0L engine, or for a more aggressive sound, use the **Front Pipe**. The **Front Pipe** is recommended for EcoBoost engines, but the **Front Resonator** can provide a more subtle sound.

Refer to Figure 4.



Figure 6

3. Install the appropriate length **Extension Pipe** (if required) onto the front pipe using a **3" Clamp**.

Refer to Figure 5.

MBRP



Figure 7



Figure 8



Figure 9



Figure 10



4. Install the **Hang Tight™ Hanger** onto a **3.0" Band Clamp** using the procedure shown below. (Hang Tight™ Hanger not exactly as shown)

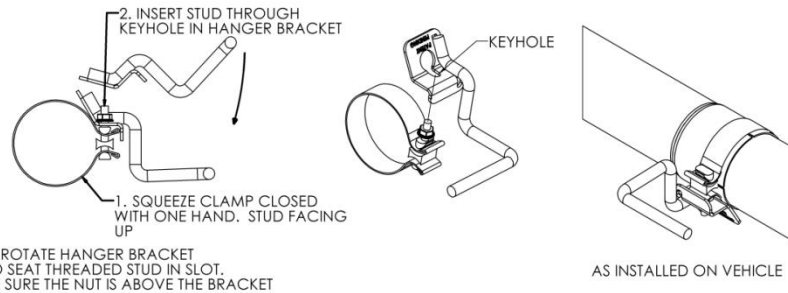

5. Install the **Hang Tight™ Hanger Clamp Assembly** onto the **Extension Pipe** and into the factory isolator. (5.0L shown. On EcoBoost models, use the rear-most factory isolator)

Refer to Figure 6.

6. Install the **Muffler** onto **Extension Pipe** and lightly secure with the **Hang Tight™ Hanger Clamp Assembly**. Do not completely tighten at this time. (EcoBoost shown.)

Refer to Figure 7.

7. Place a **3" Clamp** over the **Muffler** outlet and insert the **Over Axle Pipe** into the factory isolator and **Muffler**.

Refer to Figure 8.

8. Install a **3" Clamp** and the **Tail Pipe** onto the **Over Axle Pipe** and into the factory isolator. Snug, but do not completely tighten the **3" Clamp**.

Refer to Figure 9.

9. Install the **Exhaust Tip** and adjust to your liking.

Refer to Figure 10.

10. Align the edge of each band clamp with the edge of the joint it is connecting. Tighten all hardware and clamps, starting at the front and working rearward to secure the system. Check along the full length of the exhaust system to ensure there is adequate clearance for fuel lines, vent lines, brake lines, frame, bodywork, suspension, and any wiring, etc. If there is any interference detected, relocate, or adjust to provide adequate clearance. Ensure all clamp connections are secure and components are unable to rotate or slide. Band clamps require approximately 45 lb-ft (60 N-m) of torque. Verify clearances, system security and band clamp torque after 30-60 miles (50-100 km) of driving.

Congratulations! You are ready to begin experiencing the improved power, sound and driving experience of your **MBRP** performance exhaust system. We know you will enjoy your purchase.