

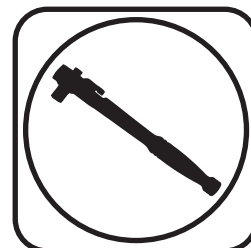

12122650

1979-1993 Mustang SLA Front Suspension Kit for Aftermarket K-Members

Recommended Tools

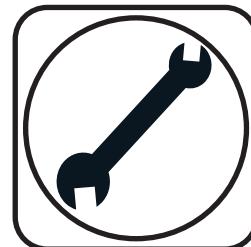
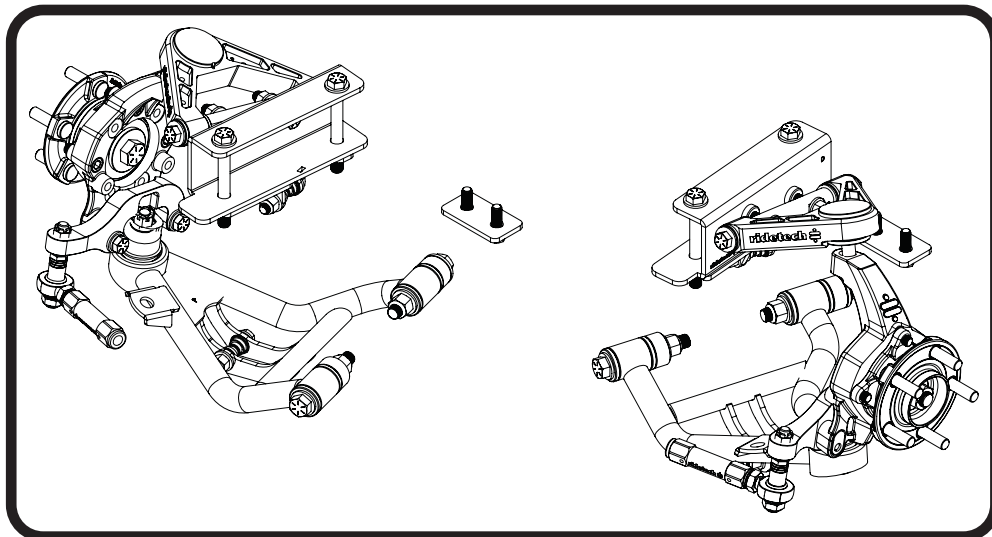

79-93 Mustang Front Suspension Installation Instructions

Table of contents

Page 2-3.....	Component Assemblies
Page 4-6.....	Included Components & Lists
Page 7.....	Hardware List
Page 7.....	Important Notes
Page 7-12.....	Disassembly
Page 13-18.....	Frame Surround Installation
Page 18-20.....	Lower Control Arm Installation
Page 20-22.....	Shock Installation
Page 22-23.....	Upper Control Arm Installation
Page 23.....	Spindle Installation
Page 24-25.....	Hub Bearing & Steering Arm Installation
Page 26.....	Steering Linkage Installation
Page 27-28.....	Outer Tie Rod Installation
Page 28.....	Sway Bar Installation
Page 28.....	Finishing and Alignment



This system includes 2015-2023 S550 Mustang rear hubs. If replacing these in the future, the 3/4" retaining bolt and t-washers must be installed into the new hub. **Failure to do will result in immediate bearing failure.** See page 2.

www.ridetech.com



REV0 6/5/23



This system includes 2015-2023 S550 Mustang rear hubs. If replacing these in the future, the 3/4" retaining bolt and t-washers must be installed into the new hub. This hardware needs to be torqued to 200 ft-lbs. **Failure to do will result in immediate bearing failure.**

Item #	Part Number	Description	QTY
A	70013663	Hub Bearing (Moog 512517)	1
1	90003508	Top T-Washer	1
2	90003509	Bottom T-Washer	1
3	99751006	3/4"-16 x 3 1/2" Bolt	1
4	99752005	3/4"-16 Lock Nut	1

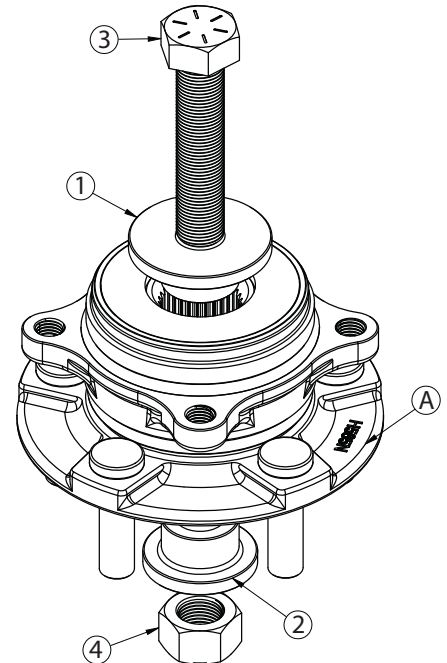

If replacing the hubs in the future, the center bolt and t-washers will need to be installed in the new hub. Torque the 3/4" bolt and nut to 200 ft-lbs.

Major Components AssembledIn the box

LOWER CONTROL ARM ASSEMBLIES

Exploded View on Page 6

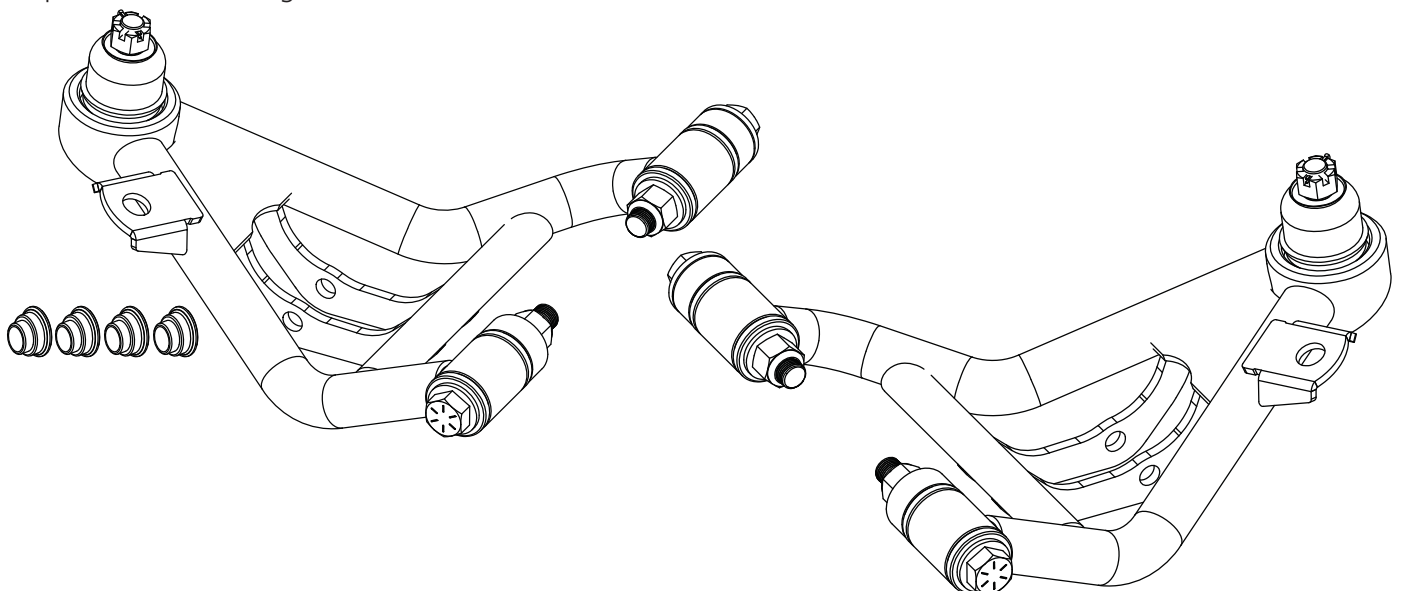



Major Components AssembledIn the box

UPPER CONTROL ARM ASSEMBLIES

Exploded View on Page 6

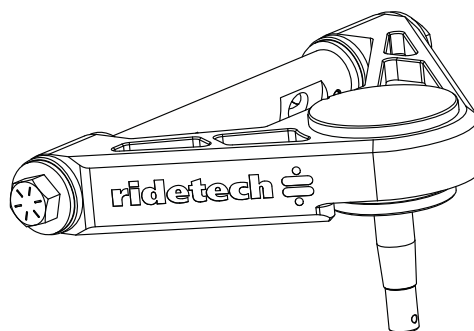
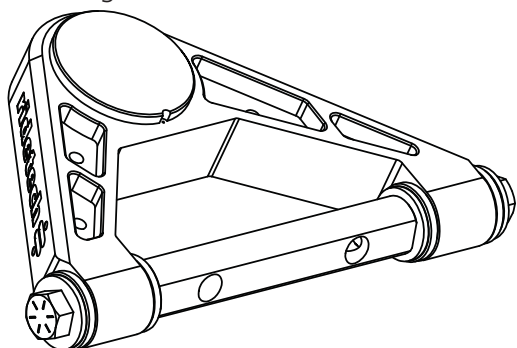

AFTERMARKET K-MEMBER FRAME SURROUND KIT

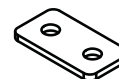
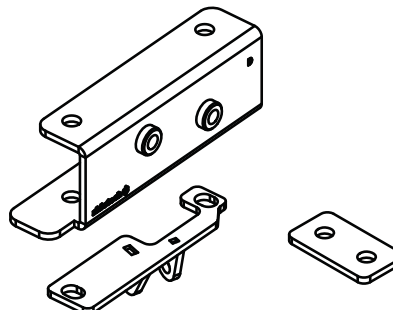
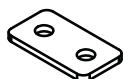
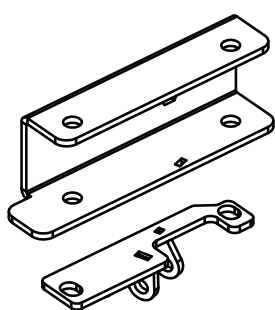

SPINDLES

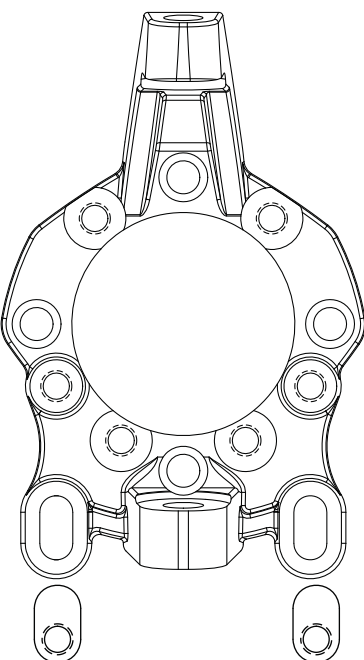
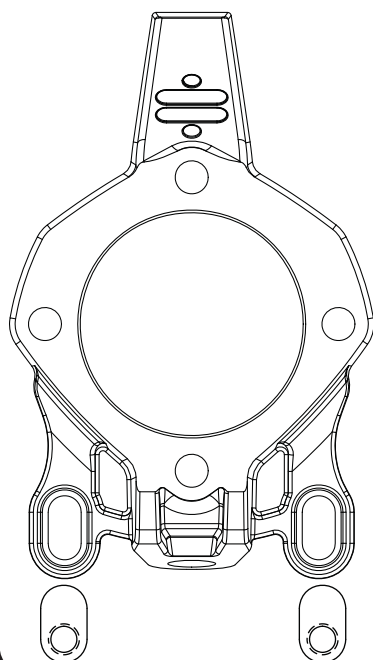

HUB KIT

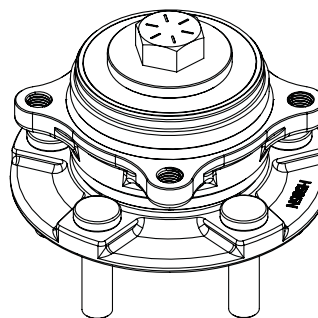
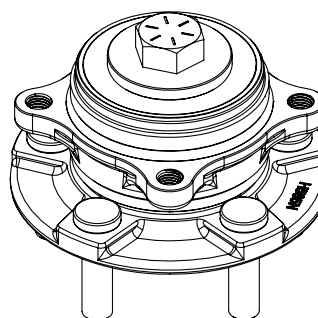



Major ComponentsIn the box

Item #	Part Number	Description	QTY	
1	11009311	Hub Bearing Spindle Kit	1	
	1a	70015751	Hub Spindle	2
	1b	90003535	Steering Arm Threaded Slug	4
	1c	99121018	M12-1.5 x 40mm Socket Head Cap Screw	8
2	12129501	Bearing Hub Assembly	2	
3	90003429	Upper Control Arm - Driver	1	
4	90003430	Upper Control Arm - Passenger	1	
5	90003848	Upper Ball Joint	2	
6	90003431	Upper Cross Shaft	2	
7	90003484	Upper Control Arm Inner Bushing Sleeve	4	
8	70016277	Delrin Bushing Half	8	
9	90003481	Steering Arm - Driver	1	
10	90003482	Steering Arm - Passenger	1	
11	70016565	External Retaining Ring	2	
12	99501021	1/2"-20 x 2 3/4" Hex Bolt	4	
13	99503016	1/2" MIL Spec Washer	6	
14	99254002	1/4"-20 Set Screw	4	
15	90003486	Lower Control Arm - Driver	1	
16	90003487	Lower Control Arm - Passenger	1	
17	70016231	Delrin Bushing Half	8	
18	90003488	Lower Control Arm Inner Bushing Sleeve	4	
19	90003489	Lower Control Arm Spacer - .750" long	4	
20	90003490	Lower Control Arm Spacer - .200" long	2	
21	90000898	Lower Ball Joint	2	
22	90002043	Aluminum Shock Spacers, .500" ID x .365" long	8	
23	90003426	Frame Surround - Driver	1	
24	90003427	Frame Surround - Passenger	1	
25	90003479	Upper Shock Mount - Driver	1	
26	90003480	Upper Shock Mount - Passenger	1	
27	90003428	K-Member Spacer	2	
28	90003400	Tie Rod Adjuster	2	
29	90003483	Outer Tie Rod Stud	2	
30	90002676	Tie Rod Spacer - .125" Thick	8	
31	90003501	Tie Rod Spacer - 1.00" Thick	2	
32	90003502	Tie Rod Spacer - .070" Thick	2	
33	90001582	Outer Tie Rod Heim End	2	



Cradle and Steering ComponentsIn the box

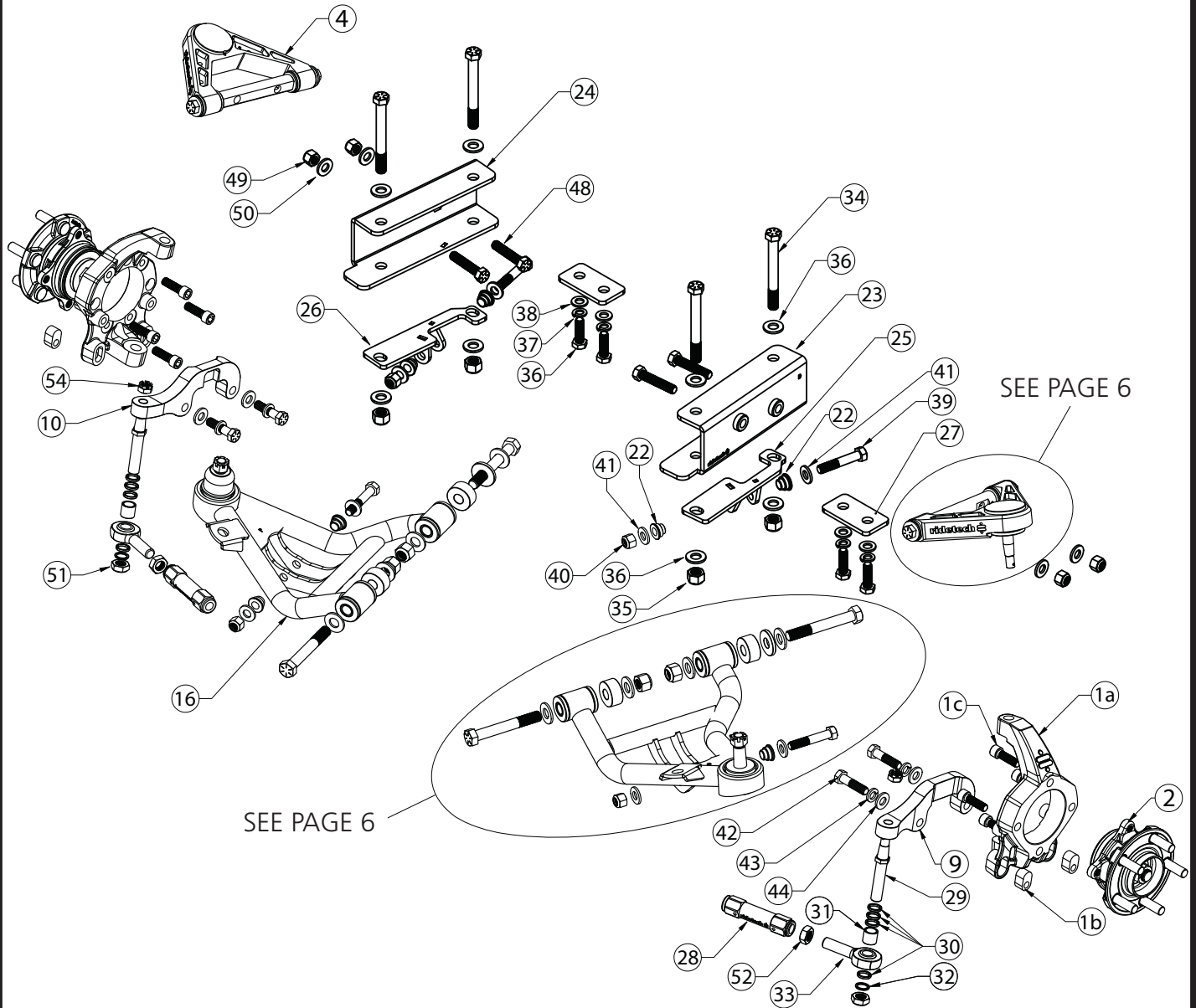



Control Arm ComponentsIn the box

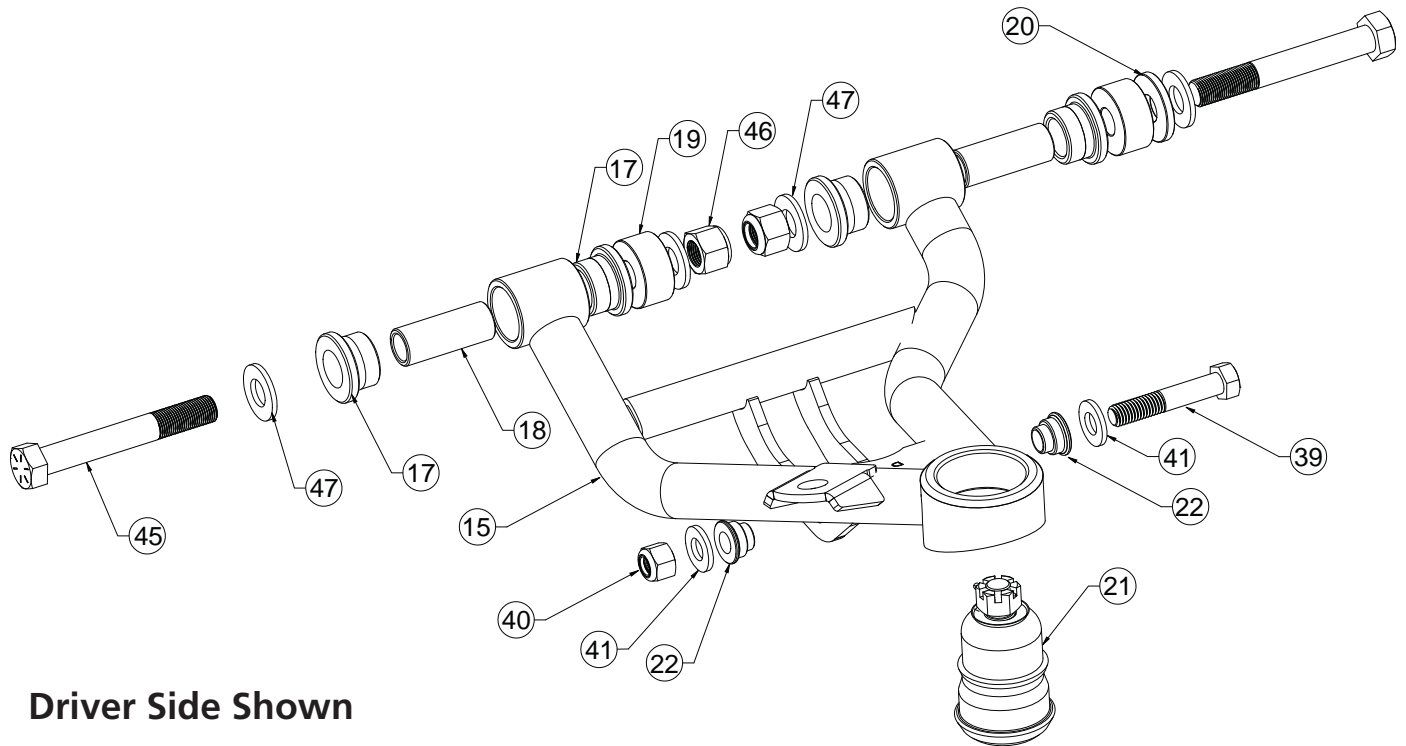

Driver Side Shown

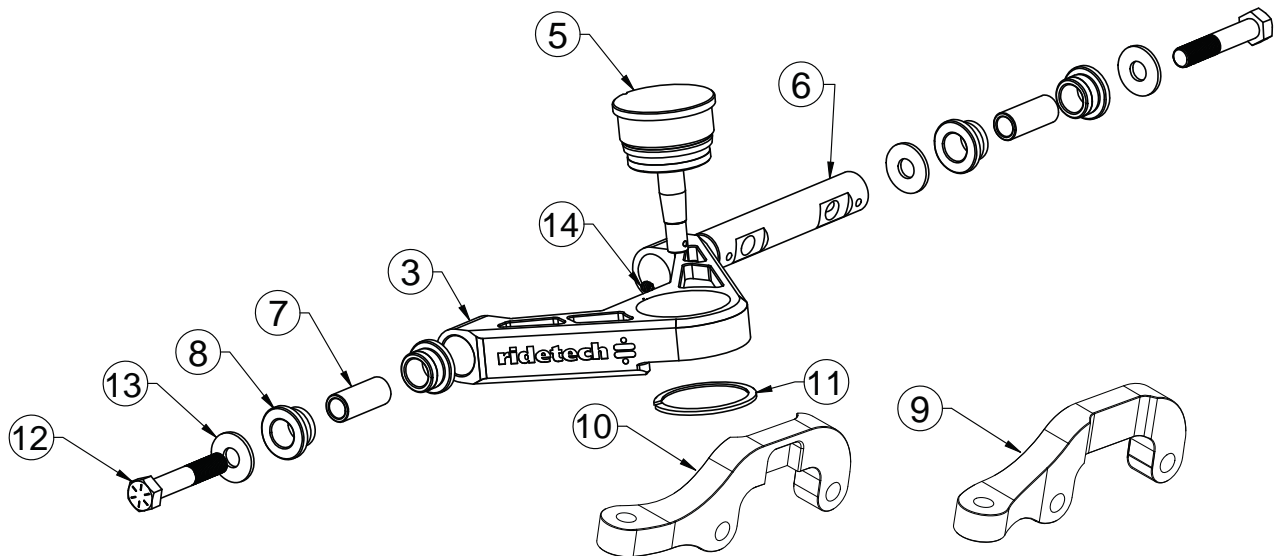

Driver Side Shown



Main Hardware Kit#99010224

THIS KIT INCLUDES A HARDWARE KIT. THE KIT IS BROKEN DOWN ON THIS PAGE. THE HARDWARE KIT IS LABELED AND BAGGED ACCORDING TO THE LOCATION THEY ARE USED. THIS LIST, ALONG WITH THE DIAGRAMS ON THE PREVIOUS PAGES, WILL HELP GUIDE YOU WITH THE KIT INSTALLATION.

Item #	Part Number	Description	QTY	Item #	Part Number	Description	QTY
FRAME SURROUND TO FRAME				STEERING ARMS TO SPINDLE			
34	99561004	9/16" -18 x 5" Hex Bolt	4	42	99501043	1/2" -13 x 2" Hex Bolt	4
35	99562011	9/16" -18 Nylok Nut	4	43	99503015	1/2" Split Lock Washer	4
36	99563003	9/16" Flat Washer	8	44	99503014	1/2" SAE Flat Washer	4
K-MEMBER SPACER TO FRAME				LOWER CONTROL ARM TO K-MEMBER			
36	99125004	M12-1.75 x 40mm Bolt	4	45	99621015	5/8" -18 X 4 1/2" Hex Bolt	4
37	99123001	M12 Split Lock Washer	4	46	99622001	5/8" -18 Nylok Nut	4
38	99123002	M12 Flat Washer	4	47	99623010	5/8" SAE Flat Washer	8
SHOCK MOUNTS				FRAME SURROUND TO UPPER CONTROL ARM			
39	99501064	1/2" -13 x 2 3/4" Hex Bolt	4	48	99501073	1/2" -13 x 2 1/2" Hex Bolt	4
40	99502009	1/2" -13 Nylok Nut	4	49	99502009	1/2" -13 Nylok Nut	4
41	99503014	1/2" SAE Flat Washer	8	50	99503014	1/2" SAE Flat Washer	4

Bump Steer Kit#99010228

BUMP STEER				BUMP STEER			
51	99622006	5/8" -18 Nylok Jam Nut	2	53	99952003	Cotter Pin	2
52	99800003	5/8" -18 Left Hand Jam Nut	2	54	99502017	1/2" -20 Castle Nut	2

Important Notes

The K-member will need to be lowered to install this kit. When supporting the vehicle, make sure to support it by the frame areas to allow the front k-member to be lowered.

The spindle in this kit is designed to utilize 1994-2004 SN95 Mustang or 2015-2022 S550 Mustang front brakes. Each will require an adapter bracket kit to attach the caliper to the spindle.

SN95 Mustang Caliper Bracket Kit: 12129508

S550 Mustang Caliper Bracket Kit: 12129509

Wheel Fitment: This kit will require at least a 17" diameter wheel.

This kit may require some brake line modifications.

The brakes will need to be bled after installing new front brakes.

The k-member will need to be lowered slightly to install the frame surround. This will cause the engine to move downward some. If you are running aftermarket accessories, they may need to be disconnected if they will interfere with the lowering of the k-member.

Disassembly

1. You will be removing the front suspension from the car. This will include the lower control arms, coil springs, struts, and spindles.
2. Remove the entire front suspension from the car. Refer to the factory service manual for disassembly procedure.



Disassembly



3. Disconnect the outer tie rod end from the spindle.



4. Disconnect the rubber brake line from the hard-line at each front wheel.



5. Unbolt the OEM brake line mount from the frame.



Disassembly



6. The rack and pinion will need to be loosened to allow for removal of the front lower control arm bolt. Remove the rack attaching hardware.



7. The rack and pinion will also need to be disconnected from the steering linkage. The rag joint can only be installed one direction.

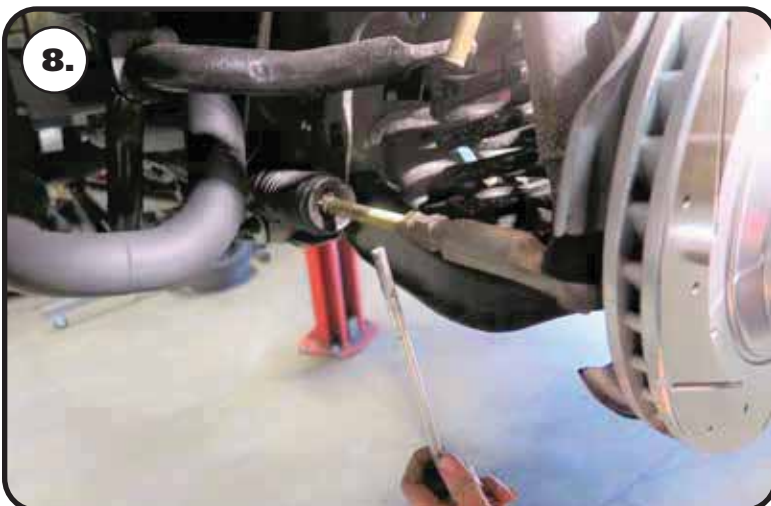

8. Disconnect the front sway bar from the lower control arm. Remove the sway bar linkage from both control arms. Retain the hardware for reassembly.



Disassembly



9. Support the lower control arm with a jack. You will need to be able to lower the jack to remove the coil spring. If your car has a coil over strut setup, loosen the preload on the coil spring. Remove the upper strut retaining nut.



10. Slowly lower the jack to unload the coil spring and remove it.



11. Unbolt the lower control arm from the k-member. Remove the spindle/ strut assembly from the car.



Disassembly



12. The k-member will need to be supported by a jack. You will need to be able to lower the k-member a little bit. You will unbolt one side at a time to help with the installation. Remove the (2) rear frame bolts. You will need to loosen the same (2) bolts on the other side.



13. Remove the (2) bolts from the coil spring area of the k-member. Loosen the same (2) bolts on the other side.



14. Lower the k-member approximately 1 1/2".



Frame Surround Installation



15. The horizontal flange at the top of the frame rail will need to be flattened. The flange can be flattened by cutting it and tapping it down with a hammer.



16. Hold the frame surround up to the flange to give yourself an idea where it needs to be cut. The shock mount will go on the bottom of the frame. Mark the flange just past the front edge of the frame surround.



17. Mark the frame flange just behind the frame surround.



Frame Surround Installation



18. We used a die-grinder with a cutoff wheel to cut the flange. Make sure the cut is even with the vertical surface of the frame rail.



19. Again, cut the rear of the flange even with the vertical surface of the frame rail.



20. Use a hammer to tap the flange down against the vertical face of the frame rail.



Frame Surround Installation



21. The flange needs to be flat against the vertical face of the rail.



22. You may need to tap the top surface of the rail down.



23. The kit contains a Driver and Passenger frame surrounds. They are marked "D" for Driver and "P" for Passenger. **Image 23 shows the Driver side.** Make sure the bracket will slip over the frame rail and align with the k-member mounting holes.



Frame Surround Installation



24. Install a 1/2"-13 x 2 1/2" in each of the upper control arm mounting holes of the frame surround. The hex head of the bolt needs to be inserted into the hex of the frame surround.



25. Install the frame surround in place. It should align with the OEM holes of the frame.



26. Install a 9/16" flat washer on each of (2) 9/16"-18 x 5" hex bolts. Insert the bolt/washers through the frame surround and frame rail.



Frame Surround Installation



27. Jack the k-member up while aligning it with the bolts sticking through the frame/surround. Install a 9/16" flat washer & 9/16"-18 nylok nut on the threads of each bolt. Do NOT tighten the bolts at this time.



28. Insert the 2 hole shim between the rear tab of the k-member and the frame.



29. Insert the 2 hole shim between the rear tab of the k-member and the frame.



Frame Surround & Lower Control Arm Installation



30. Install a M12 split lock washer and M12 flat washer on each of (2) M12-1.75 x 40mm bolt. Insert a bolt/washer in each slot and thread it into the OEM frame. Do NOT tighten at this time. The hardware needs to be left loose to install the frame surround on the passenger side.

Repeat **Steps 3-32** on the Passenger side.



31. Torque the 9/16" k-member mounting hardware to 89 ft-lbs. Torque the M12 k-member mounting hardware to 72 ft-lbs.

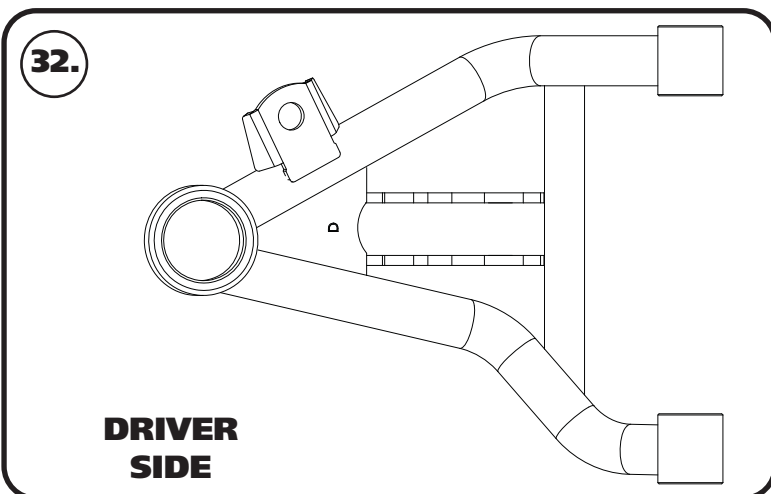

32. You may have to pull the bolt out of the bushing slightly to be able to insert the spacers. Slip the spacers in place and push the bolt through the bushing and spacer.



Lower Control Arm Installation



33. Torque the 9/16" k-member mounting hardware to 89 ft-lbs. Torque the M12 k-member mounting hardware to 72 ft-lbs.



34. The lower control arms are marked "D" for Driver and "P" for Passenger. The ball joint pin points up and the sway bar mount is on the front side of the arm. **Diagram 32** shows a top view of the Driver lower control arm.



35. Insert the control arm in the OEM lower control arm mounts. Install a 1/2" flat washer on each of (2) 1/2"-13 x 4 1/2" hex bolts. Insert the bolt/washer in the aligned holes with the threads to the rear of the car. The lower control arms in this kit are designed to fit the OEM and some aftermarket k-members. To make them fit several k-members, the lower control arm bushings will require spacers on the rear side of the bushing in the OEM k-member.



Upper Control Arm Installation



36. The front control arm bushing will require a .750" spacer on the rear side of the bushing. You may have to pull the bolt out of the bushing slightly to be able to insert the spacer. Slip the spacer in place and push the bolt through the bushing and spacer.



37. The rear bushing will require a .750" & .200" thick spacer on the rear side of the bushing.



38. You may have to pull the bolt out of the bushing slightly to be able to insert the spacers. Slip the spacers in place and push the bolt through the bushing and spacer.



Lower Control Arm & Shock Installation



39. Install a 1/2" flat washer & 1/2"-13 nylok nut on the threads of the bolts. Torque the mounting bolts to 75 ft-lbs.

If installing CoilOvers, refer to the CoilOver instructions for shock assembly.



40. Insert the shock bearing t-bushings into the bearing of the eyelet. The small outside diameter of the t-bushing will insert into the shock bearing.



41. Insert the eyelet of the shock into the frame mount with the adjuster knob toward the outside of the car. Align the mounting holes with the through hole of the shock eyelet.



Shock Installation



42. Install a 1/2" flat washer on a 1/2"-13 x 2 3/4" hex bolt. Insert the bolt/washer into the mount/shock. Install a 1/2" flat washer & 1/2"-13 nylok nut. Torque the hardware to 75 ft-lbs.



43. Insert the shock bearing t-bushings into the bearing of the shock body. The small outside diameter of the t-bushing will insert into the shock bearing.



44. Swing the lower control arm up to the shock. While swinging the control arm up, insert the shock body into the shock mount of the control arm. Align the mounting holes with the through hole of the shock body.



Shock & Upper Control Arm Installation



45. Install a 1/2" flat washer on a 1/2"-13 x 2 3/4" hex bolt. Insert the bolt/washer into the mount/shock. Install a 1/2" flat washer & 1/2"-13 nylok nut. Torque the hardware to 75 ft-lbs.

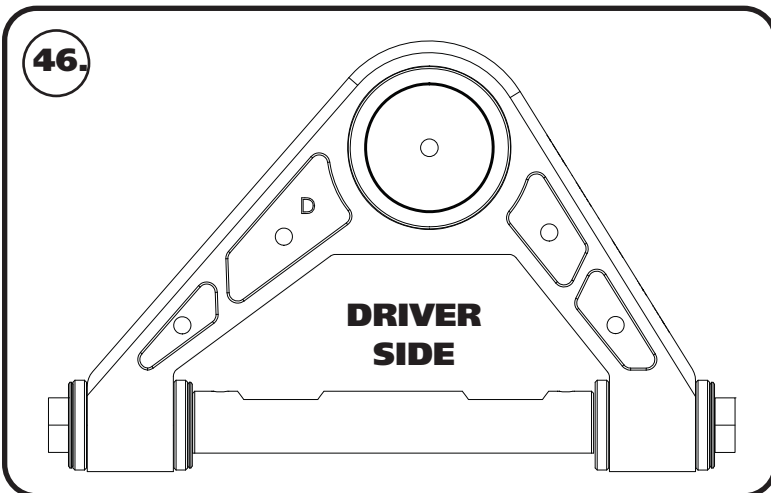

46. The upper control arms are marked "D" for Driver and "P" for Passenger. The ball joint pin points down and the ball joint is to the front of the car. **Diagram 46** shows a top view of the Driver upper control arm.



47. Slip the control arm onto the (2) mounting bolts that stick out of the frame surround. The flat side of the cross shaft needs to go against the frame surround.



Upper Control Arm & Spindle Installation



48.

48. Slip a 1/2" flat washer on the threads of each bolt. Thread a 1/2"-13 nylok nut on each bolt. Torque the nuts to 75 ft-lbs.

THESE SPINDLES ARE SYMMETRICAL, THEY AREN'T SIDE SPECIFIC UNTIL THE STEERING ARM IS BOLTED ON.



49.

49. Install the spindle on the lower ball joint. Install the ball joint castle nut on the stud of the ball joint.

Torque Specs:

Lower Ball joint - 65 ftlbs and tighten to line up cotter pin.

Install the Cotter Pin after tightening the ball joint nut.

Note: This Image shows the steering arm installed, but they shouldn't be installed until the caliper brackets are installed.



50.

50. Insert the top ball joint into the spindle.

Torque Specs:

Upper Ball Joint - 50 ftlbs and tighten to line up cotter pin.

Install the Cotter Pin after tightening the ball joint nut.



Hub Bearing Installation



51. The Hub is attached to the spindle using (4) M12-1.50 x 40 SHCS. Apply RED Loctite to each of the mounting bolts. Insert them into the correct holes and Torque to 99 ftlbs.



The steering arms will **NOT** get attached to the knuckle until the brakes are attached. Refer to the caliper bracket instructions for proper assembly.

Caliper Bracket Installation

Caliper bracket and brake mounting will differ depending on the brake kit being used. Refer to the caliper bracket kit instructions.

We recommend mocking up the brakes with clean dry threads before applying any loctite to the hardware.

The brake bracket kits include shims for mounting the caliper brackets and calipers. The caliper brackets will use 1/2" ID shims. The caliper spacers will use 5/8" ID shims.

Again, mock up the brake kits with clean dry threads before using any loctite on the hardware. We are showing the installation of the caliper bracket with the spindle off the car so it can be shown clearly.

Steering Arm Installation

The threaded steering arm inserts can be mounted in 2 different positions. **Image 52** will help you determine the correct position for the installation on your vehicle. This position is what we determined to be the best with the Ridetech suspension.

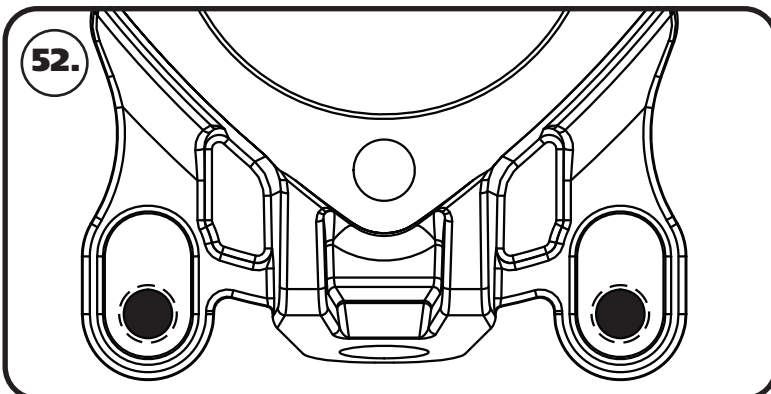

52. Bottom Position:
79-93 Mustang SLA Suspension



Steering Arm Installation



The next 3 Images are shown with the spindle off the car to show greater detail.

53. Insert the steering arm slugs into the spindle with the threads to the bottom of the spindle,

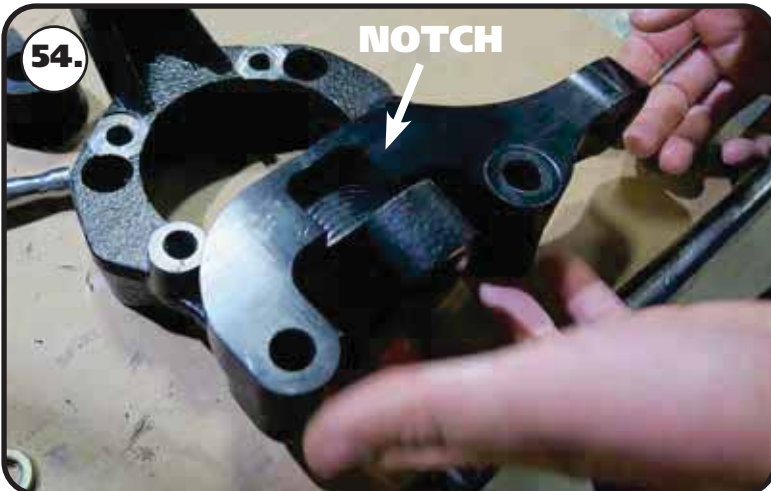

54. Flip the spindle over while holding the steering arm slugs in place. Align the mounting holes of the steering arm with the threaded holes of the slugs. Driver side steering arm is shown in Image 50. Notice the notch for ball joint nut clearance. The tie rod end curves out to the outside of the car.



55. Install a 1/2" split lock washer & 1/2" flat washer on each of (2) 1/2"-13 x 2" hex bolts. Insert a bolt in each steering arm hole and thread them into the steering arm slugs. Torque to 80 ft-lbs. Repeat on other steering arm/spindle.



Steering Linkage Installation



56. Remove the OEM tie rod end, leaving the OEM jam nut threaded on the inner tie rod.



57. The tie rod adjuster has 2 threads in it; 9/16"-18 RH & 5/8"-18 LH. The 5/8"-18 LH thread is marked with a groove on the outside of the adjuster. The 9/16-18 RH end of the adjuster will thread onto the OEM inner tie-rod. You should use anti seize when threading the heim ends into the adjuster. Thread the 5/8" 18 LH jam nut onto the heim in that is supplied in the kit. Thread the heim into the tie rod adjuster. **FOR YOUR SAFETY, THE TIE ROD & HEIM NEED A MINIMUM OF 15/16" OF THREAD ENGAGEMENT INTO THE TIE ROD ADJUSTER.**



58. Install the stud with the round flange into the steering arm with the taper going into the steering arm. Torque the nuts to 35 ftlbs and tighten as needed to align cotter pin hole and install cotter pin.



Outer Tie Rod Installation



59. Torque the nuts to 35 ftlbs and tighten as needed to align cotter pin hole and install cotter pin.



60. Use the guide on **Page 28** to help determine the shims needed for the outer tie rod. We did a fitment on Maximum Motorsports and Team Z k-members. If you are using a different brand of k-member, we recommend checking the bumpsteer on the car. Insert the required shims, followed by the outer tie rod heim end.

Note: Some aftermarket k-members may require offset rack bushings to raise or lower the rack mounting position to help optimize the bumpsteer.



61. Install the 5/8" ID x .070" spacer on the stud followed by a 5/8"-18 mechanical locking nut. Torque to 45 ftlbs.



Outer Tie Rod Shimming Guide

Maximum Motorsports (with Maximum Motorsports Solid Rack Bushings)

Rack Position	Total Spacer Height	3/4" Shim	1/8" Shim
3/8" Raised	3/8"	0	3
1/4" Raised	1/2"	0	4
Centered	3/4"	1	0
1/4" Lowered	1"	1	2
3/8" Lowered	1 1/8"	1	3

Team Z Team Z steering rack mounts are offset 7/8" to the passenger side. We recommend Prothane offset rack bushings # 6-704-BL to reduce the offset to 1/2".

Rack Position	Total Spacer Height	3/4" Shim	1/8" Shim
Centered	1 1/4"	1	4

For all K members it is recommended to use steering rack limiters to keep the tire out of the inner fenders/frame rails.

Sway Bar Installation



62. Reattach the sway bar to the lower control arms.

Finishing & Alignment

63. Double check the hardware to make sure everything is tight.
64. Attach the steering column to the rack and pinion.
65. Plumb the front brakes and bleed them.
66. The car will need to be aligned.

Suggested Alignment Specs:

Camber: Street:	- .5 degrees
Caster: Street:	+3.0 to + 5.0 degrees
Toe: Street:	1/16" to 1/8" toe in