

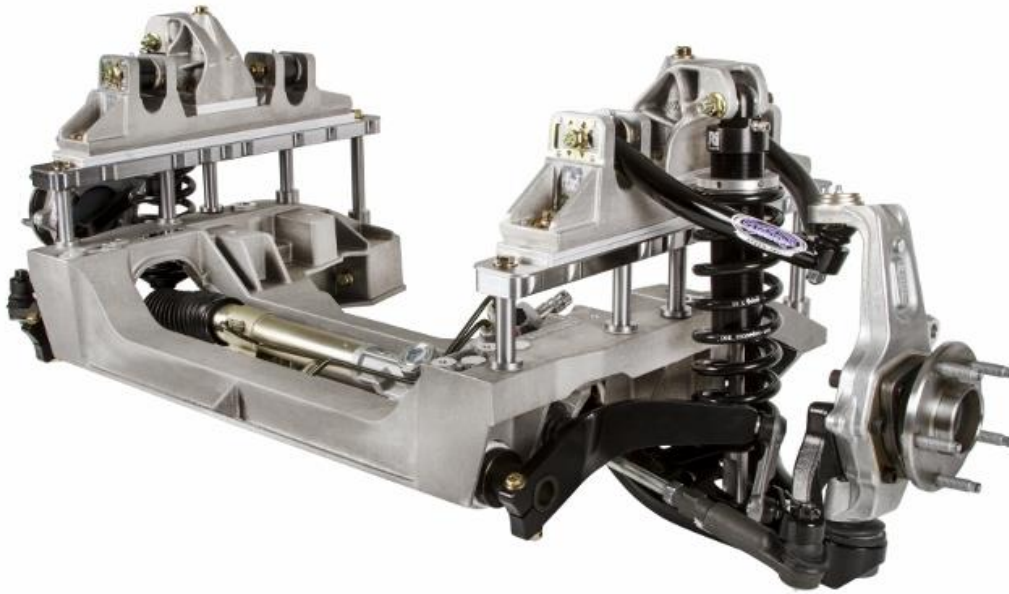



Detroit Speed, Inc.
ALUMA-Frame Front Suspension System
1964.5-1970 Ford Mustang
P/N: 032050

All aluminum front suspension system for 1964.5 -1970 Mustangs featuring Detroit Speed's unique suspension geometry with 6" of suspension travel for the ultimate in ride and performance. The Detroit Speed ALUMA-Frame Suspension System has been designed, engineered, and developed for the road and track. This system blends the benefits of current OEM technology and aftermarket performance into one product.



The Detroit Speed Mustang ALUMA-Frame has the following features:

- Unique cast aluminum cradle and mounting components resulting in a high strength to weight ratio and precise fitment
- Tubular upper and lower control arms
- Detroit Tuned rack and pinion steering
- Made in the U.S.A. 
- Detroit Speed/JRi high performance monotube aluminum coilover shocks available in fixed valve, single adjustable, double adjustable, or remote canister double adjustable versions
- Splined anti-roll bar
- Detroit Speed's patent pending Speed-LIGN caster/ camber adjusters allow a wide range of adjustability to be made precisely and quickly without the need for additional components
- Utilizes forged aluminum uprights and hub packs with a Ford bolt pattern
- Can fit up to P265/35R18 tires on a 9" rim on early models and up to P295/35R18 tires on a 10.5" rim on later models with no fender modifications
- Retains stock framerails and inner fenders
- Engine mount kits available for Ford small block Windsor engines, Ford FE big block engines, Ford 4.6, 5.4, Coyote 5.0 modular engines, Boss 302 engines, and GM LS series engines

NOTE: The Aluma-Frame will need to be modified to clear the alternator on any Ford modular engine that has the alternator mounted low on the right hand side of the engine block. The alternator bracket will also need to be modified to move the alternator closer to the center of the vehicle. Detroit Speed offers an alternator relocation bracket, P/N: 060436 for Coyote engines only that will be required along with modifying the Aluma-Frame to fit the Coyote engine. See Step 3 on page 7 for Aluma-Frame for modifications. There is also a print attached to the last page of these instructions to show the modifications.

Detroit Speed recommends using the following parts with your engine installation:

- CR3Z10346A – Ford Alternator
- BR3Z6B209H – Ford Tensioner
- BR3Z8620D – Ford Serpentine Belt

NOTE: All work should be performed by a qualified welder and technician.

NOTE: There is an installation video available through the Detroit Speed website in the tech/install video shown here: <https://www.detroitsspeed.com/1964-5-70-mustang-installation-videos>.

Specifications-Detroit Speed Mustang ALUMA-Frame Front Suspension	
Flange to Flange Distance (without rotors)	56.9"
Flange to Flange Distance (with rotors)	57.7"
Total Suspension Travel	6"
Ride Height*	1.0" ±1.0"
Static Camber	-0.5° ±.2°
Static Caster	8.0° ±.5°
Static Toe	0° ±.1°
Total Bumpsteer (28" toe span)	.070"
Turning Angle	27°
Ackerman Angle (@ 15° turning angle)	.875°
Spring Rate	400lb/in
Spring Free Length	10"

*Measured up from the bottom of the framerrail to the center of the hub

Wheel Fitment-Detroit Speed Mustang Front Suspension 1964.5-66					
Diameter (in)	Width (in)	Backspacing (in)	Bolt Pattern/ Lug Nut Thread Pitch	Recommended Tire	Comments
17	8.0	5.5	5 X 4.5" 1/2"-20 UNF	245/40R17	
	8.5	5.75		245/40R17	Maximum width recommended
18	8.0	5.5		245/35R18	
	8.5	5.75		245/35R18	
	9.0	6		265/35R18	Maximum width recommended

Wheel Fitment-Detroit Speed Mustang Front Suspension 1967-68					
Diameter (in)	Width (in)	Backspacing (in)	Bolt Pattern/ Lug Nut Thread Pitch	Recommended Tire	Comments
17	8.0	5	5 X 4.5" 1/2"-20 UNF	245/40R17	
	8.5	5.25		245/40R17	
	9.0	5.5		255/40R17	Maximum width recommended
18	8.0	5		245/35R18	
	8.5	5.25		245/35R18	
	9.0	5.5		255/35R18	
	9.5	5.75		265/35R18	
	10.0	6		275/35R18	Maximum width recommended

Wheel Fitment-Detroit Speed Mustang Front Suspension 1969-70					
Diameter (in)	Width (in)	Backspacing (in)	Bolt Pattern/ Lug Nut Thread Pitch	Recommended Tire	Comments
17	8.0	5	5 X 4.5" 1/2"-20 UNF	245/40R17	
	8.5	5.25		245/40R17	
	9.0	5.5		255/40R17	Maximum width recommended
18	8.0	5		245/35R18	
	8.5	5.25		245/35R18	
	9.0	5.5		255/35R18	
	9.5	5.75		265/35R18	
	10.0	6		275/35R18	
	10.5	6		295/35R18	Maximum width recommended

Wheel fitment based on a .400" rotor hat thickness

*** 17" wheels require a minimum inside wheel diameter of 16.250"**

CAUTION: Some brake applications will not work with 17" wheels. Flush mount valve stems may also be required on wheels with a behind center valve stem location.

Accessory Components-Detroit Speed Mustang ALUMA-Frame Front Suspension	
Brakes	Detroit Speed offers Baer Brake kits
Subframe Connectors*	Detroit Speed P/N: 010105 (1964.5-70)
Torque Boxes	Detroit Speed P/N: 010107 (Detroit Speed Suspension), P/N: 010109 (Stock Suspension)
Rack & Pinion Fittings	High pressure: 9/16"-18 UNF Low pressure: 5/8"-18 UNF Fittings to adapt to -6 AN and complete hose kits are all available through Detroit Speed
Rack & Pinion Input Shaft	3/4"-36, Complete kits available through Detroit Speed

*Requires Torque Boxes

Engine Fitment – Detroit Speed Aluma-Frame

Engine	Mounting	Oil Pans	Headers	Comments
Small Block Ford – 289/302 Base (8.2" Deck)	Use Detroit Speed kit P/N: 060421	289/302 use Canton P/N: 15-640 or 15-644 rear sump pan	JBA Headers: P/N: 1650S	
Small Block Ford – 351W Base (9.5" Deck)	Use Detroit Speed kit P/N: 060421	Detroit Speed P/N: 060203 pan	Headman Headers: P/N: 88650	Detroit Speed P/N: 060203 oil pan includes Canton pick-up tube
Big Block Ford Ford "FE"	Use Detroit Speed kit P/N: 060422	Use Canton P/N: 15-874 rear sump pan Use Canton P/N: 15-875 for pick-up tube	Custom	
4.6, 5.4 Modular	Use Detroit Speed kit P/N: 060420	Use Canton P/N: 15-794 Use Canton P/N: 15-795 for pick up tube	Custom	Modular engines require removal of stock shock/spring towers. 5.4 engine requires brake booster/ master cylinder relocation
5.0 Coyote	Use Detroit Speed kit P/N: 060420	Use Canton P/N: 15-736 Use Canton P/N: 15-737 for pick-up tube	Detroit Speed Headers P/N: 061005	Modular engines require removal of stock shock/spring towers. Detroit Speed recommends Motorcraft FL-8205 or Ford Racing M-6731-8205 oil filter. Requires alternator relocation bracket, P/N: 060436 along with Aluma-Frame modification.
GM LS Series	Use Detroit Speed kit P/N: 060423	LS1, LS2, & LS3: LS2/LS3 Corvette GM P/N: 12624617 4th Gen F-Body GM P/N: 12628771 Mast P/N: 401-111 Champ P/N: LS1000 Holley P/N: 302-2 LS7 & LS9: Corvette Dry Sump Pan GM P/N: 12626225	Custom	

Fastener Torque Specifications – Detroit Speed Mustang ALUMA-Frame		
Application	Torque (ft-lb)	Threads
Cradle 7/16"-14 Mounting Bolts	65	
Cradle 1/2"-13 Mounting Bolts	70	
Cradle 3/8"-16 Mounting Bolts	30	
Lower Control Arm Mounting Bolts	65	
Rack and Pinion Mounting Bolts	75	Anti-Seize
Sway Bar Shaft Clamp Screw	14	Blue Loctite 242
Upper Control Arm Mount Bracket Bolts	50	
Coilover Mount 7/16"-14 Bolts	65	
Coilover Mount 5/16"-18 Bolts	25	
Sway Bar Link Nuts	45	Red Loctite 262
Upper Control Arm Mounting Bolts	35	Red Loctite 262
Upper Coilover Shock Mounting Bolts	60	Anti-Seize
Lower Coilover Shock Bolts	60	Anti-Seize
Sway Bar Arm Mounting Bolt	25	
Tie Rod End Jam Nut	45	Anti-Seize
Upper Control Arm Ball Joint Stud Nut*	40	
Lower Control Arm Ball Joint Stud Nut*	20 then turn an additional 180°	Red Loctite 262
Tie Rod End Stud Nut*	35	Anti-Seize
Wheel/Hub Bearing Mounting Bolts	95	Red Loctite 262
Steer Arm Mounting Bolts	60	Red Loctite 262
Front Brake Caliper Mounting Bracket Bolts	125	
Wheel Stud Nuts	100	
*Always tighten slotted nuts to line up with the cotter pin hole when applicable.		

IMPORTANT:

1. The upper and lower control arms **CAN NOT** be powder coated a different color other than the way they are shipped since they come already assembled from Detroit Speed. The temperatures from this process will destroy the control arms beyond repair.

The Detroit Speed upper control arms **CAN NOT** be taken apart because of the precise assembly procedure at Detroit Speed. The upper control arm cross shaft nuts are torqued and then pinned in place. Failure to follow the correct procedure will damage the upper control arms beyond repair. Any attempt at taking apart any of the Detroit Speed subframe components before calling Detroit Speed will void any warranty. If you have any questions please call Detroit Speed at 704-662-3272.

2. If the lower control arm ball joint stud needs to be serviced after the initial torque setting listed above for a coilover spring change, etc. use the following information to re-assemble the lower control arm and upright:
 - a) Before you remove the ball joint nut, make a line with a marker from the top of the nut down to the upright and then loosen the ball joint nut.
 - b) Upon re-assembly, torque the ball joint nut to 20 ft-lbs. and then tighten the nut until the line on the nut goes back to the line on the upright so it is back in the same location as the initial torque setting.
3. If the upper ball joint needs to be replaced, the Detroit Speed upright assembly must be returned to Detroit Speed to be serviced. Failure to follow this procedure before calling Detroit Speed will void any warranty. If you have any questions please call us at 704-662-3272.

Installation:

1. Prepare the vehicle.

- a) Remove the engine and the entire front suspension and steering, including the original tubular crossmember and steering box.

2. Prepare the framerails.

- a) Carefully cut out the original rear lower control arm, factory anti-roll bar and engine mount brackets by drilling out and/or grinding the original spot welds. Cut around and leave the sections that go over the original tubular crossmember mounting nuts underneath the framerails. Leave the lower control arm front strut rod and anti-roll bar mounting brackets in place (Figure 1).



Figure 1 - Remove Factory Brackets

- b) Remove the original strut towers by cutting them flush with the inner fenders. Additional clearance for the upper control arm will be needed at the rear of the openings. 29-1/2" rearward from the front core support make a vertical cut up from the framerail flange and blend into the original strut tower opening. Make a vertical cut line at the front of the strut opening and blend into the original strut tower (Figure 2).



Figure 2 - Clearance Strut Tower Opening

- c) On the outside of the framerail, mark a horizontal line 3" up from the bottom flange of the framerail, the width of the strut tower opening (Figure 3). Cut the sheet metal along this horizontal line and connect the cut to the strut tower opening.

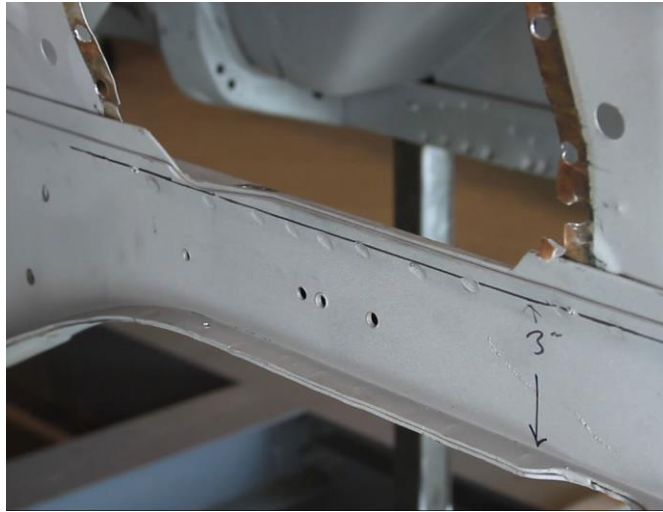

Figure 3 - Trim Framerail

- d) From the rear of the hole where the anti-roll bar bracket was located, measure back 1-1/8". Mark a cut line along the framerail brace that needs to be trimmed for the Aluma-Frame cradle (Figure 4). Remove that section of the brace and grind all sharp corners that were cut.



Figure 4 - Trim Framerail Brace

- e) If you are not using a Ford Coyote engine continue on to Step 4 on page 8, otherwise continue to Step 3.

3. Modify Framerail for Coyote Engine Fitment

- a) The left-hand framerail marked "L" will need to be modified, if not already from Detroit Speed, to clear the alternator once the engine is installed in the Aluma-Frame. If this part has already been modified from Detroit Speed, continue to step c). **NOTE:** The Detroit Speed alternator relocation bracket (P/N: 060436) is also required when using a Coyote engine.

- b) There is a 1/4" thick flange on the top side of the frameraill adapter. Trim 1/4" off the inside of the left-hand frameraill starting from the front edge and continue on about 9" back. **NOTE:** The front edge of left-hand frameraill is the side that has "L" engraved.
- c) Once the inside edge has been trimmed so that the inside surface is flush, place 1 of the upper control arm mount adjuster shims on top of the frameraill adapter. Line up the frameraill adapter and the shim using the bolt holes. Scribe a line onto the bottom side of the shim where you trimmed the frameraill adapter. Trim the adjuster shim to match the frameraill adapter. Repeat this process for a 2nd adjuster shim.
- d) Place the cast aluminum upper control arm mount on top of the frameraill adapter. Line up the frameraill adapter and the upper control arm mount and scribe along the bottom of the upper control arm mount where you trimmed the frameraill adapter. Trim the inside of the upper control arm mount to match the frameraill adapter. Continue up about 2-1/2" from the bottom surface of the upper control arm mount (Figure 5). **NOTE:** See page 34 for further details.



Figure 5 – Modify Frameraill Adapter, Adjuster Shims & UCA Mount

4. Mark the cradle hole mounting locations.

- a) Locate the original tubular crossmember mounting nuts along the bottom side of the frameraills. Use the 2 larger holes in the Aluma-Frame cradle along with the provided 1/2"-13 x 1-1/2"L flanged bolts, to bolt the Aluma-Frame to the vehicle. Adjust the cradle position so it's located in the center of and square to the vehicle frame and lightly tighten the 2 mounting bolts to hold it in place (Figure 6).

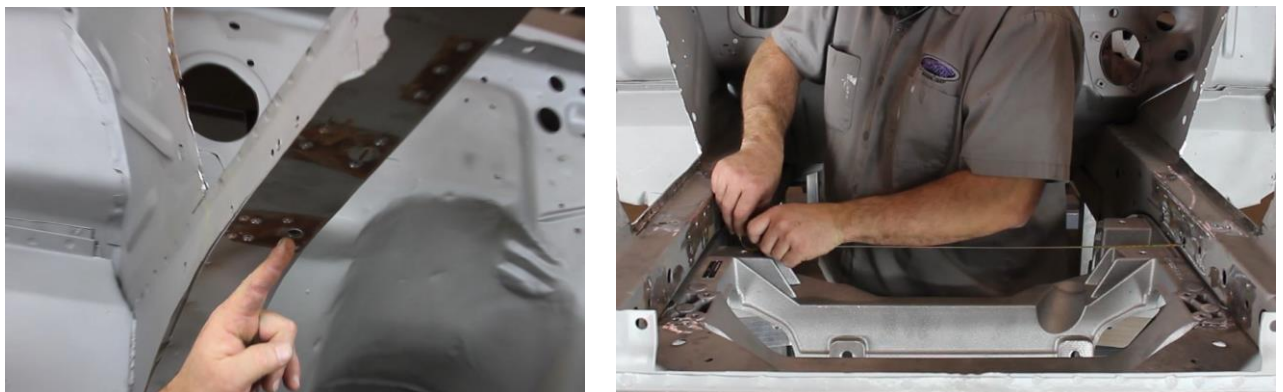

Figure 6 – Locate Aluma-Frame Cradle

- b) Check that the cradle mounts in the vehicle without interference; make clearance if necessary.
- c) Mark the cradle position elsewhere so it can be put back into position later after the mounting holes have been drilled out. Using the provided drill guide and extended 1/4" drill bit, drill through the top of the framerail from the bottom using the Aluma-Frame cradle as a template for 4 of the crush sleeve locations on each framerail (Figure 7). On later vehicles, the rear of the front lower control arm strut rod mounting brackets will need to be trimmed in order for the cradle to be put into position. Lightly snug the bolts so the cradle can be adjusted into the proper location.



Figure 7 - Locate Aluma-Frame Mounting Holes

5. Drill out the cradle hole mounting holes.

- a) Remove the 1/2"-13 flange bolts and remove the Aluma-Frame cradle from the vehicle so the mounting holes can be drilled.
- b) Drill out the front 2 holes on the bottom side of each framerail with a 1-1/8" hole saw. The rear 2 holes will need to be drilled out with a 1-5/8" hole saw. Deburr the cut areas. For the rear holes, the crush tubes inside the framerail for the original steering box and idler arm will need to be removed or cut through to make room for the Aluma-Frame framerail crush tubes (Figure 8).



Figure 8 - Drill-Out Bottom Frameraills

- c) Drill out all 4 holes on the top side of each framerail with a 1-1/8" hole saw (Figure 9). Deburr the cut areas.



Figure 9 – Drill-Out Top Framerais

- d) Place the framerail adapter plates on the top side of the framerail and align them with the mounting holes (Figure 10). The top side of each adapter plate has an “L” and an “R” marked at the front end of each plate so be sure to put them on the correct side. The front mounting hole is inboard of the other mounting holes. **NOTE:** The bottom sides of the framerail adapter plates have an angle cut into them to help relieve the inconsistencies of the factory framerails. There is a large radius at the outside edge at the top of the framerail as it rolls up to the flange that would keep the framerail adapter plate from sitting flat on the framerail. You may need to make additional modifications to the bottom of the framerail adapter plate to make sure it sits level on the framerail as each vehicle can vary.

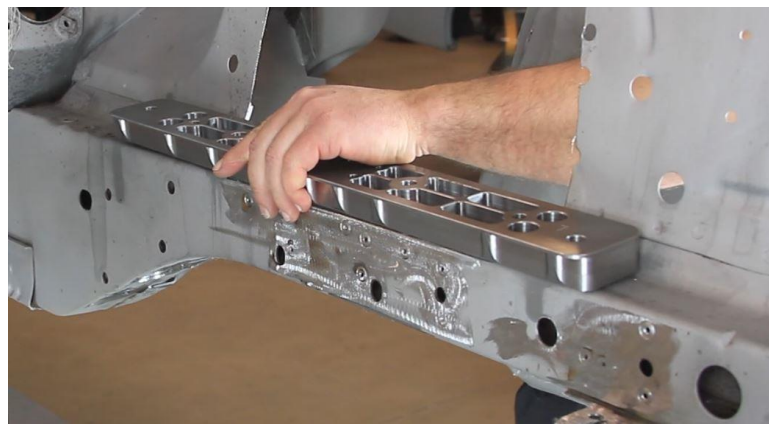

Figure 10 – Position Adapter Plate

- e) From the bottom side of the framerail, install the provided crush sleeves through the framerail and into the adapter plate. The front 2 crush sleeves are the same length and the rear 2 crush sleeves are longer going back to match the height of the framerail (Figure 11 on the next page). **NOTE:** The crush sleeves should thread in by hand, do not force them as you may damage the threads in the adapter plates. Because of the angle cut on the bottom, it may be difficult to start the crush sleeves into the adapter plates. Do not tighten the crush sleeves at this time. The purpose of this step is to check fitment; some of the holes may need to be modified slightly in order to get them all to line up.

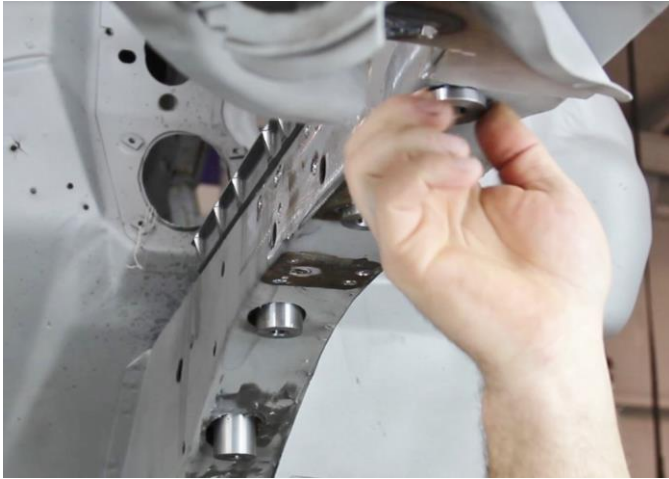

Figure 11 - Install Crush Sleeves

- f) With the crush sleeves holding the adapter plates in place, mark the position of the upper framerail mounting adapters so they can be reinstalled in the same position. Drill a pilot hole for the coilover crush sleeves through the framerails. Place the drill guide in the middle hole on the top side of the adapter plates and drill through the framerail with the extended 1/4" drill bit (Figure 12).

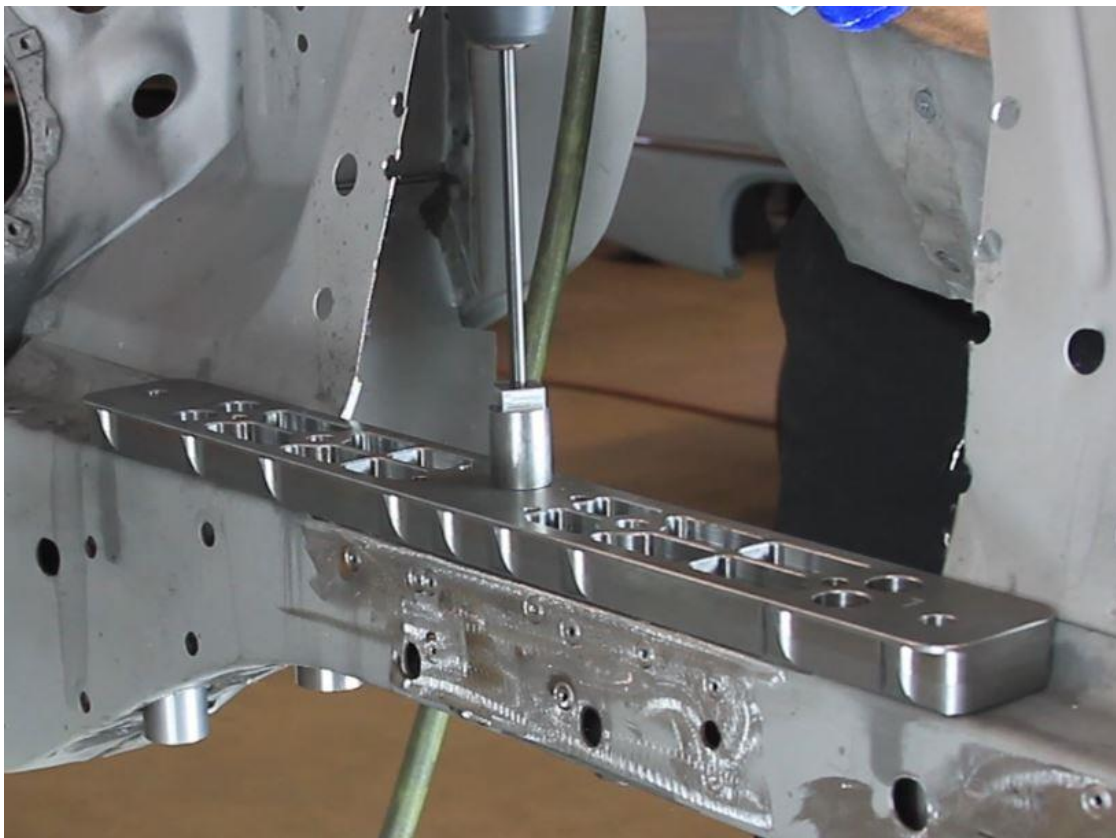

Figure 12 - Locate Coilover Crush Sleeve

- g) Remove the crush sleeves and adapter plates from the framerails. Using a 1-1/8" hole saw, drill through the top and bottom side of the framerails (Figure 13 on the next page). Remove the paint and clean the top and bottom of the framerails to prepare them for welding. Paint the framerails with weld-through primer.



Figure 13 - Drill-Out Frameraills

- h) Install the coilover crush sleeves through the bottom of the framerails and into the adapter plates. Re-install the other 4 crush sleeves in each framerail. Tighten all crush sleeves into the adapter plates (Figure 14). They should float in the framerails as they should not be tight or clamp against the framerails.



Figure 14 - Tighten All Crush Sleeves

6. Final installation of the framerail mounting adapter plates and crush sleeves.

- a) Position the Aluma-Frame cradle underneath the vehicle using the 1/2"-13 x 1-1/2"L flange bolts from the bottom side of the framerails. Center and square the cradle to the vehicle as in step 4a.

- b) Install the provided 7/16"-14 x 5-1/2"L bolts through the front 2 holes in the adapter plates. The 3rd hole from the front uses the 7/16"-14 x 6"L bolts and the rear hole uses the 7/16"-14 x 8-3/8"L flange bolts. Tighten the bolts using the provided 7/16"-14 flange lock nuts (Figure 15).



Figure 15 - Install Aluma-Frame Cradle Hardware

- c) Verify that the adapter plates and the top of the framerails are level. Tack weld the adapter plates to the top of the framerails. Tack weld the crush sleeves in place to the bottom of the framerails (Figure 16).

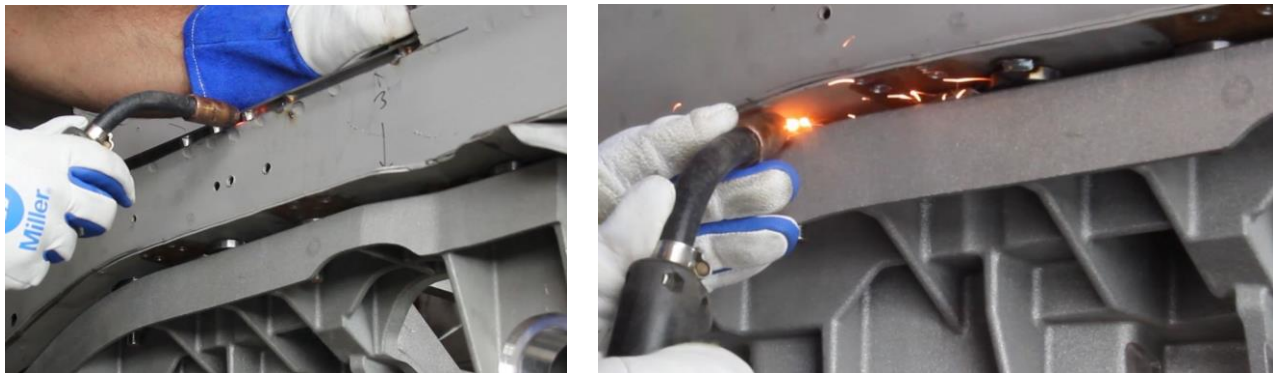

Figure 16 - Tack Weld Adapter Plates & Crush Sleeves

- d) Remove the Aluma-Frame cradle from the vehicle and finish weld the crush sleeves to the framerails. Weld the front edge of the adapter plates to the framerails. Plug weld the adapter plates to the framerails through the 12 machined pockets in each adapter plate. Finish weld the inboard perimeter of the adapter plates to the framerails (Figure 17).



Figure 17 - Finish Weld Adapter Plates & Crush Sleeves

7. Install the jounce bumper brackets.

- a) Measure back 14" and 7-1/4" from the front edge of the adapter plates and mark the outer framerails. At the 14" mark, draw a cut line along the seam at the bottom of the framerails. Draw a vertical centerline on the outer framerails at the 7-1/4" mark. Draw another cut line along the framerail edge to be removed. Cut this section of the outer framerails (Figure 18).

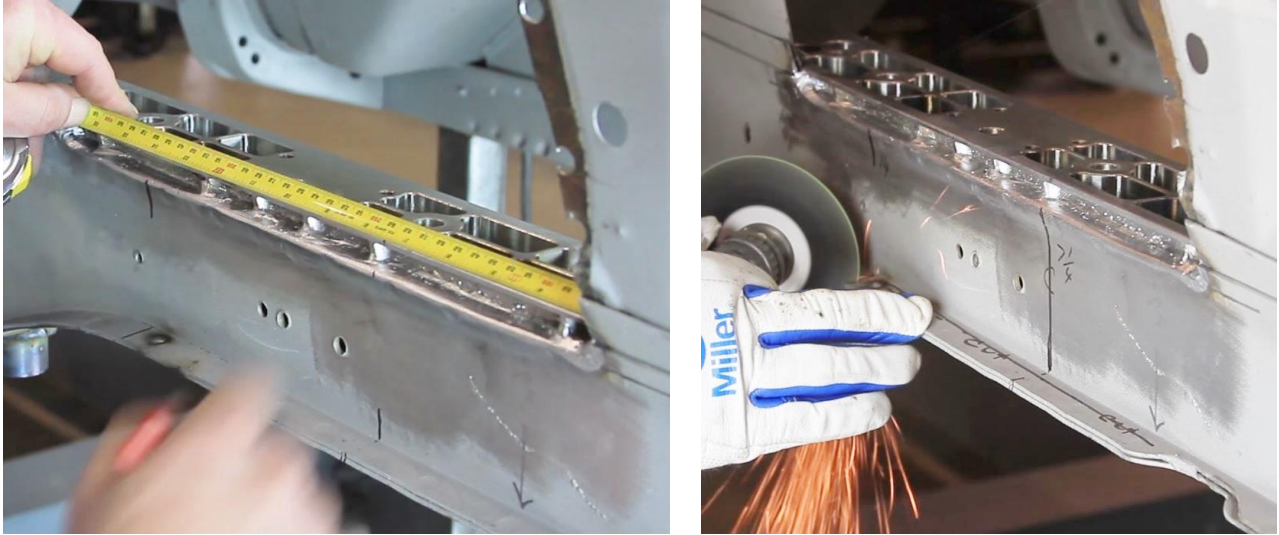

Figure 18 - Trim Outboard Frameraill

- b) Grind this seam smooth and weld the 2 layers of sheet metal together.
- c) Place the jounce bumper bracket against the outer framerail and center it with the 7-1/4" centerline. The bracket should rest on the framerail seam that was just welded. Plug weld and perimeter weld the bracket to the framerail (Figure 19). Repeat this step for the opposite framerail.



Figure 19 - Weld Jounce Bumper Bracket

- d) Paint the framerails, framerail mount adapters, crush sleeves, and jounce bumper brackets. Re-install the Aluma-Frame cradle using the provided hardware. Torque the 7/16" hardware to 65 ft.-lbs. and the 1/2" hardware to 70 ft.-lbs.

8. Install lower control arm assemblies.

- a) Install the correct lower control arms (driver or passenger side) into the Aluma-Frame cradle. This is referenced by the bump stop pad being located on the forward tube of the control arm (Figure 20). A rubber mallet may be required to get the arms in position.



Figure 20 – Install Lower Control Arms

- b) Install the lower control arms using the provided 1/2"-13 x 3-3/4"L flange bolts and flange locknuts. The bump stop pad will be located on the front tube of the control arms. Install the front bolts from the rear with the locknuts located towards the front of the vehicle and install the rear bolts from the front with the locknuts located toward the rear of the vehicle. Torque to 65 ft.-lbs.

9. Final installation of the ALUMA-Frame and jounce bumpers.

- a) Install the jounce bumper spacer onto the jounce bumper and install it into the bracket. Verify that the jounce bumper will contact the bump stop pad on the lower control arms (Figure 21). Tighten the provided 5/16"-18 Nylock nut and washer. Repeat this step for the opposite side of the vehicle.

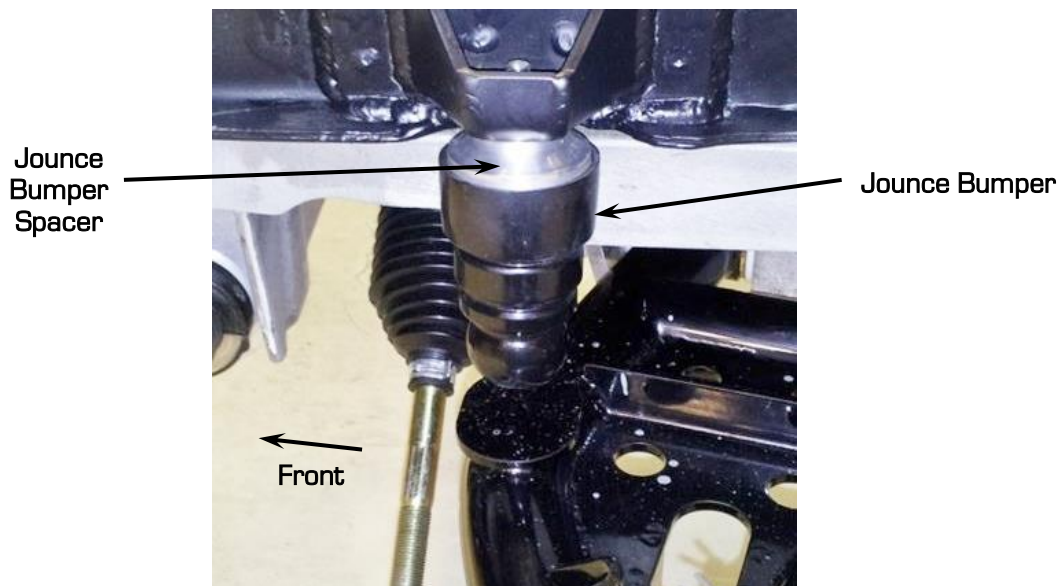

Figure 21 – Install Jounce Bumper

10. Install the anti-roll bar.

- a) Install the composite Delrin anti-roll bar bushings into the Aluma-Frame cradle on both sides (Figure 22). You will need to use a rubber hammer to fully seat the ARB bushings into the cradle. Before installing the ARB, use a spray lubricant or grease on the ID of the bushings. Do your best to fill the interior bushing grooves.



Figure 22 - Install ARB Bushings

- b) Install the ARB into the composite bushings. Center the ARB in the cradle, the bar should be protruding out from the bushings approximately 2-11/16" on each side (Figure 23).



Figure 23 - Center ARB

- c) Install the ARB split lock collars onto the ARB. Loosen both Allen screws in the lock collar and apply medium strength blue Loctite 242 to the threads. Position the collars up against the ARB bushings on each side. With the heads of the bolts accessible from the bottom, torque to 14 ft.-lbs. Make sure the groove in the collar is pointing towards the center of the frame and the size marking is to the outside (Figure 24 on the next page).

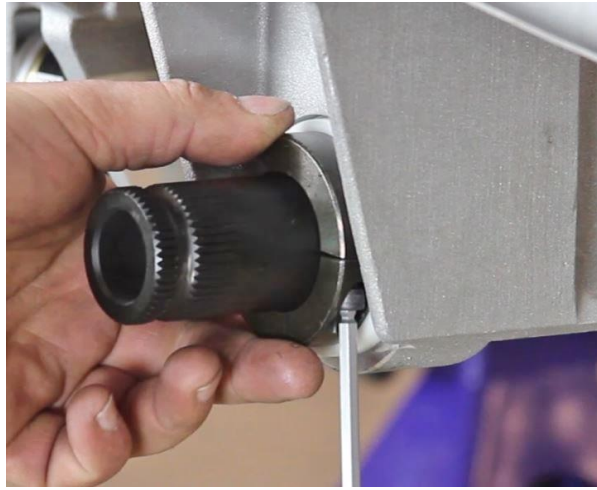

Figure 24 – Install Split Lock Collars

11. Install the upper control arm and coilover mount brackets.

- a) Place 2 of the upper control arm bracket shims on top of each framerrail adapter plate so that all the holes line up (Figure 25).

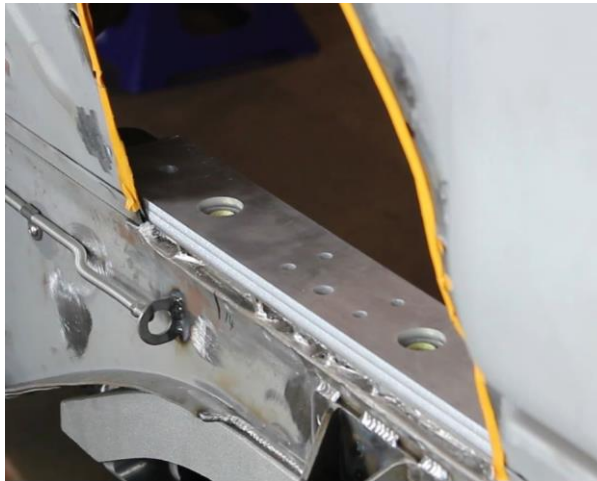

Figure 25 – Install UCA Bracket Shims

- b) Identify the left and right hand side upper control arm brackets. Install the Speed-*LIGN* adjusters in the front and rear mounting slots of the upper control arm brackets. The nominal caster setting is the “0” position on the adjusters located in the center groove on the Speed-*LIGN* frame (Figure 26). Install the 7/16”-14 x 2”L flange bolts with anti-seize on the threads, through the adjusters and into the adapter plates. Do not torque them down yet.



Figure 26 – Install Speed-*LIGN* Adjusters

- c) Place 2 of the coilover mount shims on each upper control arm bracket. Install the coilover mount brackets with the provided 5/16"-18 x 3-1/2"L flange bolts on each side of the framerail. The coilover mount ears are angled towards the front of the vehicle when installed (Figure 27). Repeat his step for the opposite side of the vehicle.

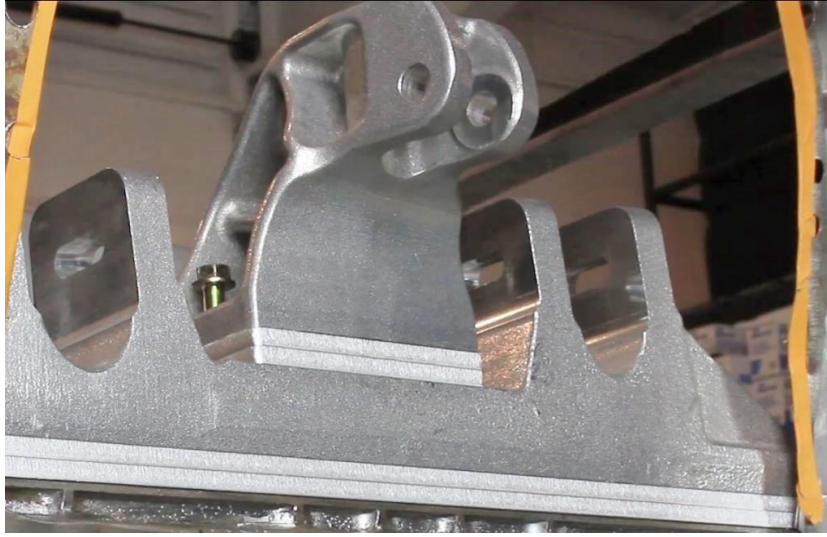

Figure 27 - Install Coilover Mount Shims

- d) Install the provided 7/16"-14 x 8-3/8"L flange bolts down through the top of the coilover mount on each side (Figure 28). Tighten down the 7/16" hardware.

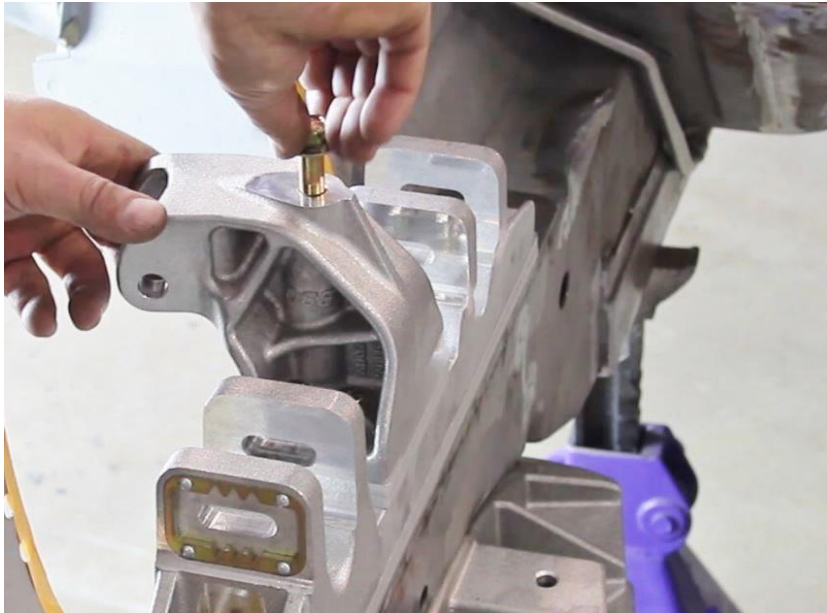

Figure 28 - Install Coilover Mount Brackets

- e) Torque the 7/16"-14 upper control arm mount bracket bolts to 50 ft.-lbs. Torque the 5/16"-18 coilover mount bolts to 25 ft.-lbs. and the 7/16"-14 coilover mount bolts to 65 ft.-lbs.

12. Install the upper control arm assemblies.

- a) Locate the left and right hand side upper control arm, they will be marked with an "L" for the driver's side and an "R" for the passenger side stamped on the top of the ball joint mounts for identification.

- b) Install the Speed-*LIGN* adjusters onto the 4 provided 7/16"-14 x 3-1/2"L flange bolts.
- c) Install the upper control arms; a rubber mallet may be required to get them in position.
- d) Install the hardware through the upper control arm brackets. The nominal caster setting of the adjuster is 1/8" inboard offset in the first outboard adjuster frame groove. Install the bolts with high strength red Loctite 262 and position the arms so that the adjuster is located in the nominal position (Figure 29).



Figure 29 – Install Upper Control Arms

- e) Install the 7/16"-14 flanged locknuts and torque to 35 ft.-lbs. Repeat this step for the opposite side of the vehicle.

13. Install each coilover assembly.

- a) Before installing each coilover, it is necessary to build each assembly.

For the *non-adjustable shocks*, please use the following steps to assemble each coilover shock:

- (1) Assemble the coilover shock by removing the snap ring using a set of snap ring pliers to remove the upper spring seat (Figure 30).
- (2) Once the upper spring seat is removed, the coilover adjuster nut must be threaded all the way to the bottom of the threads. Then you can install the Torrington bearing set (Figure 31) on each shock by installing one thrust washer, followed by the roller bearing and then another thrust washer. Detroit Speed recommends using high pressure grease between the roller bearing and thrust washers.



Figure 30 – Removing the Snap Ring



Figure 31 – Torrington Bearing Set

- (3) With the Torrington bearing set in place you can now install the coilover spring over the end of the shock.
- (4) With the coilover spring in place, install the upper spring seat along with the snap ring (Figure 32).



Figure 32 - Snap Ring Installed

For the *adjustable shocks*, please use the following steps to assemble each coilover shock:

- (1) Remove the upper spring seat from the retaining ring using a rubber hammer and moving it down off the upper shock mount (Figure 33).
- (2) Remove the retaining ring from upper shock mount and pass the upper spring seat over the upper shock mount (Figure 34).
- (3) Thread the spanner nut all the way to the bottom of the coilover shock and install the Torrington bearing set (Figure 31 on the previous page) on each shock by installing one thrust washer, followed by the roller bearing and then another thrust washer. Detroit Speed recommends using high pressure grease between the roller bearing and thrust washers.
- (4) Slide the coilover spring over the top of the upper shock mount.
- (5) Install the upper spring seat back over the top of the upper shock mount and re-install the retaining ring back onto the upper shock mount. Press the upper spring seat up onto the retaining ring so it locks in place.

The coilover assembly is now complete and ready to be installed.



Figure 33 - Remove Upper Spring Seat



Figure 34 - Upper Spring Seat & Retaining Ring

- b) Install the shock into the upper coilover mount with the shock body up and the shaft down. Install the tapered spacers on each side of the upper shock monoball and install the provided 1/2"-13 x 3"L flange bolt and flanged locknut using anti-seize on the threads (Figure 35). **NOTE:** If the shocks have a Schrader valve, face it outboard. If they have a remote canister orient the hose inboard.

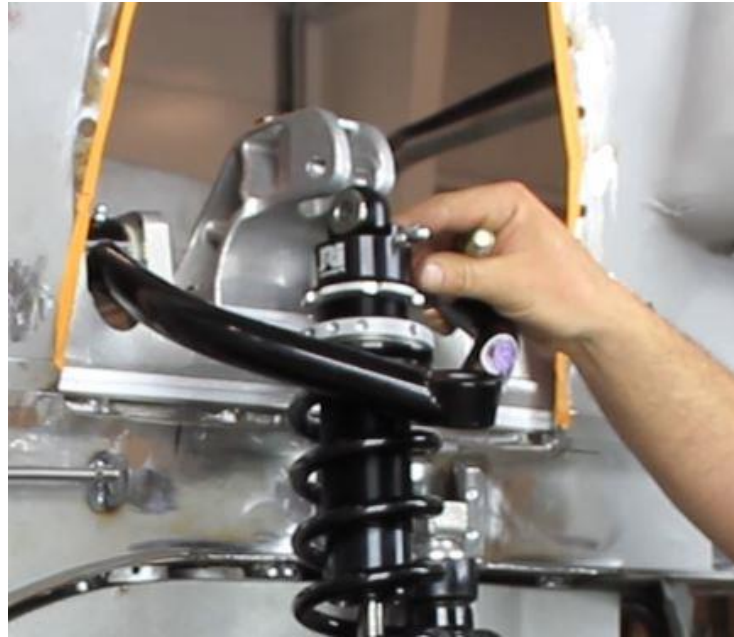

Figure 35 - Upper Coilover Mount

- c) Install the shock into the lower control arm using the provided 1/2"-20 x 2-1/2"L bolt and spacer through the lower monoball. Use anti-seize on the threads of the bolt and install the 1/2"-20 Nylock nut (Figure 36). Tighten the 1/2" hardware. Repeat this step for the opposite side.



Figure 36 - Lower Coilover Mount

- d) Torque the coilover shock bolts to 60 ft.-lbs.

NOTE: To install the Detroit Speed spindle assembly (castle nut used on upper ball joint), continue to Step 14. For the GM spindle assembly (Nut and washer used on upper ball joint), skip to Step 15.

14. Install the Detroit Speed spindle assembly.

- a) Clean any grease from the upper and lower ball joint studs and the spindle holes with a clean rag and lacquer thinner.
- b) Install the spindle assembly to the upper control arm first and then into the lower control arm (Figure 37). **NOTE:** Turn and position the studs so the cotter pins locates from front to rear to ease installation.



Figure 37 - Install Spindle Assembly

- c) Using high strength red Loctite 262, install the lower ball joint castle nut and torque to 20 ft.-lbs. plus an additional 180°. Install the cotter pin. **NOTE:** It is critical to follow the torque procedure listed in the table on page 5 and to use high strength red Loctite 262 on the lower ball joint threads.
- d) Install the upper ball joint castle nut and torque to 40 ft.-lbs., install the cotter pin. Repeat this step for the opposite side of the vehicle. Continue to Step 16.

15. Install the GM spindle assembly.

- a) Install the spindle to the upper control arm first.
- b) Torque the upper ball joint washer and nut.
- c) Place the spindle on the lower ball joint. **NOTE:** Turn and position the stud so the cotter pin locates from front to rear to ease installation.
- d) Tighten the lower ball joint nut to the appropriate torque setting and install the cotter pin. **NOTE:** It is critical to follow the torque procedure listed in the table on page 5 and to use high strength red Loctite 262 on the lower ball joint threads.
- e) Insert outer tie rod end into the steer arm and torque. Install the cotter pin.

16. Install the rack and pinion assembly.

- a) Before the rack and pinion is installed to the cradle, you can center the rack on the bench before it is installed. Mark a line along the length of the input shaft. Turn the rack all the way to one side and mark the housing where the line on the input shaft lines up. Turn the rack all the way in the other direction and count the turns in the opposite direction. Mark the housing where the line on the input shaft lines up. Turn the rack back in the opposite direction $1/2$ the amount of turns so that the line on the input shaft lands in between your 2 marks on the housing (Figure 38).



Figure 38 - Center the Rack & Pinion

- b) Install the rack and pinion mounting spacers into the counter bores of the cradle rack mounts (Figure 39).



Figure 39 - Install Mounting Spacers

- c) Install the provided $9/16$ "-18 x 4"L bolts and washers into the front side of the rack and pinion crush sleeves. Use anti-seize on the bolts and install the rack and pinion to the cradle with the $9/16$ "-18 flanged locknuts (Fig. 40). Torque the $9/16$ " bolts to 75 ft.-lbs.



Figure 40 - Installed Rack & Pinion

17. Install the outer tie rod ends.

- a) Install the grease fittings into the outer tie rod ends.
- b) Install the outer tie rod ends and jam nuts onto the rack and pinion, make sure they are equal distance on each side to center the steering. Measure the end of the threads to the edge of the jam nut, this measurement should be approximately 1" per side. Use anti-seize on the threads (Figure 41).



Figure 41 – Install Outer Tie Rods

- c) Install the outer tie rod into the steer arm. Install the castle nut and torque to 35 ft.-lbs. and install the cotter pin (Figure 42). Repeat this step for the opposite side of the vehicle.



Figure 42 – Install Tie Rod to Steer Arm

18. Pre-assemble the Anti-Roll Bar End Links to the Anti-Roll Bar Arms.

- a) Using anti-seize on the threads of the anti-roll bar endlinks, fully thread one end of the anti-roll bar endlinks into the threaded holes in each of the anti-roll bar arms (Figure 43).



Figure 43 – Pre-assemble ARB Endlinks

19. Install the Anti-Roll Bar Arms.

- a) Slide the ARB arm onto the splines of the anti-roll bar on either the driver or passenger side. Install the provided 3/8"-24 x 3"L bolt, nut and washer into the ARB arm with high strength red Loctite 262 and tighten (Figure 44).

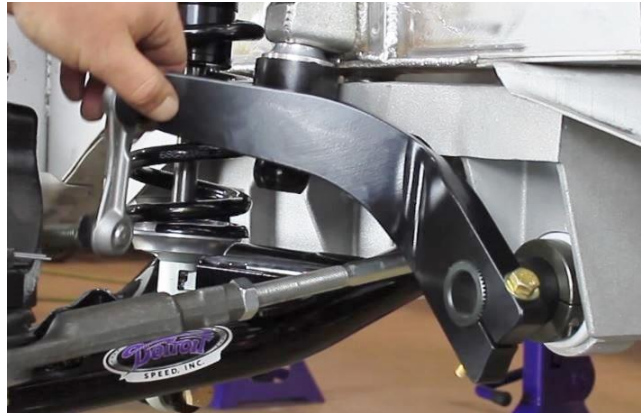

Figure 44 - Install ARB arms

- b) Insert the ARB endlink into the mounting bracket on the lower control arm. Tighten the endlink into the ARB arm with an 18mm wrench.
- c) Repeat this installation process for the opposite side of the vehicle. Make sure the ARB arms are timed properly so they are line up with each other on the ARB splines.
- d) With both sides installed, torque the anti-roll bar arm to anti-roll bar retaining bolts to 25 ft.-lbs. and the end link nuts to 45 ft.-lbs.

20. The suspension is assembled at this point. Figure 45 shows a completed installation.

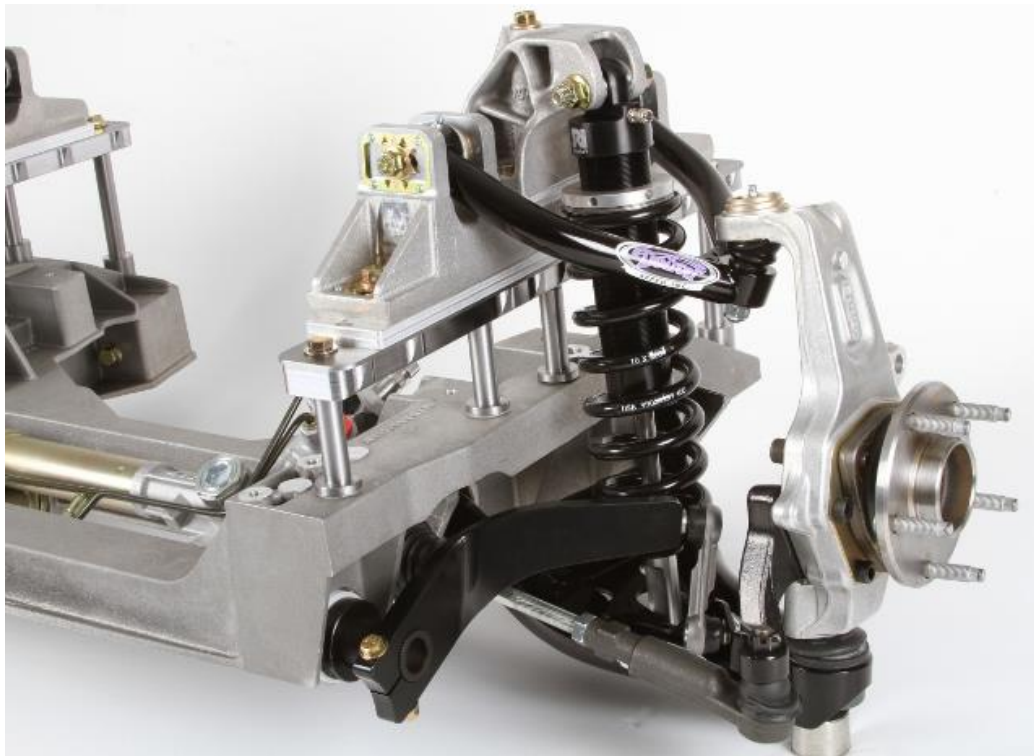

Figure 45 - Fully Assembled View (Driver side, Front)

21. After the ALUMA-Frame is installed into the vehicle, the power steering hoses can be attached to the steering gear. Follow Figure 46 for the location of the pressure and return ports.

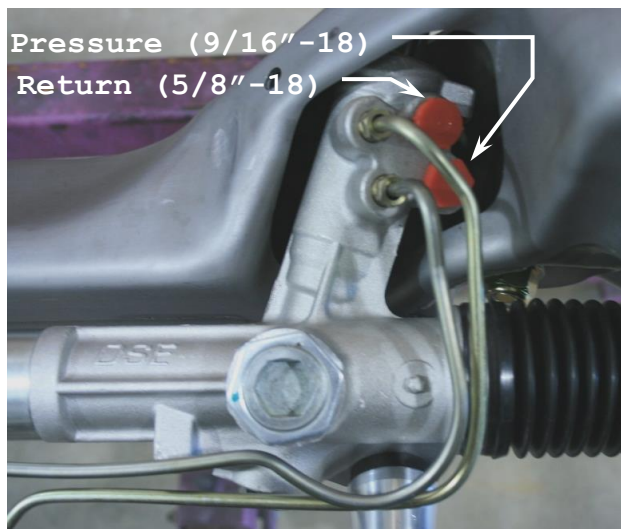

Figure 46 - Pressure and Return Port Locations

22. The front frame is now assembled and installed. **NOTE:** Be sure to lubricate all points on the front frame with quality chassis grease. Detroit Speed offers Driven Extreme Pressure chassis grease available as P/N: 140103 if needed.

23. Setting the vehicle ride height.

- a) With the vehicle assembled with all components installed, adjust the ride height as necessary. Detroit Speed does recommend using a small wipe of anti-seize before adjusting the spanner nut and compressing the coilover spring.
- b) Detroit Speed does include a Spanner Tool (P/N: 031060) to adjust ride height however if you have the adjustable coilover shocks, Detroit Speed does offer an Adjustment Tool available as P/N: 031061 if needed (Figure 47).



Figure 47 - Shock Adjustment Tools

24. If the Single Adjustable, Double Adjustable or the Double Adjustable Remote Canister Coilovers were purchased as an upgrade, refer to the following information for adjustment procedures.

Detroit Speed Single Adjustable Shock Applications

To change from the recommended “Detroit Tuned” valving, adjustments can be made independently to the rebound setting. The rebound is controlled by the knob at the lower shock mount (Shock is mounted body side up). The knob rotates clockwise (+) to increase the damping and counterclockwise (-) to decrease the damping. Refer to Figure 48a on the next page.



Figure 48a - Detroit Speed Single Adjustment Shock

To return to the Detroit Speed recommended settings, turn the knob clockwise (+) to full damping. Once at full damping, turn counterclockwise (-) to reach the recommended settings. Refer to Figure 48b for the recommended starting setting.

Rebound (Shaft Knob)..... 15 Open (counterclockwise, -)

Figure 48b - Detroit Speed Recommended Settings

Adjuster Operation

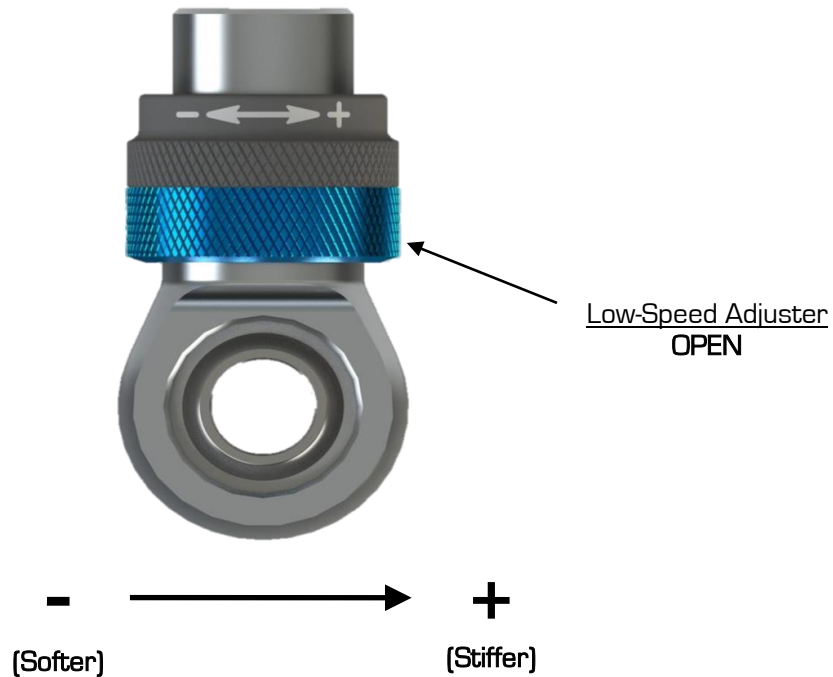

- **Adjuster (60-64 Clicks)**

The low-speed adjuster is a “clicker” style adjuster meaning that its adjustment is measured by detents located inside the blue adjuster knob. There are 16 clicks per 1 revolution of the knob. It uses a right-hand thread in its operation which means as you increase low-speed, the adjuster will move up on the eyelet. The recommended change for an adjustment is 8 clicks at a time. The low-speed adjuster’s reference position is **full stiff** (closed, or all the way up) and referred to -0 (-0 = full stiff, -64 = full soft).

- **Tuning Notes**
 - **Racetrack**
 - For more grip, soften the damping.
 - For increased platform control, stiffen the damping.
 - **Street**
 - For a more comfortable ride, soften the damping

***DO NOT FORCE KNOB WHEN IT STOPS TURNING, YOU MAY DAMAGE THE ADJUSTER AND INTERNAL HARDWARE**

Detroit Speed Double Adjustable Shock Applications

To change from the recommended “Detroit Tuned” valving, adjustments can be made independently to both the high and low speed settings. The rebound is controlled by the sweepers at the lower shock mount. The sweepers rotate clockwise (+) to increase the damping and counterclockwise (-) to decrease the damping. The sweepers can be seen in Figure 49a.



Figure 49a - Detroit Speed Double Adjustable Shocks

When adjusting the low speed rebound start at full (+) position, when adjusting the high speed rebound start at full (-) position. To return to the Detroit Speed recommended settings turn the sweeper clockwise (+) to full damping for the low speed setting, and counterclockwise (-) to full damping for the high speed setting. Once at full damping, turn counterclockwise (-) for the low speed setting, and clockwise (+) for the high speed setting to reach the recommended settings. Refer to Figure 49b for recommended settings.

- Low Speed Rebound [Sweeper]..... 20 sweeps [counterclockwise, -]
- High Speed Rebound [Sweeper]..... 2 sweeps [clockwise, +]

Figure 49b - Detroit Speed Recommended Settings

Detroit Speed Double Adjustable Shocks w/Remote Canisters

To change from the recommended “Detroit Tuned” valving, adjustments can be made independently to both the high and low speed settings. The rebound is controlled by the sweepers at the lower shock mount. The sweepers rotate clockwise (+) to increase the damping and counterclockwise (-) to decrease the damping. Refer to Figure 50a on the next page.

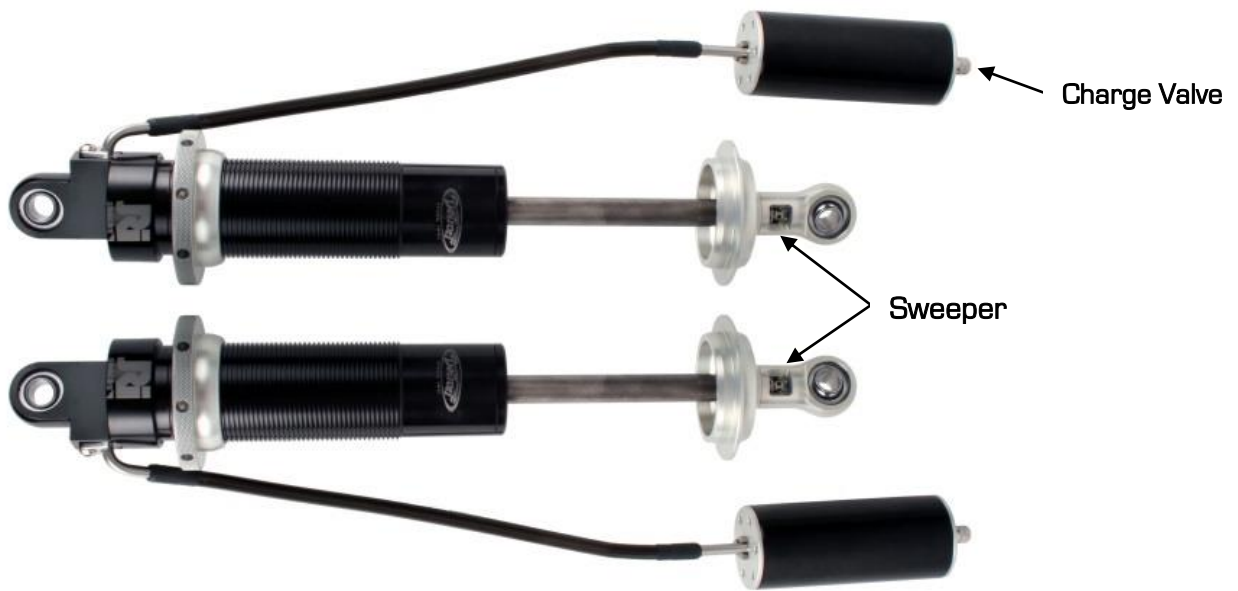

Figure 50a - Detroit Speed Double Adjustable Shock with Remote Canisters

When adjusting the low speed rebound start at full (+) position, when adjusting the high speed rebound start at full (-) position. To return to the Detroit Speed recommended settings turn the sweeper clockwise(+) to full damping for the low speed setting, and counterclockwise (-) to full damping for the high speed setting. Once at full damping, turn counterclockwise (-) for the low speed setting, and clockwise (+) for the high speed setting to reach the recommended settings. Refer to Figure 50b for recommended starting settings.

Low Speed Rebound [Sweeper]..... 20 sweeps (counterclockwise, -)
 High Speed Rebound [Sweeper]..... 2 sweeps (clockwise, +)

Figure 50b - Detroit Speed Recommended Settings

Adjuster Operation

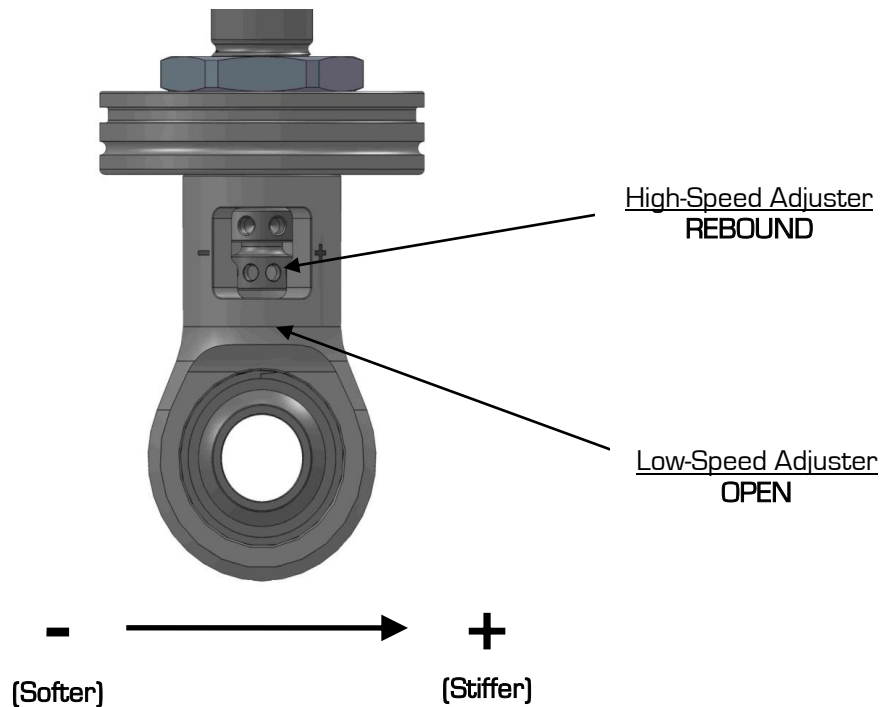

- **High-Speed Adjuster (12 Sweeps)**

The high-speed adjuster is a “sweep” style adjuster meaning that its adjustment is measured by the location of the adjuster in the eyelet window. It uses a left-hand thread in its operation which means; as you increase high-speed, the adjuster will move down in the window*. The high-speed adjuster’s reference position is **full soft** and referred to as +0 (+0 = full soft, +12 = full stiff).

- **Low-Speed Adjuster (25 Clicks)**

The low-speed adjuster is a “clicker” style adjuster meaning that its adjustment is measured by detent grooves located inside the high-speed shaft. It uses a right-hand thread in its operation which means; as you increase low-speed, the adjuster will move up in the window. The low-speed adjuster’s reference position is **full stiff** and referred to -0 (-0 = full stiff, -25 = full soft).

**The low-speed adjustment does not change when adjusting the high-speed.*

To aid in the installation of the reservoirs, we also offer a set of Billet Aluminum Remote Canister Mounts. The canister mounts are available exclusively through Detroit Speed, P/N: 032102 (Figure 51).



Figure 51 – Billet Aluminum Remote Canister Mounts

Detroit Speed Speed-LIGN Appendix

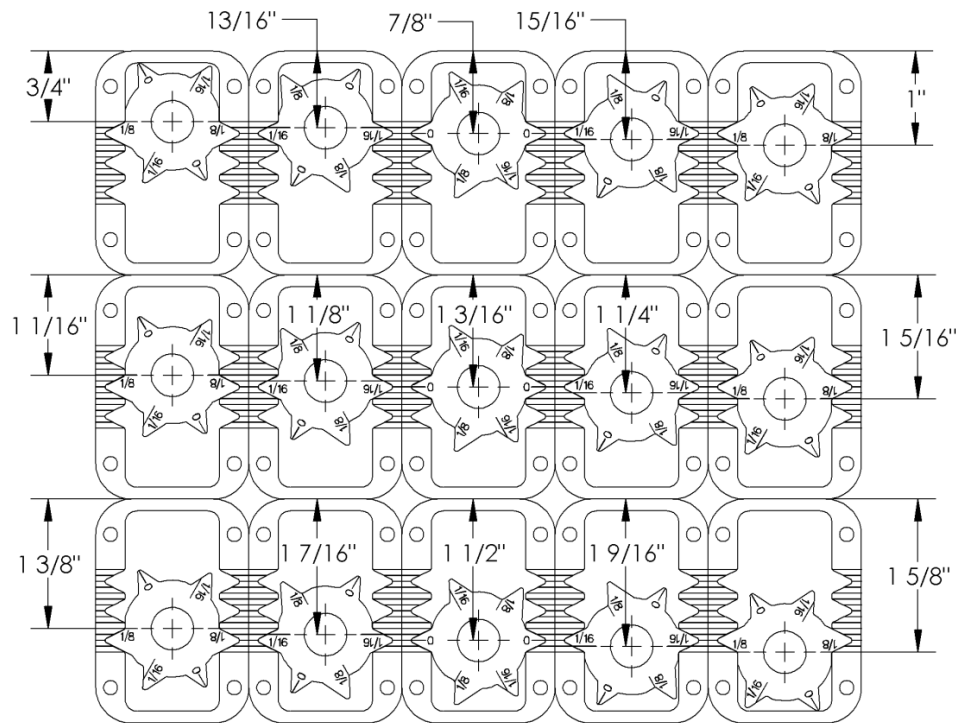
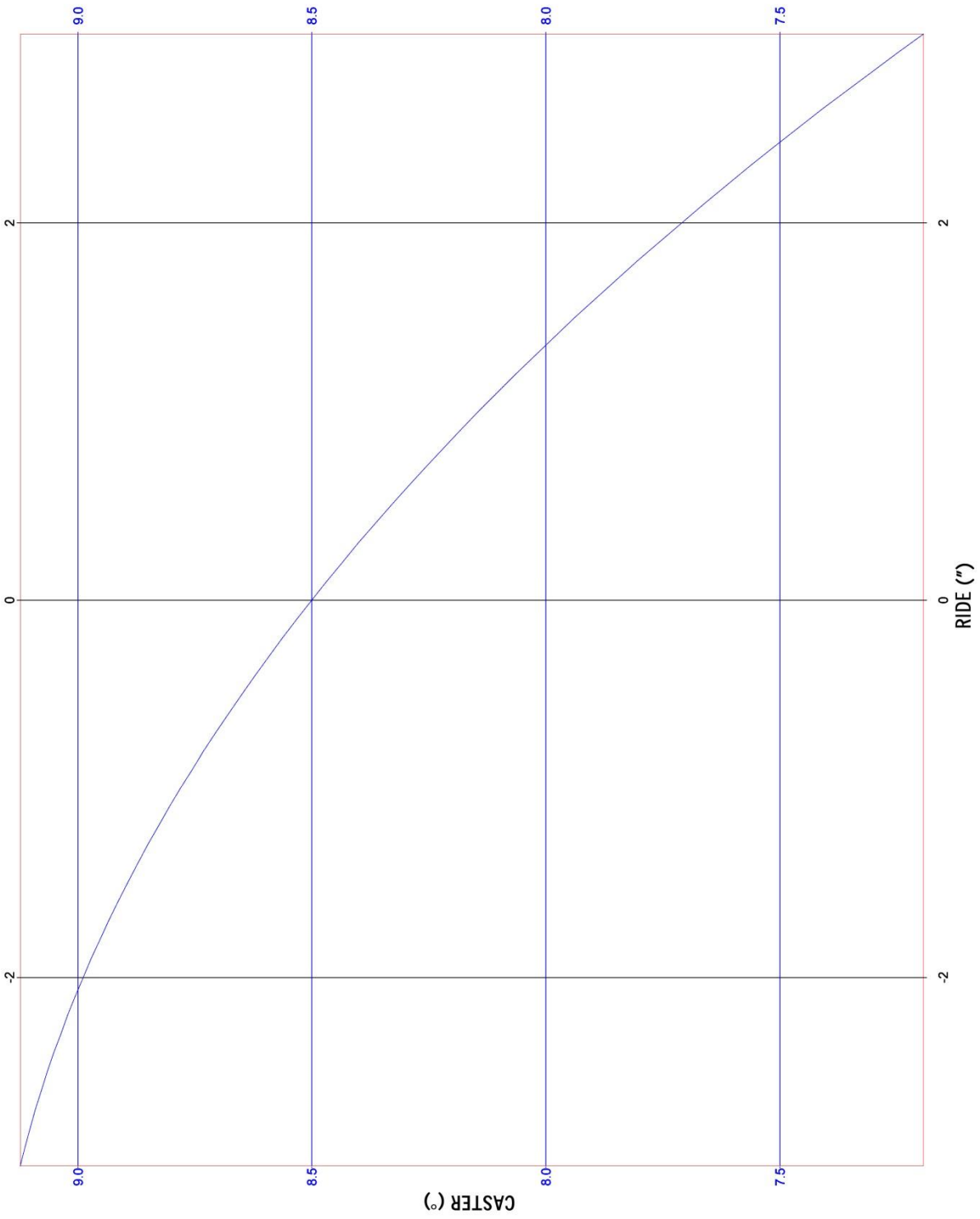
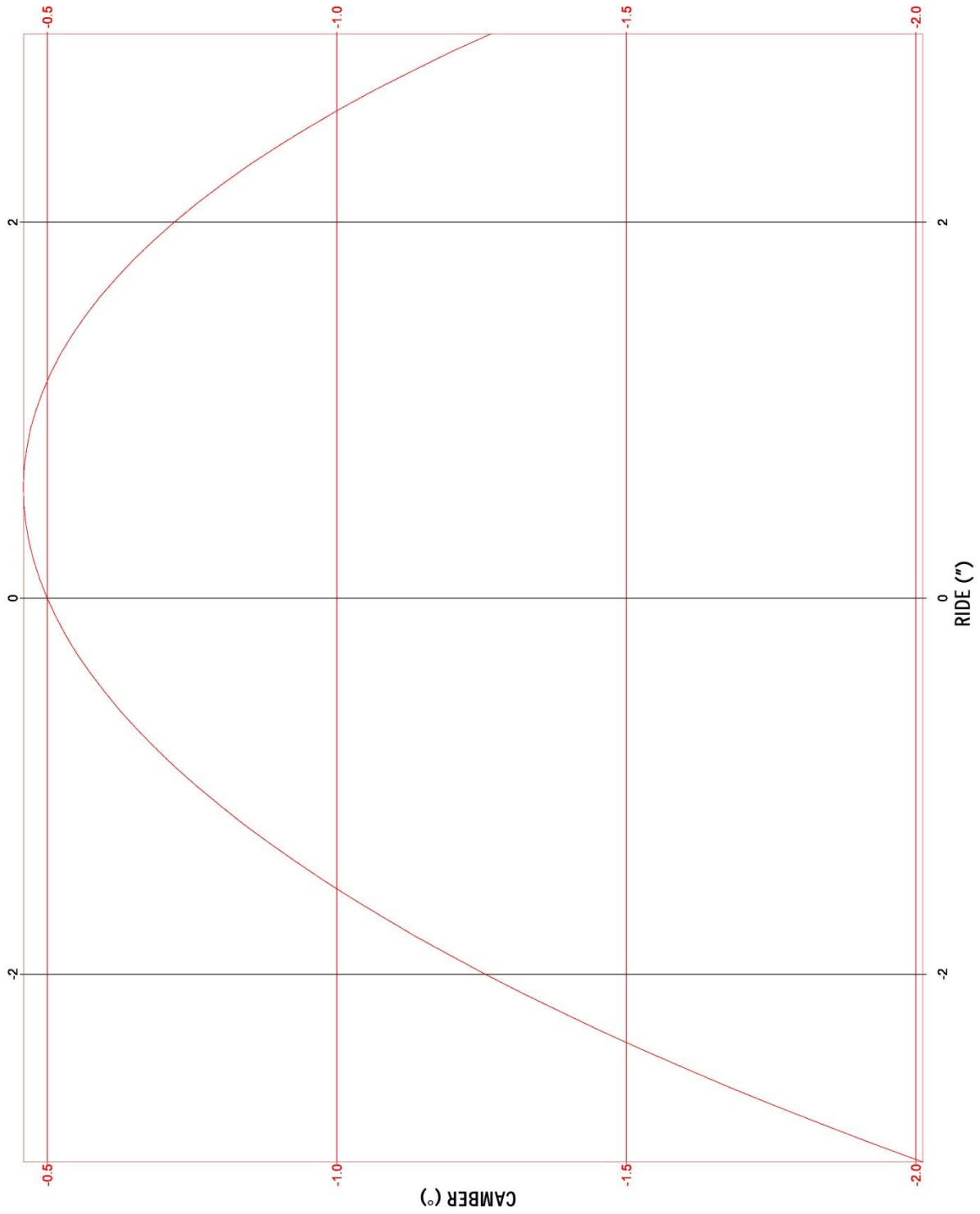

Figure 52 - Detroit Speed Speed-LIGN

The Detroit Speed patent pending Speed-LIGN adjustment device allows quick, accurate, and repeatable adjustments to be made without needing any additional components. The Speed-LIGN adjuster consists of a notched outer frame which is attached to a frame with a slotted adjustment hole and the Speed-LIGN adjuster which locates a bolted component. The Speed-LIGN adjuster can be rotated to achieve five settings in increments of $1/16"$ [$-1/8$, $-1/16$ ", 0 , $+1/16$ ", $+1/8$ "] for every notch in the outer frame. For example, a three notch adjuster would have fifteen settings $1/16"$ apart with a total of $7/8"$ of adjustment. Adjustments are simply made by loosening the attaching fastener enough so the Speed-LIGN adjuster can be released from the notched frame and then moved to the desired notch/position. Once the fastener is tightened, the Speed-LIGN adjuster locks the fastener in the desired position in the slot. The Speed-LIGN adjuster and the notched frame are clearly marked so that the adjuster position can be read and recorded.

25. Have a professional alignment completed following the specifications given in the chart on Pg. 2.





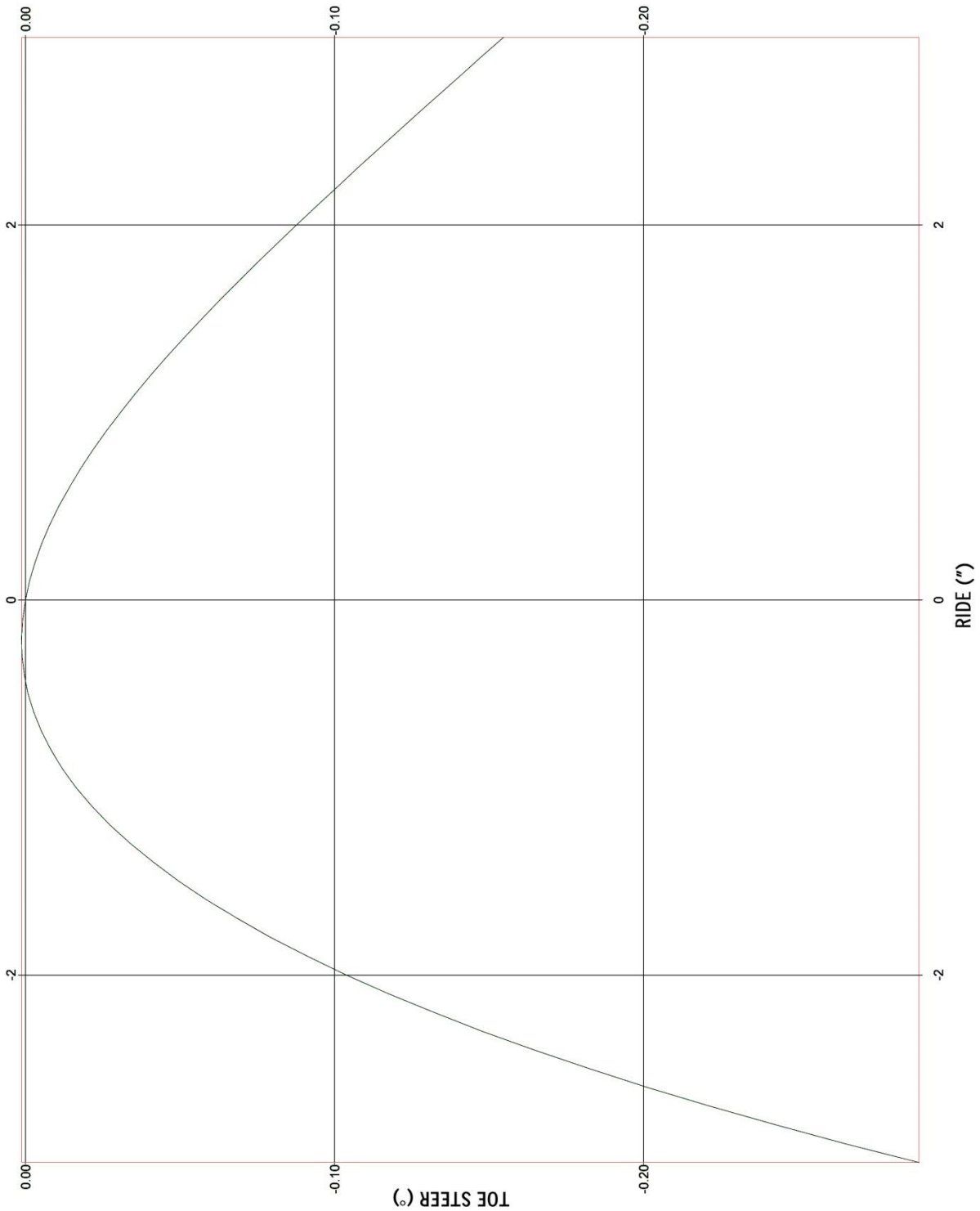

If you have any questions before or during the installation of this product please contact Detroit Speed at tech@detroitsspeed.com or 704.662.3272

Legal Disclaimer: *Detroit Speed, Inc. is not liable for personal, property, legal, or financial damages from the use or misuse of any product we sell. The purchaser is solely responsible for the safety and performance of these products. No warranty is expressed or implied.*

