

**READ ALL INSTRUCTIONS COMPLETELY AND THOROUGHLY UNDERSTAND THEM BEFORE DOING ANYTHING.
CALL TOTAL CONTROL PRODUCTS TECH SUPPORT (916) 388-0288 IF YOU NEED ASSISTANCE.**

INSTALLATION GUIDE



TCP STRD-05 Adjustable Strut Rods



Description: Direct replacement strut rods for use with OEM or TCP lower control arms.

Applications: Comet '60-65, Cyclone '64-65, Falcon '60-65, Mustang '64-66, Ranchero '60-65

Note: Must upgrade to V8 spindle

WARRANTY NOTICE:

There are NO WARRANTIES, either expressed or implied. Neither the seller nor manufacturer will be liable for any loss, damage or injury, direct or indirect, arising from the use or inability to determine the appropriate use of any products. Before any attempt at installation, all drawings and/or instruction sheets should be completely reviewed to determine the suitability of the product for its intended use. In this connection, the user assumes all responsibility and risk. We reserve the right to change specification without notice. Further, Chris Alston's Chassisworks, Inc., makes **NO GUARANTEE** in reference to any specific class legality of any component. **ALL PRODUCTS ARE INTENDED FOR RACING AND OFF-ROAD USE AND MAY NOT BE LEGALLY USED ON THE HIGHWAY.** The products offered for sale are true race-car components and, in all cases, require some fabrication skill. **NO PRODUCT OR SERVICE IS DESIGNED OR INTENDED TO PREVENT INJURY OR DEATH.**

Total Control Products
A Chris Alston's Chassisworks, Inc. Brand
8661 Younger Creek Drive
Sacramento, CA 95828
Phone: 916-388-0288
Technical Support: tcptech@cachassisworks.com



ITEM	QTY	PART NO.	DESCRIPTION
1	1	7906-041	STRUT ROD CONTROL ARM ADAPTER 01 WELDMENT, 2nd DESIGN
2	1	7906-042	STRUT ROD CONTROL ARM ADAPTER 02 WELDMENT, 2nd DESIGN
3	2	7906-061	PIVOT HOUSING ASSY, Ø1.35 MOUNT STRUT PIVOT, MUSTANG
4	1	7906-058	BACKUP NUT STRUT PIVOT, MUSTANG
5	1	3157-038S-S	WASHER, 3/8 SAE, STAINLESS, .812 OD x .406 ID x 1/16 THICK
6	1	3108-0381-S	INTERNAL TOOTH LOCK WASHER, 3/8 STAINLESS 410
7	1	3104-038F1.00C	BUTTON HEAD CAP SCREW, 3/8-24 x 1, CLEAR ZINC
8	1	3102-075-16RC	JAM NUT, 3/4-16 RIGHT, CLEAR ZINC
9	8	3120-044S-Y	FLAT WASHER, 7/16 SAE, HARDENED
10	4	3103-044C1.50C	SOCKET HEAD CAP SCREW, 7/16-14 x 1 1/2, CLEAR ZINC
11	4	3101-044-14C	LOCKNUT 7/16-14, GRADE 5 NYLON INSERT, CLEAR ZINC
12	10	3157-031S-C	WASHER, 5/16 SAE, ZINC PLATED, 11/32 ID x 7/8 OD x 1/16 THICK
13	2	3103-031C1.00C	SOCKET HEAD CAP SCREW, 5/16-18 x 1, CLEAR ZINC
14	2	3101-031-18C	LOCKNUT 5/16-18, GRADE 5, NYLON INSERT, CLEAR ZINC

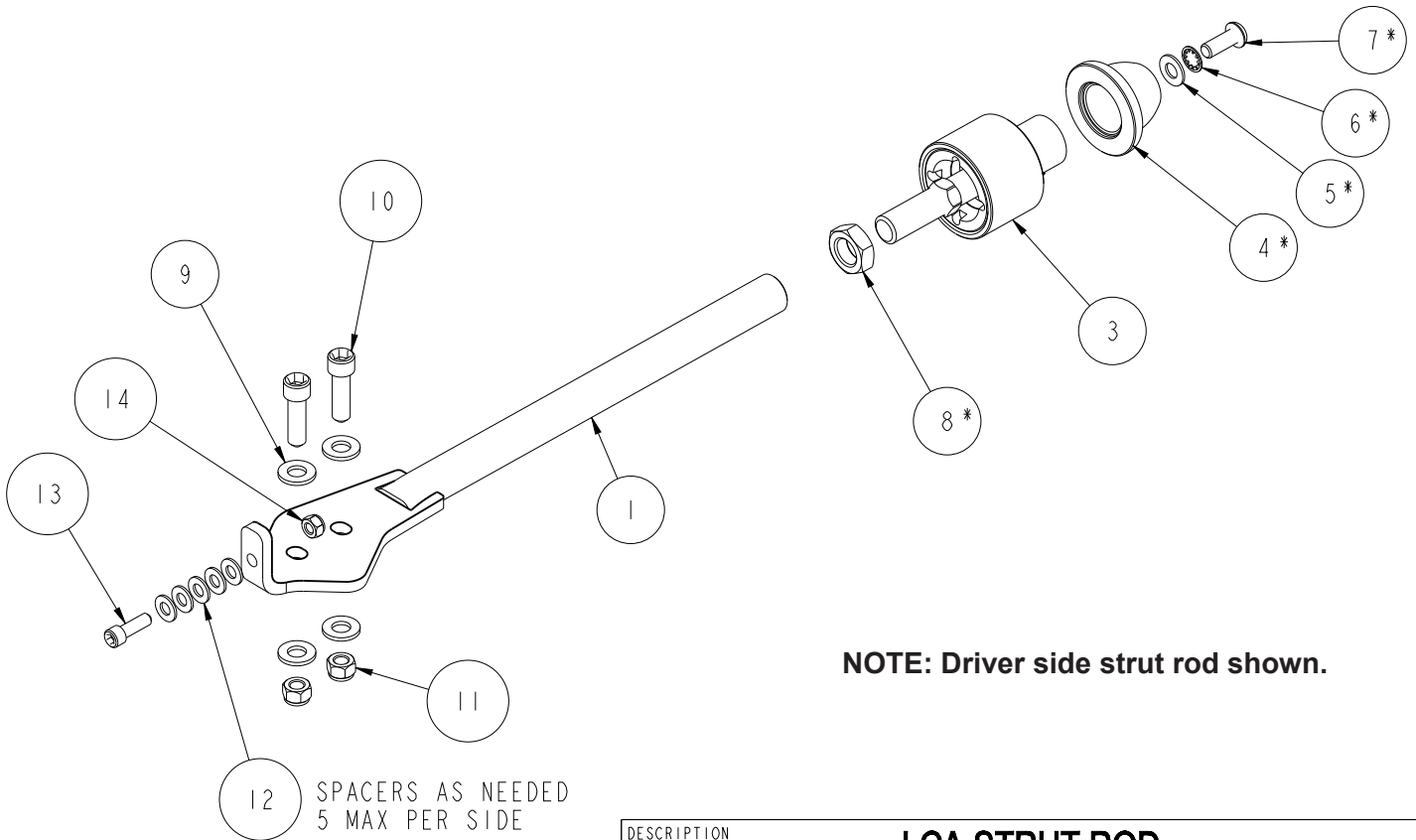

* PART OF 7906-061

DESCRIPTION		LCA STRUT ROD 17 15/16 INLINE	
Chris Alston's CHASSISWORKS INC. 8661 YOUNGER CREEK DRIVE SACRAMENTO, CA 95828 (916) 388-0288 FAX 388-0295		PART NO. TCP STRD-05	
		8/26/10	DWG: 7903-STRD-05

PARTS LIST

TCP STRD-05-SVH - Strut Rod 17- 15/16" OAL

Qty	Part Number	Description
1	7906-041-SVH	Strut rod weldment driver side
1	7906-042-SVH	Strut rod weldment passenger side
2	7906-061	Strut pivot mount 1.35" mount bore
1	7918-001	Hardware bag

7918-001 - Hardware Bag

Qty	Part Number	Description
2	3101-031-18C	Locknut 5/16-18 nylon insert
4	3101-044-14C	Locknut 7/16-14 nylon insert
2	3103-031C1.00C	Socket head 5/16-18 x 1" socket head cap screw
4	3103-044C1.50C	Socket head 7/16-14 x 1-1/2" socket head cap screw
8	3120-044S-Y	Washer 7/16" flat SAE, hardened
10	3157-031S-C	Washer 5/16" flat SAE

INSTRUCTIONS

Remove OEM Components

1. Raise front end of car and secure with jack stands.
2. Wheels must not be in contact with ground.
3. Remove wheels, making note of which side of vehicle they were removed from.
4. Remove the two bolts and nuts that attach the factory strut rod to the lower control arm.
5. Remove the large nut on the forward side of the strut-rod frame mount that retains the rubber bushing.
6. Remove the factory strut rod from vehicle.
7. Discard factory hardware and parts.



8. Remove the steel sleeve from the frame mount with a chisel.
9. With the strut rod out of the way, inspect sheet metal for signs of fatigue.

Clean the area to remove any grease or dirt so metal and welds are clearly visible. Look for cracks along welds and/or tearing of the mounts in any way. If there is any damage present, repairs must be made before proceeding.



10. Thread the 3/4-16 RH jam nut onto the stud of the pivot assembly 1-1/16”.

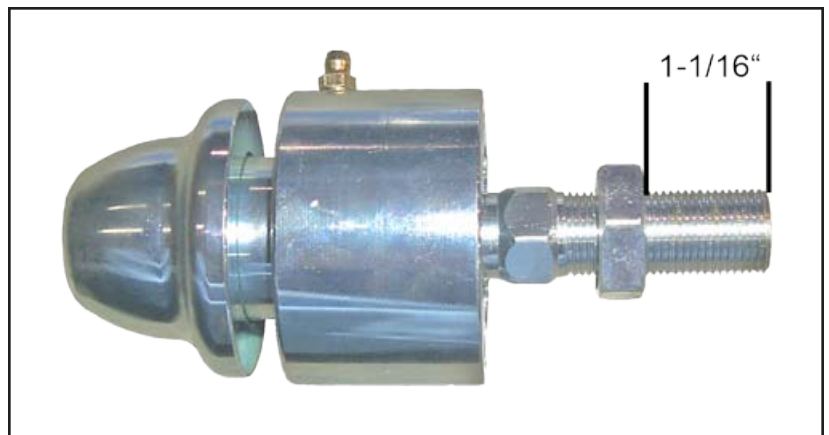

11. Apply anti-seize to threads on the pivot stud.



12. Screw pivot assembly into strut rod.



13. Remove button-head screw and backup nut from the pivot assembly.



14. Rest the strut rod plate on top of the lower control arm before inserting the pivot housing into the factory frame mount.
15. Rotate the pivot housing so that the zerk fitting is pointing down and can be easily accessed with a grease gun.
16. Apply anti-seize onto the threads and the screw the backup nut onto the pivot housing.

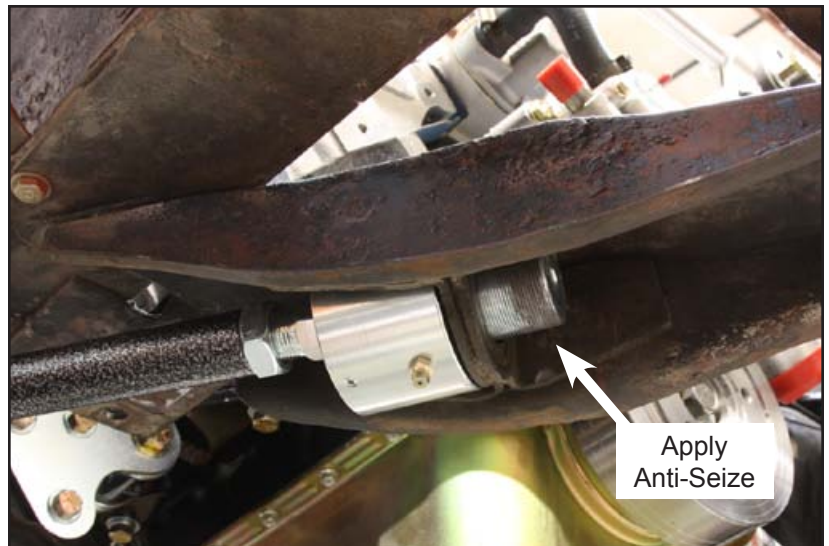

17. Tighten the backup nut using a 1/2"-drive ratchet; torque to 150 lb-ft.

Do not use an impact gun .



18. Apply Loctite™ threadlocker to the 3/8” button-head screw, and then install with a flat washer and lock washer.

19. Tighten the button head to 30 lb-ft.



20. Loosely bolt the strut-rod plate to the lower control arm using hardware shown.

21. The adapter plate steering stop must be pointing up.



22. Using the pivot stud hex, adjust the length of strut rod to position lower control arm square to frame rail.



23. Once adjustment is complete, tighten the jam nut against the strut rod. Hold the pivot stud hex with a wrench to prevent from adjusting the strut rod length.



24. Tighten the socket-head cap screws to 60 lb-ft.
25. Grease the pivot assemblies using a standard grease gun.



Steering Stop Installation

Due to variations in chassis and common spindle swaps we have included an adjustable hardware stop to limit steering travel, preventing the tie-rod assemblies from contacting the rack body..

26. With the suspension at ride height turn the steering to full lock.
27. Measure the distance from the strut-rod tab to the flat contact area of the steering arm.
28. Place as many flat washers as needed onto the bolt to be slightly thicker than the measured distance (including the socket head of the bolt).



29. Thread the locknut onto the bolt and tighten to 25 lb-ft.
30. With the steering at full lock, verify there is clearance between all components as the suspension is moved throughout its range of travel. Add washers to the stop, if needed.
31. Install wheels to their original position and torque lug nuts.



Torque Specifications

Fastener Description	Location	Torque Value
Backup Nut, 1/2 drive (Item 3)	Strut Rod Frame Mount	150 ft lbs
Button Head Cap Screw, 3/8-24 x 1	Backup Nut (Jam Bolt)	30 ft lbs
Jam Nut, 3/4-16	Pivot Assembly to Strut Rod	80 ft lbs
Hex Head Cap Screw, 7/16-14 x 1-1/2	Strut Rod Adapter Plate to Lower Control Arm	60 ft lbs

Alignment

The vehicle must be professionally inspected and aligned prior to regular use.

If a trailer is not available, your alignment will need to be somewhat close to final specs in order to safely drive your vehicle to the alignment shop. Visually determine if the front wheels look straight. They should not appear to “toe” (left to right) -in or -out. The outside of the wheels should be very close to vertical. A few degrees of negative camber (leaning in) is acceptable.

	Street Performance		Road Course		Drag Strip	
	Manual	Power	Manual	Power	Manual	Power
Caster	2-1/2° to 3° pos.	3-1/2° to 4° pos.	2-1/2° to 3° pos	3-1/2° to 4° pos	4° to 6° pos	4° to 6° pos
Camber	0° to 1/2° neg	0° to 1/2° neg	1-1/2° to 2° neg	1-1/2° to 2° neg	0°	0°
Toe (total)	1/16” to 1/8” in	1/16” to 1/8” in	1/16” out to 1/16” in	1/16” out to 1/16” in	1/16” to 1/8” in	1/16” to 1/8” in

Our recommended alignment specs serve as a starting point for your particular application. Installed components, driver preference, and specific application will have a great affect on the correct settings for your vehicle.