

**READ ALL INSTRUCTIONS COMPLETELY AND THOROUGHLY UNDERSTAND THEM BEFORE DOING ANYTHING.
CALL TOTAL CONTROL PRODUCTS TECH SUPPORT (916) 388-0288 IF YOU NEED ASSISTANCE.**

INSTALLATION GUIDE



TCP UCA-07 Coil-Spring Upper Control Arm with Dropped Pivot Shaft 1967-73 Mustang



Description: Adjustable length upper control arm for 4.75" bolt pattern with offset pivot shaft for camber gain improvement. For use with OEM replacement spring perch.

Applications: Comet '66-77, Cougar '67-73, Cyclone '66-71, Fairlane '66-71, Falcon '66-70, Maverick '70-77, Montego '68-71, Mustang '67-73, Ranchero '66-71, Torino '68-71

IMPORTANT: The outer shock tower reinforcement plate and suspension bump stop must be reinstalled prior to operating the vehicle. Worn or damaged suspension bump stops must be replaced. Failure to provide a proper compression-travel suspension stop will cause unwarrantable damage to the shock absorber and possible structural damage to the chassis.

THIS DRAWING CONTAINS PROPRIETARY INFORMATION OF CHRIS ALSTON'S CHASSISWORKS, INC. AND SHALL NOT BE REPRODUCED, TRANSFERRED TO OTHER DOCUMENTS, DISCLOSED TO OTHERS, USED FOR MANUFACTURING, OR FOR ANY OTHER PURPOSE, IN WHOLE OR IN PART WITHOUT PRIOR WRITTEN PERMISSION OF CHRIS ALSTON'S CHASSISWORKS, INC.

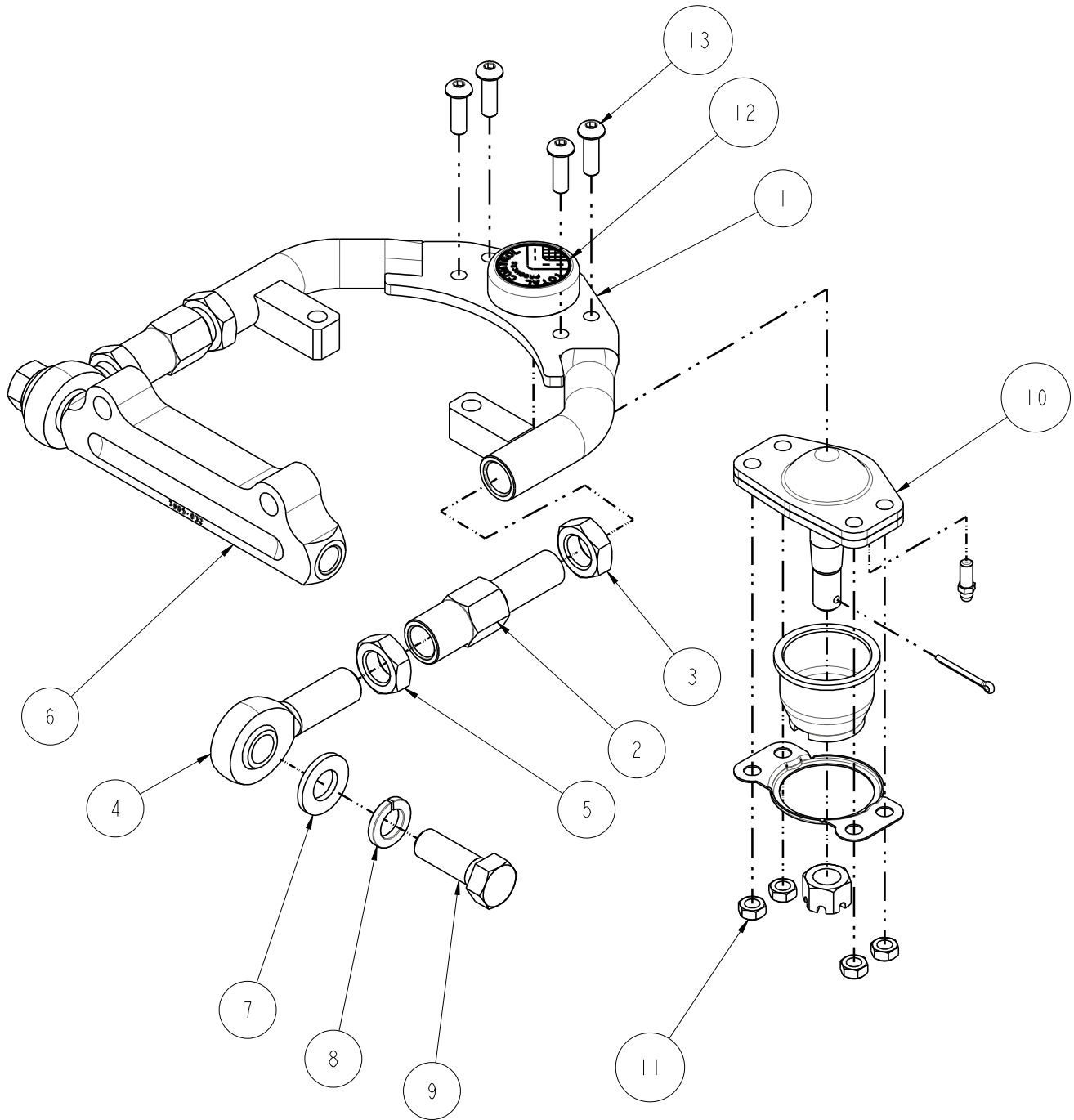

DISCARD SCREW, NUT AND LOCK WASHER INCLUDED WITH BALLJOINT

REVISIONS				
ZONE	REV	DESCRIPTION	DATE	APPROVED
	1	CHANGE BALLJOINT SCREW AND NUT	11/23/07	S. RIEGER

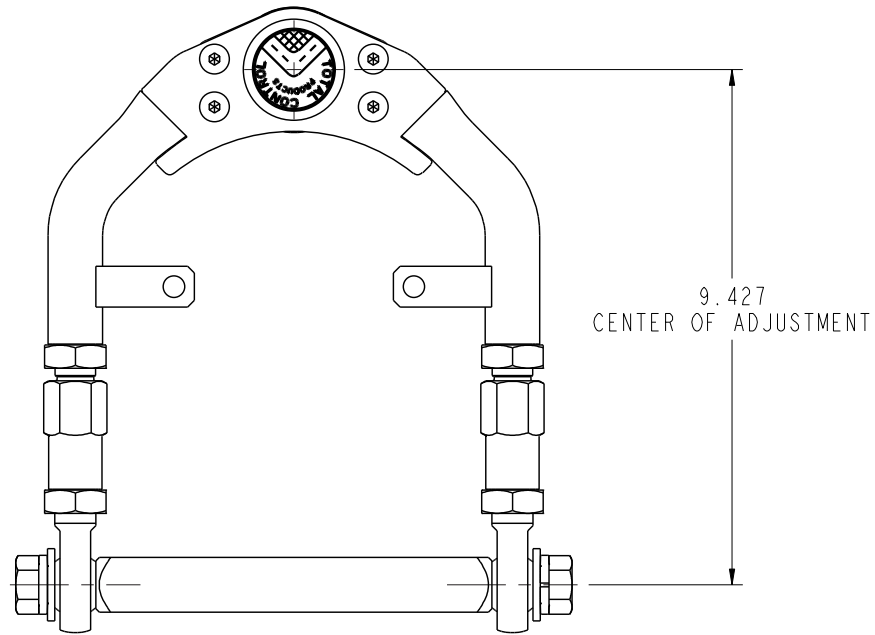

ITEM	QTY	PART NO.	DESCRIPTION
1	1	7905-015	UPPER ARM WELDMENT, TABS, TCP
2	2	7905-003	ADJUSTMENT COUPLER 3/4-16 RIGHT & LEFT
3	2	3102-075-16LY	JAM NUT, 3/4-16 LEFT, YELLOW ZINC
4	2	3112-075X063-R	ROD END 3/4 x 5/8 BORE, 4130 RIGHT, NYLON KMX12-10
5	2	3102-075-16RC	JAM NUT, 3/4-16 RIGHT, CLEAR ZINC
6	1	7905-032	PIVOT SHAFT, DROPPED 1", 4.75 SPACING, UPPER CONTROL ARM
7	2	3120-063S-Y	FLAT WASHER, 5/8 SAE, HARDENED
8	2	3108-063L-C	LOCK WASHER Ø5/8, SPRING
9	2	3100-063FI.75Y	BOLT, 5/8-18 x 1 3/4 HEX HEAD, GRADE 8
10	1	7905-023	BALL-JOINT KIT W/HARDWARE 4-BOLT STYLE 1964/1970 MUSTANG
11	4	3129-031-18C	5/16-18 HEX TOP LOCK NUT GRADE C (5) CLEAR ZINC
12	1	7903-DECAL-RI.5	DECAL, ROUND Ø1 1/2, TOTAL CONTROL PRODUCTS
13	4	3104-031CI.00C	BUTTON HEAD SOCKET CAP SCREW 5/16-18 x 1, CLEAR ZINC

UNLESS OTHERWISE SPECIFIED DIMENSIONS ARE IN INCHES FRACTIONS TOLERANCES ±1/16 ±.05 ANGLES ±.01 DECIMAL ±.005 ±.0010	APPROVALS DRAWN BY: S. RIEGER CHECKED BY: S. RIEGER DWG RELEASE LEVEL: Released	DATE 9/21/07 11/7/07	DESCRIPTION A-ARM ASSEMBLY, UPPER, WITH TABS, 4.75 DROPPED MNT, MUSTANG Chris Alston's CHASSISWORKS INC. 8661 YOUNGER CREEK DRIVE SACRAMENTO, CA 95828 (916) 388-0288 FAX 388-0295
FINISH NONE MATERIAL ASSEMBLY	SIZE B	PART NO. 7905-037	PART REV. 1
SCALE: 5:16		DWG: 7905-037 REV: 1	
SHEET 1 OF 1			

PARTS LIST

TCP UCA-07 - Coil-Spring Upper Control Arms, 4.75" Bolt Pattern

Qty	Part Number	Description
2	7905-027	UCA shim .10 x 4.75 spacing
2	7905-037	UCA assembly 4.75" with tabs, dropped shaft
1	7918-021	Hardware bag

7905-037 - Upper Control Arm Assembly

Qty	Part Number	Description
2	3100-063F1.75Y	Bolt 5/8-18 x 1-3/4" hex head cap screw
2	3102-075-16LY	Jam nut 3/4-16 LH, 1-1/8" hex x .42" tall
2	3102-075-16RC	Jam nut 3/4-16 RH, 1-1/8" hex x .42" tall
4	3104-031C1.00C	Button head 5/16-18 x 1" cap screw
2	3108-063L-C	Lock washer 5/8" regular
2	3112-075X063-R	Rod end RH 3/4"-thread x 5/8"-bore
2	3120-063S-Y	Washer 5/8" flat SAE, hardened
4	3129-031-18C	Top lock nut 5/16-18 all steel
2	7905-003	Coupler male-female 3/4-16 x 3/4-16 x 3-3/4" length
1	7905-015	Upper arm weldment with tabs
1	7905-023	Upper balljoint, 4-bolt
1	7905-032	Dropped pivot shaft, 1/2" holes, 4.75 apart

7918-021 - Hardware Bag

Qty	Part Number	Description
4	3100-038C1.75Y	Bolt 3/8-16 x 1-3/4" hex head cap screw
4	3100-050C2.50Y	Bolt 1/2-13 x 2-1/2" hex head cap screw
4	3101-038-16C	Locknut 3/8-16 nylon insert 9/16" hex x .45" tall
4	3108-050L-C	Lock washer 1/2" regular
8	3120-038S-Y	Washer 3/8 flat SAE, hardened
8	3120-050S-Y	Washer 1/2" flat SAE, hardened
4	3230	Nut 1/2-13 standard 3/4" hex x .44" Tall

INSTRUCTIONS

1. Raise front end of car and secure with jack stands. Wheels must not be in contact with ground.
2. Remove wheels, making note of which side of vehicle they were removed from.
3. Unbolt lower shock mount from spring perch (Figure 5-1).
4. Unbolt upper shock mount from shock tower (Figure 5-2).
If replacing the shock, unbolt shock from upper mount prior to unbolting mount.
5. Remove shock and mount from vehicle (Figure 5-3).



Figure 5-1



Figure 5-2



Figure 5-3

6. Using a spring compressor, remove the coil spring. Follow the tool manufacturer's instructions for proper use of the spring compressor.
7. Unbolt lower spring perch from control arm.
8. Secure lower control arm and spindle assembly. Place a jack stand under lower control arm. Keep spindle assembly in upright position to prevent damage to brake lines. Heavy wire or tie down straps can be used.
9. Remove cotter pin from upper balljoint.
10. Remove upper balljoint castle nut.
11. Using a pickle fork, separate upper balljoint from spindle. A large hammer can also be used to strike upright near balljoint. The jarring force will unseat the balljoint stud.
12. Remove upper arm pivot shaft nuts from engine side of shock tower, and remove upper arm.

13. Correctly orient control arm assembly for installation. The balljoint stud must point down and raised pivot shaft humps must point up, as shown on page 2.
14. Place a single 1/2" flat washer over each 1/2" mounting bolt.
15. Raise control arm into its mounting position, insert two bolts through the pivot shaft, and then through the shock tower mounting holes.
16. Secure bolts on engine side of shock tower using 1/2" flat washers, lock washers, and hex nuts. Torque hardware to 95 lb.ft.
Optional Use: Mounting shim (7905-027) is only needed to compensate for variances in shock tower alignment. It may be necessary to use both on one side or none.
17. Install spring perch onto control arm mounting tabs.
Torque hardware to 25-35 lb.ft.
18. Place upper balljoint stud into spindle upright tapered seat and install castle nut.
Torque to 75-80 lb. ft.
19. Install cotter pin, and then bend ends in opposite directions so that they wrap around the stud.
20. Check all mounting hardware.
21. Using a spring compressor, reinstall coil spring. Follow tool manufacturer's instructions for proper use of spring compressor.
22. Make sure spring is correctly positioned at upper and lower spring seats.
23. Install shock and upper shock mount. Torque upper and lower mount hardware to 22-34 lb.ft.
24. Balljoints can now be lubricated using standard grease gun.
25. Install wheels to their original position and torque lug nuts.
26. Lower vehicle.

Alignment

The vehicle must be professionally inspected and aligned prior to regular use.

If a trailer is not available, your alignment will need to be somewhat close to final specs in order to safely drive your vehicle to the alignment shop. Visually determine if the front wheels look straight. They should not appear to “toe” (left to right) -in or -out. The outside of the wheels should be very close to vertical. A few degrees of negative camber (leaning in) is acceptable.

Our recommended alignment specs serve as a starting point for your particular application. Installed components, driver preference, and specific application will have a great affect on the correct settings for your vehicle.

	Street Performance		Road Course		Drag Strip	
	Manual	Power	Manual	Power	Manual	Power
Caster	2-1/2° to 3° pos.	3-1/2° to 4° pos.	2-1/2° to 3° pos	3-1/2° to 4° pos	4° to 6° pos	4° to 6° pos
Camber	0° to 1/2° neg	0° to 1/2° neg	1-1/2° to 2° neg	1-1/2° to 2° neg	0°	0°
Toe (total)	1/16” to 1/8” in	1/16” to 1/8” in	1/16” out to 1/16” in	1/16” out to 1/16” in	1/16” to 1/8” in	1/16” to 1/8” in

Adjusting the Arm

- Loosen jam nuts to allow adjustment of the couplers.
- A thread lubricant is recommended to make adjusting easier and to prevent damage to threads.
- Both Caster and Camber adjustments can be made at upper arm.
- Turning adjustment couplers in same direction equal amounts will adjust camber.
- Turning adjustment couplers in opposite direction equal amounts will adjust caster.

Shortest adjustment length is achieved with the rod end and adjustment coupler threaded completely into their female counterparts.

Center of adjustment is four complete turns of the adjustment coupler from the shortest adjustment length. With the jam nuts threaded to the base of the male threads, there should be four threads visible at each end.

Longest adjustment length is four complete turns of the adjustment coupler from center of adjustment travel. With the jam nuts threaded to the base of the male threads, there should be eight threads visible at each end. If longer adjusted length is needed, use shim/s (7905-027) between pivot shaft and shock tower. *Minimum thread engagement is 3/4”.*

Center of Adjustment Dimensions

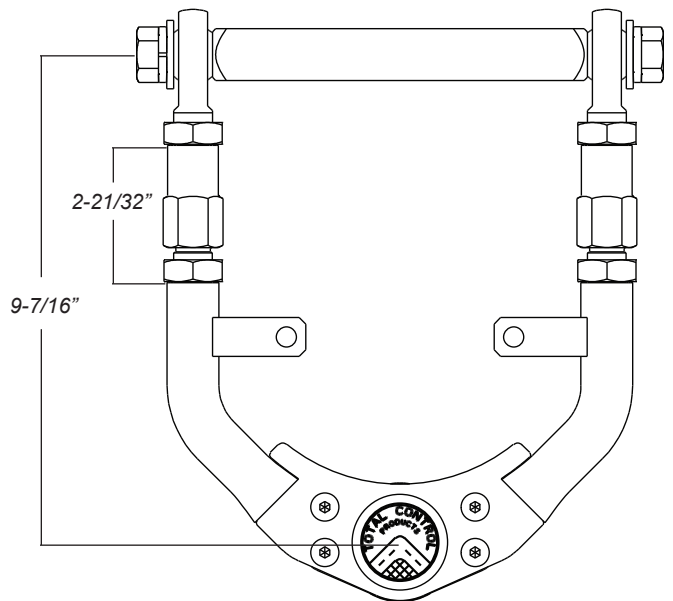

Adjustment range is + or - four threads.

WARRANTY NOTICE:

There are NO WARRANTIES, either expressed or implied. Neither the seller nor manufacturer will be liable for any loss, damage or injury, direct or indirect, arising from the use or inability to determine the appropriate use of any products. Before any attempt at installation, all drawings and/or instruction sheets should be completely reviewed to determine the suitability of the product for its intended use. In this connection, the user assumes all responsibility and risk. We reserve the right to change specification without notice. Further, Chris Alston's Chassisworks, Inc., makes **NO GUARANTEE** in reference to any specific class legality of any component. **ALL PRODUCTS ARE INTENDED FOR RACING AND OFF-ROAD USE AND MAY NOT BE LEGALLY USED ON THE HIGHWAY.** The products offered for sale are true race-car components and, in all cases, require some fabrication skill. **NO PRODUCT OR SERVICE IS DESIGNED OR INTENDED TO PREVENT INJURY OR DEATH.**

Total Control Products
A Chris Alston's Chassisworks, Inc. Brand
8661 Younger Creek Drive
Sacramento, CA 95828
Phone: 916-388-0288
Technical Support: tcptech@cachassisworks.com

