

Twisted Wedge[®] 11R Aluminum Cylinder Heads for the Small Block Ford

Thank you for purchasing Trick Flow Twisted Wedge 11R aluminum cylinder heads designed for the Small Block Ford.

Please follow the steps outlined in this instruction manual to ensure that the installation of your new cylinder heads is done correctly and that they perform according to design.

Please read all of the enclosed information before beginning any work. If you have any questions regarding installation or the written materials supplied with your new heads, contact the Trick Flow technical department at 1-330-630-1555 for assistance, Monday through Friday from 9:00 am to 5:00 pm ET.

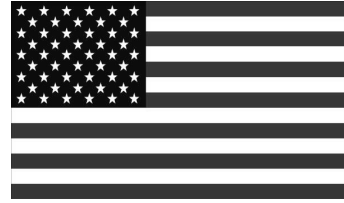

MADE IN U.S.A.

Project Overview

- Review all paperwork included in the installation packet
- Inspect the condition of all components
- Verify the part numbers and quantities of each product received (see Parts Checklist below)
- Mail the warranty card to Trick Flow
- Locate recommended tools
- Purchase any additional parts needed (See the Additional Parts Required section. Do not purchase pushrods until the proper length has been determined)
- Remove existing cylinder heads
- Clean and inspect the engine block
- Check header fitment
- Install new cylinder head locating dowels
- Modify water transfer holes (351 SVO and all pre-1972 blocks)
- Verify the head bolt size for your application
- Check piston to valve clearance
- Check pushrod length
- Purchase the appropriate length pushrods
- Install the new cylinder heads
- Adjust the valvetrain
- Make tuning adjustments
- Perform a proper break-in
- Test drive and enjoy!

Parts Checklist

You should have received the parts listed here. Please verify the part numbers and quantities of each component received.

- (1) Assembled cylinder head
- (1) Instruction packet
- (4) Guideplates
- (8) Rocker studs
- (1) 5/8"-11 threaded inserts (Twisted Wedge street heads)

If you are missing an item or a part was received in error, please contact Trick Flow at 1-330-630-1555, Monday through Friday from 9:00 am to 5:00 pm ET.

Recommended Tools

- Shop Manual for your vehicle
- Basic mechanics tool set (SAE/Metric sockets and combination wrenches)
- 0-150 ft.-lbs. torque wrench
- Quick disconnect tools for fuel connections (EFI applications)
- Timing light, vacuum gauge, and spark plug gap tool
- 7/16"-14 or 1/2"-13 tap and handle
- 3/16" drill bit (not required for all applications)
- Straightedge
- Feeler gauge
- Modeling clay
- Adjustable pushrod (TFS-9001)
- Solid mock up lifter

Additional Parts Required

These components are required to complete the installation of your new cylinder heads. Please refer to the Recommended Components chart on the Technical Specifications sheet for specific part numbers.

- Head gaskets
- Intake gaskets
- Exhaust gaskets
- Head bolts
- Head bolt bushings
- Intake bolts
- Exhaust bolts
- Moly lube
- Spark plugs
- RTV sealer
- Pushrods
- Rocker arms
- Cylinder head locating dowels
- Thread locker
- Thread sealer

Installation Instructions

1) Cylinder Head Removal

Consult your shop manual for the proper cylinder head removal procedure for your vehicle. Taking notes, pictures, and even making a video of the disassembly will help you greatly when reinstalling brackets and routing vacuum lines.

NOTE: Be sure cylinder #1 is at TDC on the compression stroke and mark the distributor's rotor position on the firewall before disassembly.

2) Prepping the Block

With the old cylinder heads removed, inspect the cylinder bores for scratches, ridges, and cracks. If everything appears to be OK, put some paper towels in the cylinders to catch loose debris as the old head gaskets are scraped off the engine block's deck surface. Remove all traces of the gaskets and any oil or grease that may be present by wiping the surface with brake cleaner.

Check the deck surfaces for flatness by laying a straightedge across the deck lengthwise and sticking a .004" feeler gauge under it. If the feeler gauge fits anywhere under the straightedge, the block will need to be decked or head gasket failure will result.

Once the block decks have been cleaned and checked, use the correct size tap to chase the threads in the bolt holes. This will clean out old sealer and debris, which is extremely important for preventing leaks and torquing the heads down evenly on the block.

After cleaning the head bolt hole threads, carefully remove the paper towels from the cylinders and discard. Using new paper towels clean the cylinders and coat the cylinder walls with a thin film of engine oil to protect them from corrosion.

Next, install the new head alignment dowels, and then place the new head gaskets on the engine block.

If the cylinder heads are being installed on a 351 SVO or pre-1972 engine block, the coolant passages in the deck surface of the block must be modified. This modification must be done to prevent overheating due to steam pockets forming in the high side of the block.

Start this procedure by taping off or otherwise covering the deck surface.

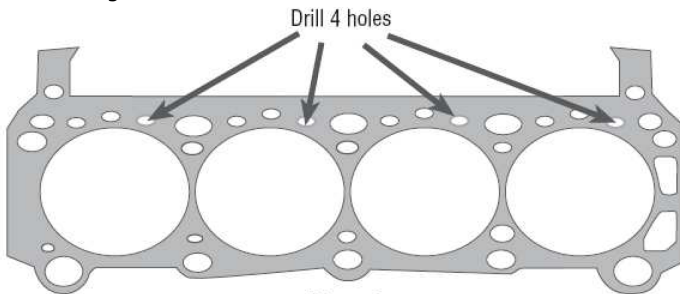

Using the head gasket as a template, drill into the water jacket at the locations shown with a 3/16" drill bit.

WARNING: OEM-style dome pistons will interfere with the Twisted Wedge 11R cylinder heads' unique combustion chamber design. Conventional flat top pistons will work, and many aftermarket manufacturers make a Twisted Wedge-specific piston for high compression and high valve lift applications.

3) Checking Exhaust Manifold/Header Clearance

Place one of the Twisted Wedge 11R cylinder heads on a suitable work stand and install the recommended spark plugs (refer to the Recommended Components chart on the Technical Specifications sheet for specific part numbers). Bolt the exhaust manifold/headers to the cylinder head and check for any interference. Repeat this procedure on the other cylinder head.

4) Checking Piston-to-Valve Clearance and Valvetrain Geometry

If you choose to use the stock camshaft in your engine, and it has not been moved from its factory position, you do not have to check piston-to-valve clearance. If you have an aftermarket camshaft or are reinstalling a camshaft (especially with a multi-keyway timing set), you must follow this procedure to assure safe operating clearances between your pistons and valves:

- A) Rotate the crankshaft until the engine is on the compression stroke of the #1 cylinder. Place a solid mock up lifter in the lifter bore of the valve that you will be measuring. Be sure that the mock up lifter is the same height as the lifters that will be installed in the engine later.
- B) Coat the top of the piston with a very thin layer of oil, and then place a few 1/4" thick pieces of modeling clay across the upper half of the piston. Place the head gasket you will be using on the block and bolt the head on with five or six head bolts.
- C) Install the rocker arm stud guideplate and the rocker arm for the valve you are checking (intake or exhaust). Next, set the adjustable pushrod tool to the proper length for your combination (refer to the How to Optimize Pushrod Length for Better Performance supplement for specific instructions). Tighten the rocker to zero lash, rotate the crankshaft at least twice, remove the cylinder head.
- D) Gently cut the clay into slices and look for the thinnest section of the valve impression. The impression is a 3D representation of the clearance between the piston and valve. Carefully measure the thickness of the clay with a machinist's scale or calipers. The intake valve side of the clay should have .080" or more of clearance, and the exhaust should have .100" or more of clearance.
- E) When you are finished measuring the second valve, reinstall the cylinder head in the same manner as before so you can verify proper pushrod length and valvetrain geometry. The procedure can be found in the bulletin titled "How to Optimize Pushrod Length for Better Performance".
- F) When you have completed these procedures, rotate the crankshaft until the #1 piston is at TDC on the compression stroke.

NOTE: Reference the maximum recommended valve lift for the valve springs in the Technical Specifications sheet before purchasing an aftermarket camshaft.

5) Installing the Twisted Wedge® 11R Cylinder Heads

With the block deck surfaces and cylinders clean and all checks completed, position the head gaskets on the block per the manufacturer's markings.

Don't be alarmed if some of the holes in the block are restricted by a smaller hole in the gasket. This is done intentionally to regulate coolant flow.

Position each cylinder head evenly on the block's dowel pins so that each head lies flat against the gasket. Place a small amount of ARP moly lube on the tops of your head bolt washers. Washers are required to prevent galling of the aluminum and to get accurate torque readings. Coat the threads of your head bolts with Permatex 3H Aviation Form-A-Gasket (bolts), or blue Loctite (studs), following the manufacturer's directions for set-up time, and then place the bolts in their proper locations. Torque the bolts in the four stages shown, following the sequence shown below.

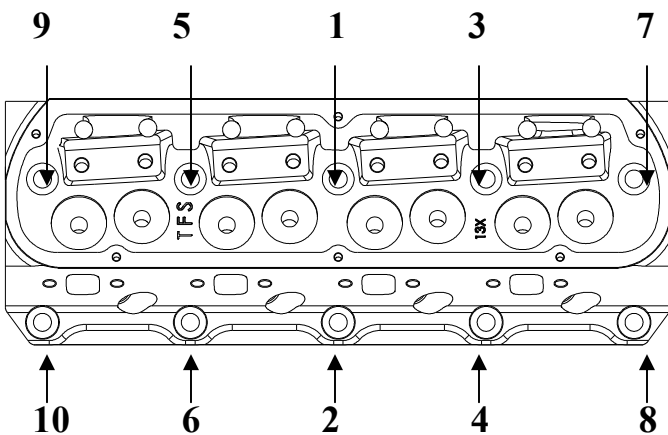

7/16" Head Bolts:

Stage One:	30 ft.-lbs.
Stage Two:	40 ft.-lbs.
Stage Three:	50 ft.-lbs.
Stage Four:	65-70 ft.-lbs.

1/2" Head Bolts:

Stage One:	30 ft.-lbs.
Stage Two:	60 ft.-lbs.
Stage Three:	90 ft.-lbs.
Stage Four:	100-110 ft.-lbs.

It is not necessary to re-torque the head bolts after initial break-in. For head stud installation, follow the head stud manufacturer's instructions.

6) Installing and Adjusting the Valvetrain

Place the proper length, hardened pushrods into the pushrod holes. Use a thread sealer on the threads of the rocker studs, and then put the guideplates on. With everything installed, torque the rocker arm studs to 55 ft.-lbs. Place the rocker arms on the studs and verify that they are centered side to side.

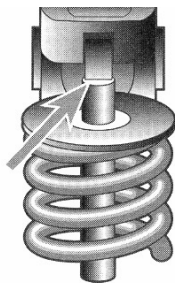

Adjust the valvetrain according to the camshaft manufacturer's recommendations. If you are using a hydraulic camshaft and no specifications are available, turn the rocker arm adjusting nuts $\frac{1}{2}$ to $\frac{3}{4}$ of a turn past zero lash. For mechanical camshafts, you must use the correct lash specification determined by the camshaft manufacturer.

Use the following adjustment order for all types of camshafts:

- Following the proper firing order for your engine, turn the crankshaft until the first cylinder listed in the firing order is at TDC on the compression stroke. Both valves will be in the closed position.
- Adjust the valves as described, then rotate the crank exactly $\frac{1}{4}$ turn and repeat for the next cylinder in the firing order.
- After the valvetrain for all the cylinders has been adjusted, set the #1 piston at TDC on the compression stroke for the rest of the reassembly.

Firing Order:

289 and Standard 302/5.0L: 1-5-4-2-6-3-7-8
351W and 5.0L HO: 1-3-7-2-6-5-4-8

7) Reassembling the Rest of the Engine

Install as many items as you can without putting the valve covers on. This will allow you to pre-lube the valvetrain, which is explained in the 'Pre-lubing the Valvetrain' section. Be sure to seal your intake manifold bolts with a thread sealer to avoid any coolant seepage.

Exhaust Leak Note: What may sound like a lifter tick is often an exhaust gas leak. Rule out exhaust leaks before tearing the intake off to replace the lifters.

8) Pre-lubing the Valvetrain

The valvetrain is now ready to be pre-lubed. Use an oil pump primer to pre-lube the valvetrain. Next, slowly pour a half quart of motor oil (per head) over the rocker arms, valve springs, and valve stems. Use an oil squirt can to get inside the valve spring and lube the valve stem and seal area. Reinstall the valve covers as soon as possible to keep contaminants out of the engine.

DO NOT START THE ENGINE IF THE TOP HALF OF THE ENGINE HAS NOT BEEN PRELUBED!

Finish reassembling all other components, brackets and vacuum lines.

9) Break-In and Tuning

To ensure long life and trouble-free use, allow 2-4 hours of normal driving time before running the engine hard; this will break-in the valvetrain properly.

Trick Flow Specialties®, Trick Flow®, TFS® and Twisted Wedge® are trademarks of Trick Flow Specialties, registered U.S. Pat. Off.

Trick Flow Twisted Wedge heads for small block Ford are not a product of Ford Motor Company, nor are they endorsed by Ford. Trick Flow Specialties is not affiliated with Ford in any manner whatsoever.

Replacement Cylinder Heads

TFS-5251B560-C00, 56cc CNC chambers, 170cc CNC Street Ported, bare, each

TFS-5251B610-C00, 61cc CNC chambers, 170cc CNC Street Ported, bare, each

TFS-5251B560-C01, 56cc CNC chambers, 190cc CNC Street Ported, bare, each

TFS-5251B660-C01, 66cc CNC chambers, 190cc CNC Street Ported, bare, each

TFS-5261B560-C02, 56cc CNC chamber, 190cc CNC Competition Ported, bare, each

TFS-5261B660-C02, 66cc CNC chamber, 190cc CNC Competition Ported, bare, each

TFS-5261B560-C03, 56cc CNC chamber, 205cc CNC Competition Ported, bare each

TFS-5261B660-C03, 66cc CNC chamber, 205cc CNC Competition Ported, bare, each

TFS-52515601-C00, 56cc CNC chamber, 170cc CNC Street Ported, 1.300" dual spring, 2.020" intake valve, assembled, each

TFS-52516101-C00, 61cc CNC chamber, 170cc CNC Street Ported, 1.300" dual spring, 2.020" intake valve, assembled, each

TFS-52515601-C01, 56cc CNC chamber, 190cc CNC Street Ported, 1.300" dual spring, 2.055" intake valve, assembled, each

TFS-52516601-C01, 66cc CNC chamber, 190cc CNC Street Ported, 1.300" dual spring, 2.055" intake valve, assembled, each

TFS-52615601-C02, 56cc CNC chamber, 190cc CNC Competition Ported, 1.300" dual spring, 2.055" intake valve, assembled, each

TFS-5261T561-C02, 56cc CNC chamber, 190cc CNC Competition Ported, 1.300" dual spring, 2.055" intake valve, assembled, each

TFS-52616601-C02, 66cc CNC chamber, 190cc CNC Competition Ported, 1.300" dual spring, 2.055" intake valve, assembled, each

TFS-5261T661-C02, 66cc CNC chamber, 190cc CNC Competition Ported, 1.300" dual spring, 2.055" intake valve, assembled, each

TFS-52615601-C03, 56cc CNC chamber, 205cc CNC Competition Ported, 1.300" dual spring, 2.080" intake valve, assembled, each

TFS-5261T561-C03, 56cc CNC chamber, 205cc CNC Competition Ported, 1.300" dual spring, 2.080" intake valve, assembled, each

TFS-52616601-C03, 66cc CNC chamber, 205cc CNC Competition Ported, 1.300" dual spring, 2.080" intake valve, assembled, each

TFS-5261T661-C03, 66cc CNC chamber, 205cc CNC Competition Ported, 1.300" dual spring, 2.080" intake valve, assembled, each

Recommended Components

Head gasket: Trick Flow # TFS-51494030-040
Trick Flow # TFS-51494060-040

Intake gasket: Fel-Pro # 1250 (C00)
Fel-Pro # 1262 (C01, C02)
Fel-Pro # 1262R (C03)
Trick Flow # TFS-52400921 (C03)

Exhaust gasket: Fel-Pro # 1415

Head bolts/studs: Trick Flow # TFS-92005 (7/16")
ARP # ARP-154-3603 (1/2")

Head Bolt Bushings: Trick Flow # TFS-51400419

Head Alignment Dowels: Trick Flow # TFS-51400420

Pistons: OEM

Rocker arms: TFS-51400520 (1.6 ratio)
TFS-51400521 (1.7 ratio)

Spark plugs: Autolite # 3924

NOTE: 1/2" head bolts are standard; TFS-51400419 reducer bushings required to use 7/16" head bolts.

TFS-IN-24 Rev. 1

Specifications

Head Material: A-356-T61 Aluminum

Comb. Chamber volume: 56cc, 61cc or 66cc CNC profiled

Intake port volume: 170cc Street ported (C00)
190cc Street ported (C01)
190cc Competition ported (C02)
205cc Competition ported (C03)

Intake port dimensions: 2.000 x 1.200 (C00)
2.100 x 1.280 (C01, C02)
2.250 x 1.400 (C03)

Intake port location: Stock

Intake valve diameter: 2.020" (C00) (TFS-52500211)
2.055" (C01, C02) (TFS-52500213)
2.080" (C03) (TFS-52500215)

Intake valve angle: 11°

Intake valve stem diameter: 8mm

Exhaust port volume: 66cc CNC Street or Competition ported

Exhaust port dimensions: 1.25 x 1.480"

Intake port location: Stock

Exhaust valve diameter: 1.60" (TFS-52500212)

Exhaust valve angle: 13°

Exhaust valve stem diameter: 8mm

Valve guide material: Bronze Alloy (TFS-52500251)

Valve seal: Viton® Fluoroelastomer canister (TFS-30600455)

Valve seat intake: Ductile Iron (TFS-52500271)

Valve seat exhaust: Ductile Iron (TFS-30600274)

Valve seat angles: 45° Seats (5 Angle Intake, 3 Angle Exhaust)

Valve spring pockets: 1.640"

Valve spring I.D. locator: 1.300" (TFS-21400442)

Valve spring retainers:

Chromemoly steel 7° x 1.300" O.D.(TFS-21400415)

Titanium 7° x 1.300" O.D. (TFS-214T0415)

Valve stem locks: 7° steel bead lock (TFS-30600444)

Valve springs: Standard

1.300" O.D. dual spring with damper (TFS-16306)

150 lbs. @ 1.800" installed height

438 lbs. @ 1.200" open

448 lbs. per inch rate

.600" maximum lift

Minimum bore diameter: 4.000"

Milling specifications: NA

Guide plates: 5/16" (TFS-51400623)

3/8" (TFS-51400624)

Push rod length: Longer than stock required,
Refer to instructions for recommendations

Rocker studs: 7/16" (TFS-51400614)

Rocker arm type: Stud Mount

Weight: 24 lbs. each, bare

Viton® is a registered trademark of DuPont Performance Elastomers.

How to Optimize Pushrod Length For Better Performance

Instruction Manual

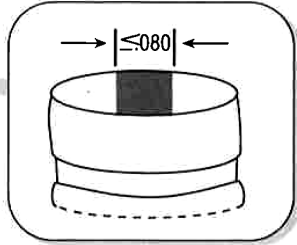

Figure 1

In an overhead valve V8 engine, the valvetrain multiplies and transfers the motion of the camshaft and lifters to the valves. The pushrods play a critical role in this transfer of motion.

Pushrod length greatly affects the efficiency of the motion transfer to the valves by altering the tip travel of the rocker arms. To provide maximum valvetrain efficiency with minimum side thrust against the valve guide, rocker arm tip travel on the valve stem should be .080" or less, as shown in **Figure 1**.

Measuring Pushrod Length

To determine the proper length pushrods for your application, you will need an adjustable checking pushrod, a machinist's rule, and the rocker arms to be used on the engine. If you are using roller rocker arms, a dial indicator will also be required.

As a general rule, longer pushrods will decrease rocker arm tip travel. This can be checked by marking one of the valve stem tips with bluing or a marker, then turning the engine over by hand a few times. This lets the rocker arm tip simulate a wear pattern on the valve stem tip. Next, take the rocker arm off; the amount of rocker arm tip travel will show up as a brightly colored stripe on the valve stem tip. Measure this stripe with the machinist's rule and make and test necessary pushrod length changes with the adjustable checking

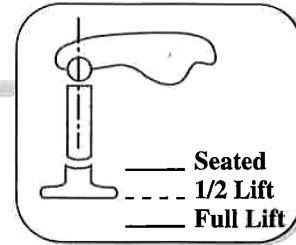

Figure 2

pushrod. If you can't get a tip travel measurement of .080" or less after trying several pushrod lengths, you will have to switch to another brand of rocker arms and start over.

When checking pushrod length with roller tip rocker arms, note the position of the roller tip on the valve stem when the valve is at one-half of its net lift. This is called half-lift centering; a dial indicator must be used to make this measurement. Ideally, the centerline of the rocker arm's roller tip should coincide with the centerline of the valve at one-half of its net lift—providing an equal amount of rocker arm tip travel on each half of the valve stem tip. A slightly off-center rocker arm tip position at half-lift is OK as long as tip travel is minimized. Refer to **Figure 2**.

It must be noted that using a different brand of rocker arms from those originally measured, even if they have the same ratio, could change the rocker arm tip travel (even if the same length pushrods are used). If either the rocker arms or pushrod length are changed, you must redetermine and reset pushrod length.

Taking the time to properly check pushrod length will reward you with better performance, less valvetrain wear, and reduced breakage. If you have questions about checking pushrod length or pushrod/rocker arm recommendations for your combination, contact the Trick Flow Technical Department at 1-330-630-1555, Monday through Friday from 9:00 am to 5:00 pm ET.

Trick Flow
Specialties
Ultimate Bolt-on Performance!

Trick Flow Specialties
1248 Southeast Avenue
Tallmadge, Ohio 44278

Sales: (330) 630-1555
Fax: (330) 630-5565
Web: TrickFlow.com

Ultimate Bolt-On Performance® Lifetime Warranty

Trick Flow Specialties cylinder head castings are backed by a lifetime warranty. If a cylinder head casting fails to provide the original purchaser with complete satisfaction, Trick Flow Specialties will repair or replace it free of charge- guaranteed!

Moreover, the valves, valve guides, valve seats, valve job, valve springs, valve spring retainers, valve locks, rocker arm studs, guideplates, and valve stem seals included on assembled Trick Flow Specialties cylinder heads are warranted to the original purchaser to be free from defects in materials and workmanship for a period of two years from the date of purchase. All other Trick Flow Specialties products are warranted to be free from defects in materials and workmanship for a period of 90 days. There are no mileage limitations.

Extent of Warranty

Customers who believe they have a defective product should return it to the dealer from which they purchased or ship it freight prepaid to Trick Flow Specialties along with proof of purchase and a complete description of the problem. If a thorough inspection indicates defects in materials or workmanship, our sole obligation is to repair or replace the product.

This warranty is only if the product is properly installed, subjected to normal use and service, did not fail due to owner negligence or misuse, and has not been altered or modified.

Trick Flow Specialties warranties do not cover any installation or removal costs.

Trick Flow Specialties is not liable for consequential damages for breach of contract of any warranty in excess of the purchase price of the product sold.

Trick Flow Specialties

1248 Southeast Avenue Tallmadge, Ohio 44278
Sales: (330) 630-1555, Fax: (330)630-5565
Web: Trickflow.com