

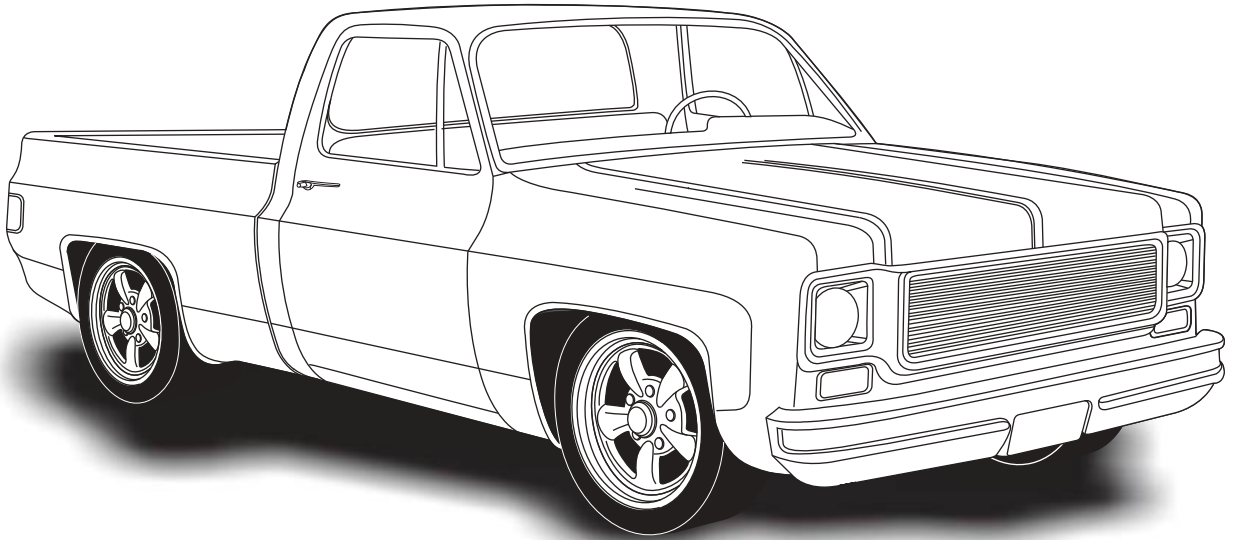

# **1981-87 Chevrolet Pickup**

*with Factory Air*  
**Gen 5 Evaporator Kit**  
**(755621)**



**18865 Goll St. San Antonio, TX 78266**  
**Phone: 800-862-6658**  
**Sales: [sales@vintageair.com](mailto:sales@vintageair.com)**  
**Tech Support: [tech@vintageair.com](mailto:tech@vintageair.com)**  
**[www.vintageair.com](http://www.vintageair.com)**



[www.vintageair.com](http://www.vintageair.com)

# Table of Contents

Cover.....	1
Table of Contents.....	2
Packing List/Parts Disclaimer.....	3
Information Page.....	4
Wiring Notice.....	5
Engine Compartment Disassembly, Condenser Assembly and Installation, Compressor and Brackets.....	6
Passenger Compartment.....	7
Defrost Duct Installation, Fresh Air Cap Installation and Firewall Modification.....	8
Firewall Modification (Cont.), Firewall Cover Installation.....	9
Bracket, Plenums, & Evaporator Hardline Installation.....	10
Bracket, Plenums, & Evaporator Hardline Installation (Cont.).....	11
Evaporator Installation.....	12
Drain Hose Installation, Lubricating O-rings, A/C Hose Installation.....	13
Heater Hose & Heater Control Valve Installation.....	14
A/C and Heater Hose Routing.....	15
Driver- and Passenger-Side Center Louver Hose Adapter Installation, Driver- and Passenger- Side Louver Hose Adapter Installation.....	16
Final Steps: Completing the Install.....	17
Final Steps: Installation Check.....	18
ECU, Control Panel & Duct Hose Routing.....	19
Gen 5 Wiring Diagram.....	20
Gen 5 Wiring Connection Instruction.....	21
Glove Box Modification.....	22
Quality Crimp Guideline.....	23
Operation of Controls.....	24
Troubleshooting Guide.....	25
Troubleshooting Guide (Cont.), Advanced Diagnostics and Troubleshooting Guide.....	26
Power Steering Bracket Modification.....	27
Packing List.....	28



www.vintageair.com

# Packing List: Evaporator Kit (755621)

No.	Qty.	Part No.	Description
1.	1	765200	Gen 5 Super Magnum Module
2.	1	795621	Accessory Kit

**\*\* Before beginning installation, open all packages and check contents of shipment. Please report any shortages directly to Vintage Air within 15 days. After 15 days, Vintage Air will not be responsible for missing or damaged items.**

1

**Gen 5 Super Magnum  
Module  
765200**

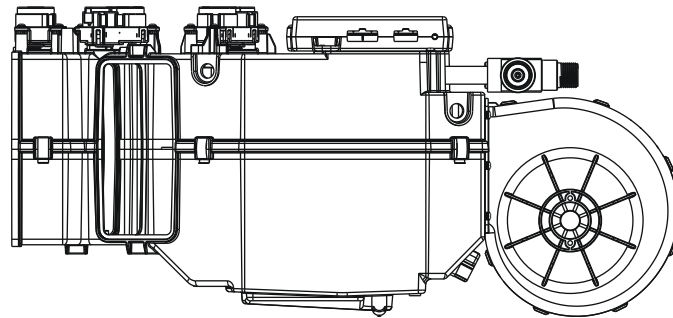

2

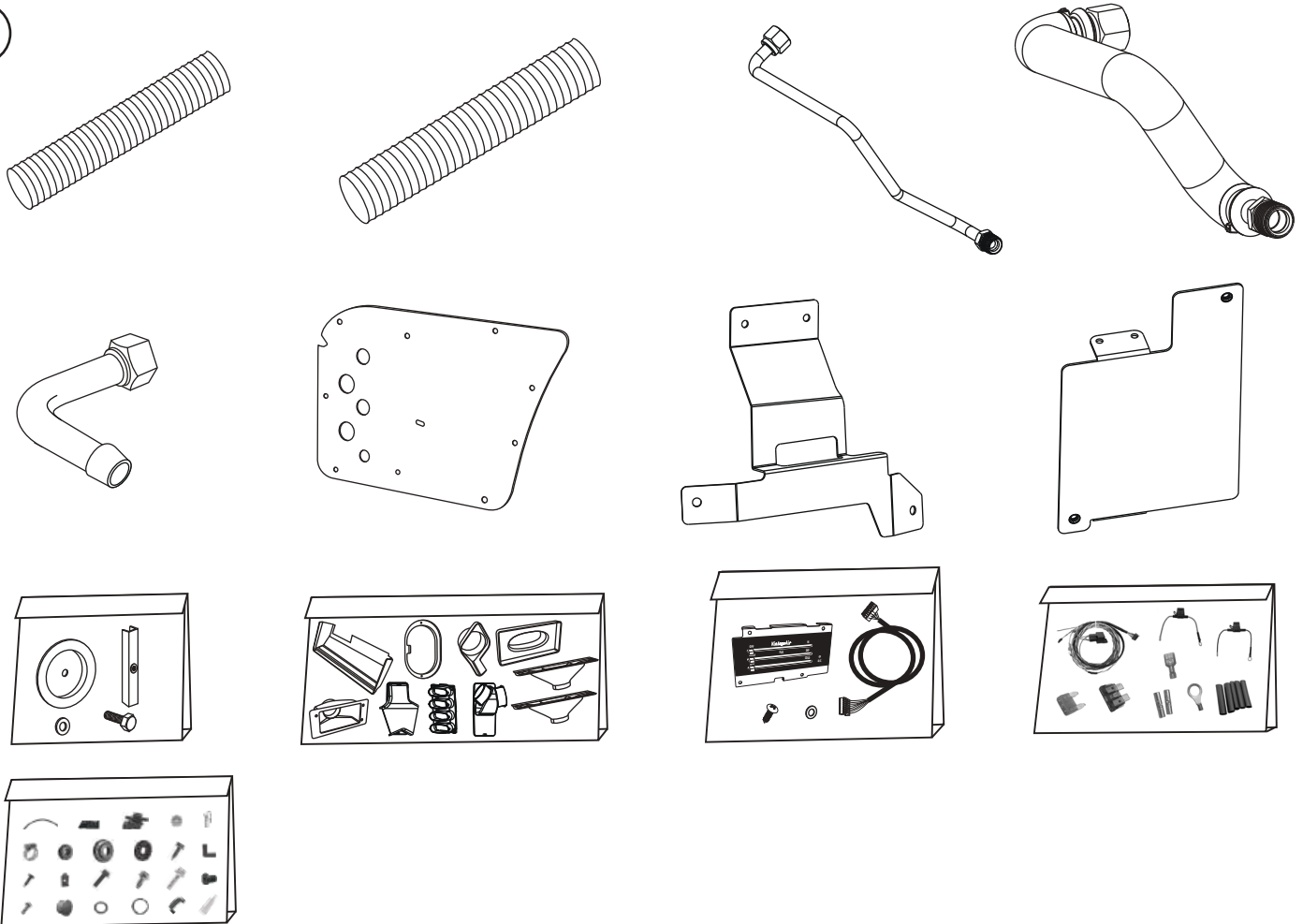

**Accessory Kit  
795621**

**NOTE: Images may not depict actual parts and quantities. Refer to packing list for actual parts and quantities.**



www.vintageair.com

## Important Notice—Please Read

*For Maximum System Performance, Vintage Air Recommends the Following:*

**NOTE:** Vintage Air systems are designed to operate with R134a refrigerant only. Use of any other refrigerant could damage your A/C system and/or vehicle, and possibly cause a fire, in addition to potentially voiding the warranties of the A/C system and its components.

### Refrigerant Capacities:

**Vintage Air System:** 1.8 lbs. (28.8 oz.) or 816 grams of **R134a**, charged by weight with a quality charging station or scale. **NOTE: Use of the proper type and amount of refrigerant is critical to system operation and performance.**

**Other Systems:** Consult manufacturer's guidelines.

### Lubricant Capacities:

**New Vintage Air-Supplied Sanden Compressor:** No additional oil needed (Compressor is shipped with proper oil charge).

**All Other Compressors:** Consult manufacturer (Some compressors are shipped dry and will need oil added).

### Safety Switches

Your Vintage Air system is equipped with a binary pressure safety switch. A binary switch disengages the compressor clutch in cases of extreme low pressure conditions (refrigerant loss) or excessively high head pressure (406 PSI) to prevent compressor damage or hose rupture. A trinary switch combines Hi/Lo pressure protection with an electric fan operation signal at 254 PSI, and should be substituted for use with electric fans. Compressor safety switches are extremely important since an A/C system relies on refrigerant to circulate lubricant.

### Service Info:

**Protect Your Investment:** Prior to assembly, it is critical that the compressor, evaporator, A/C hoses and fittings, hardlines, condenser and receiver/drier remain capped. Removing caps prior to assembly will allow moisture, insects and debris into the components, possibly leading to reduced performance and/or premature failure of your A/C system. This is especially important with the receiver/drier.

Additionally, when caps are removed for assembly, **BE CAREFUL!** Some components are shipped under pressure with dry nitrogen.

**Evacuate the System for 35-45 Minutes:** Ensure that system components (Drier, compressor, evaporator and condenser) are at a temperature of at least 85°F. On a cool day, the components can be heated with a heat gun **or** by running the engine with the heater on before evacuating. Leak check and charge to specifications.

### Bolts Passing Through Cowl and/or Firewall:

To ensure a watertight seal between the passenger compartment and the vehicle exterior, for all bolts passing through the cowl and/or firewall, Vintage Air recommends coating the threads with silicone prior to installation.

### Heater Hose (not included with this kit):

Heater hose may be purchased from Vintage Air (Part#31800-VUD) or your local parts retailer. Routing and required length will vary based on installer preference.



www.vintageair.com

## Important Wiring Notice—Please Read

*Some vehicles may have had some or all of their radio interference capacitors removed. There should be a capacitor found at each of the following locations:*

- 1. On the positive terminal of the ignition coil.**
- 2. If there is a generator, on the armature terminal of the generator.**
- 3. If there is a generator, on the battery terminal of the voltage regulator.**

Most alternators have a capacitor installed internally to eliminate what is called “whining” as the engine is revved. If whining is heard in the radio, or just to be extra cautious, a radio interference capacitor can be added to the battery terminal of the alternator.

It is also important that the battery lead is in good shape and that the ground leads are not compromised. There should be a heavy ground from the battery to the engine block, and additional grounds to the body and chassis.

If these precautions are not observed, it is possible for voltage spikes to be present on the battery leads. These spikes come from ignition systems and charging systems, and from switching some of the vehicle’s other systems on and off. Modern computer-operated equipment can be sensitive to voltage spikes on the power leads, which can cause unexpected resets, strange behavior and/or permanent damage.

Vintage Air strives to harden our products against these types of electrical noise, but there is a point where a vehicle’s electrical system can be degraded so much that nothing can help.

Radio interference capacitors should be available at most auto and truck parts suppliers. They typically are cylindrical in shape, a little over an inch long and a little over a half-inch in diameter, and they have a single lead coming from one end of the cylinder with a terminal on the end of the wire, as well as a mounting clip which is screwed into a good ground on the vehicle. The specific value of the capacitance is not too significant in comparison to ignition capacitors that are matched with the coil to reduce pitting of the points.

- Care must be taken, when installing the compressor lead, not to short it to ground. The compressor lead must not be connected to a condenser fan or to any other auxiliary device. Shorting to ground or connecting to a condenser fan or any other auxiliary device may damage wiring or the compressor relay, and/or cause a malfunction.
- When installing ground leads on Gen 5 systems, the blower control ground and ECU ground must be connected directly to the negative battery post.
- For proper system operation, the heater control valve must be connected to the ECU.



www.vintageair.com

## Engine Compartment Disassembly

**NOTE:** Before starting the installation, check the function of the vehicle (horn, lights, etc.) for proper operation, and study the instructions, illustrations & diagrams.

### Perform the Following:

1. Disconnect the battery.
2. Drain the radiator, then remove it (retain).
3. Evacuate the A/C system (if necessary).
4. Remove the OEM condenser and drier (discard) (See Figure 1, below).
5. Remove the OEM A/C lines from the compressor to the evaporator (discard).
6. Remove the OEM compressor and bracket (discard).
7. Remove the evaporator blower assembly (discard). **NOTE: To remove the evaporator, blower assembly (under hood) and the air distribution system (under dash), the factory manual recommends that you remove the right-inner fender for accessibility.**
8. Remove the OEM heater hoses, A/C hoses and hardlines (discard) (See Figure 1, below).

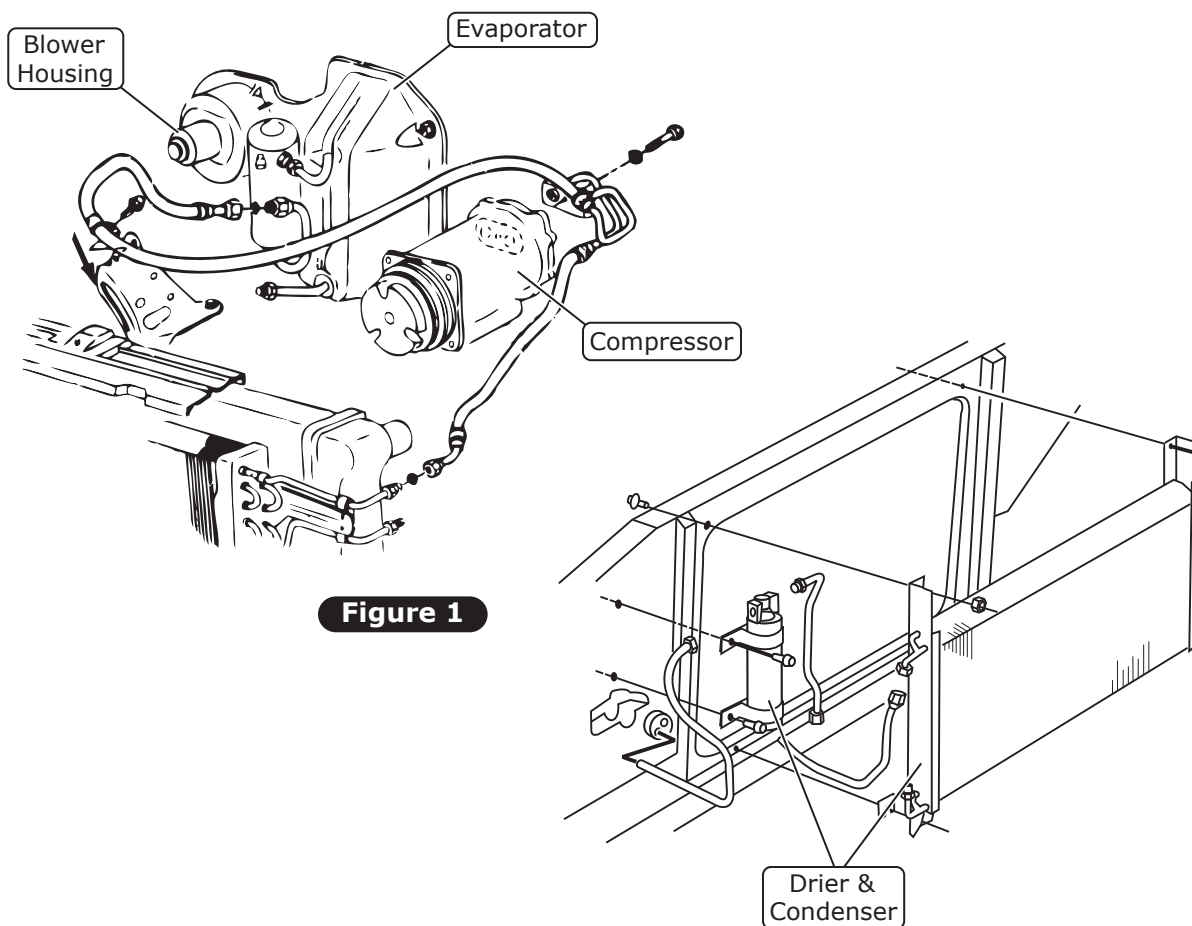

Figure 1

## Condenser Assembly and Installation

1. Refer to separate instructions included with the condenser kit to install the condenser.
2. Binary switch installation (Refer to condenser instructions).

## Compressor and Brackets

1. Refer to separate instructions included with the bracket kit to install the compressor bracket.



www.vintageair.com

## Passenger Compartment

**NOTE:** For ease of installing the evaporator under the dash, it may be helpful to remove the (2) OEM bolts under the dash on the passenger-side door pillar and pull back the dash.

### Perform the Following:

1. Remove the glove box door and glove box assembly (retain) (See Figure 1, below).
2. Remove the under dash steering column cover (retain) (See Figure 1, below).
3. Remove the instrument panel bezel (retain).
4. Remove the dash pad (retain) (See Figure 1, below).
5. Disconnect all the wires and cables from the control panel.
6. Remove the control panel (discard). Refer to the control panel kit instructions.
7. Remove the ash tray (retain).
8. Remove all the hose and ducting from the OEM louvers (See Figure 1a, below).
9. Remove the A/C & heater assembly (discard) (See Figure 1a, below).
10. Remove the defrost duct assembly (discard) (See Figure 1a, below).
11. Remove the passenger-side kick panel assembly (retain kick panel cover & kick panel cap, but discard the door and actuator) (See Figure 1b, below).
12. Apply a 1/4" bead of silicone onto the mating surface of the kick panel block-off plate.
13. Install the kick panel block-off plate using (2) #8 x 1/2" pan head screws (See Figure 1c, below).

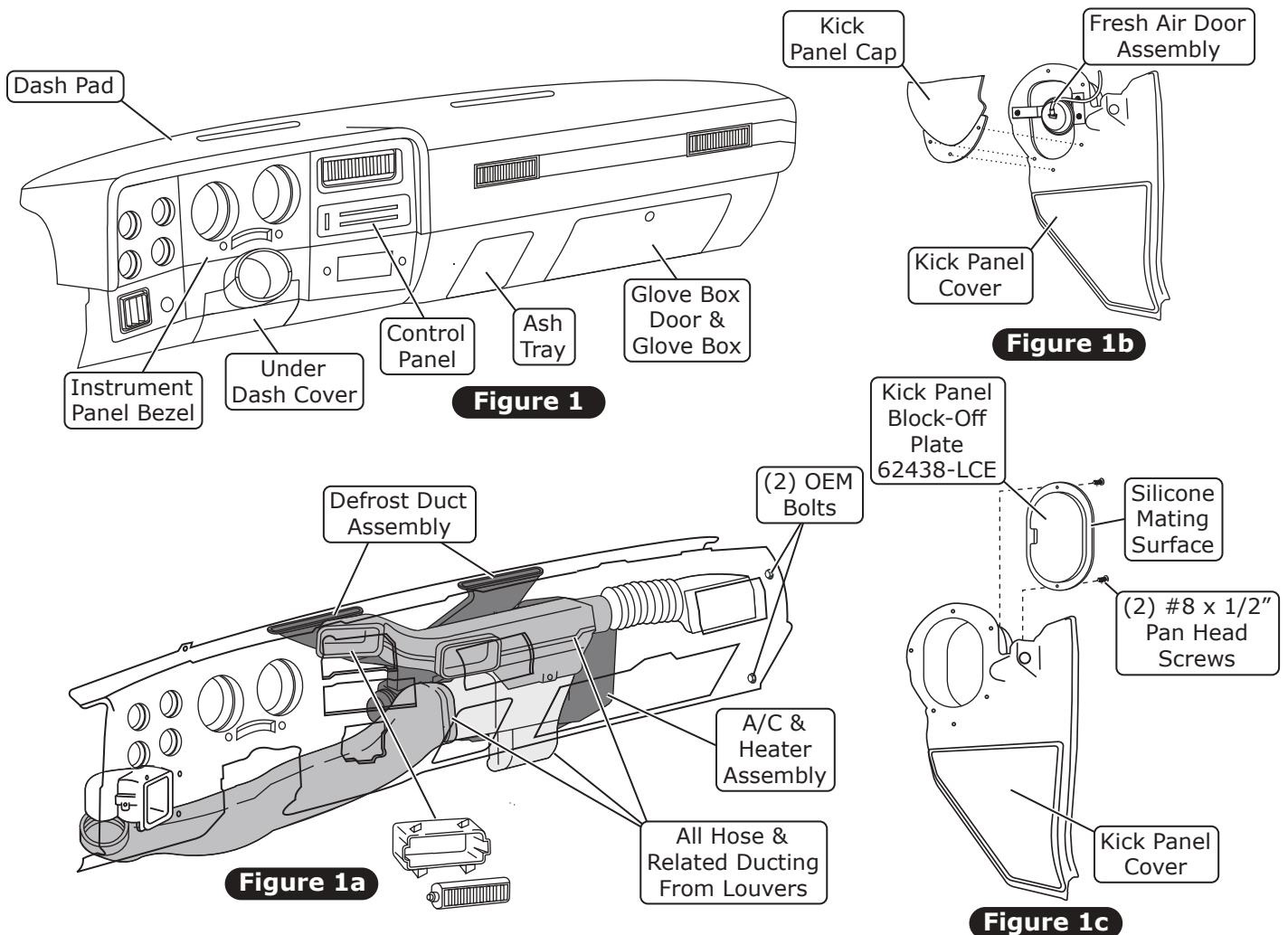



www.vintageair.com

## Defrost Duct Installation

1. Install (4) #8 U-nuts onto the OEM defrost duct openings as shown in Figure 1, below.
2. Install the driver- and passenger-side defrost ducts into the openings and secure using (4) #8 x 1/2" pan head screws (See Figure 1, below).

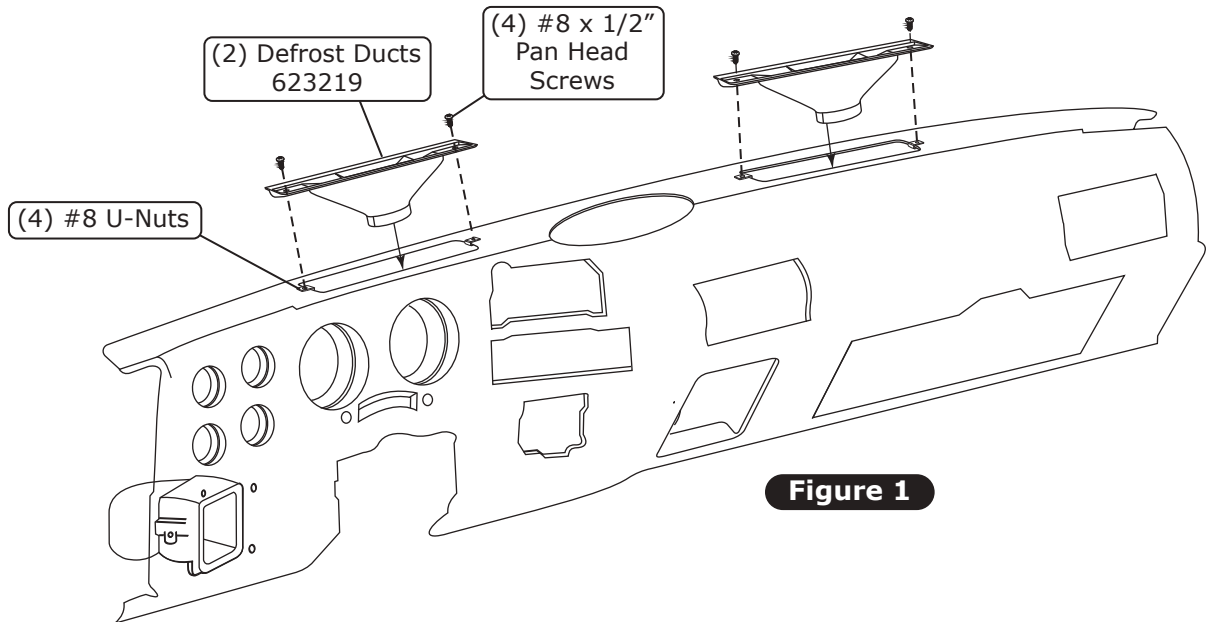

Figure 1

## Fresh Air Cap and Firewall Modification

1. Apply a 1/4" bead of silicone around the mating surface of the fresh air cap as shown in Figure 1, below.
2. Install the fresh air cap onto the firewall using a 1/4-20 x 3/4" black serrated flange bolt (See Figure 1, below).
3. Place the firewall cover onto the firewall, then secure it using (2) #14 x 3/4" sheet metal screws as shown in Figure 1, below.
4. Using the firewall cover as a template, mark the holes onto the firewall as shown in Figure 1, below.
5. Remove the firewall cover.

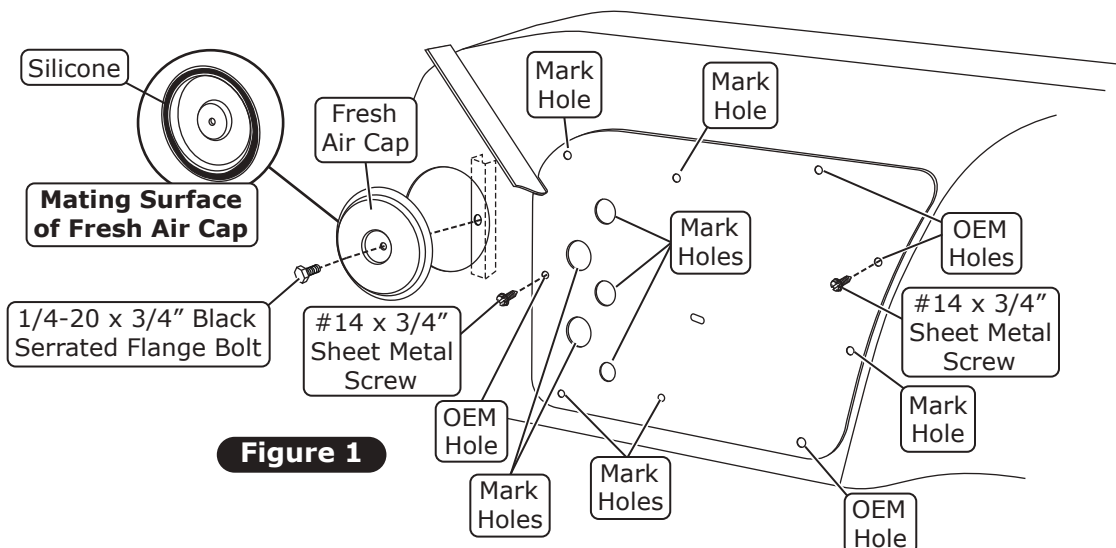

Figure 1



www.vintageair.com

# Fresh Air Cap and Firewall Modification (Cont.)

- 6. Drill the holes as shown in Figure 2, below.
- 7. Notch the inside of the top lip 3" as shown in Figure 2, below.

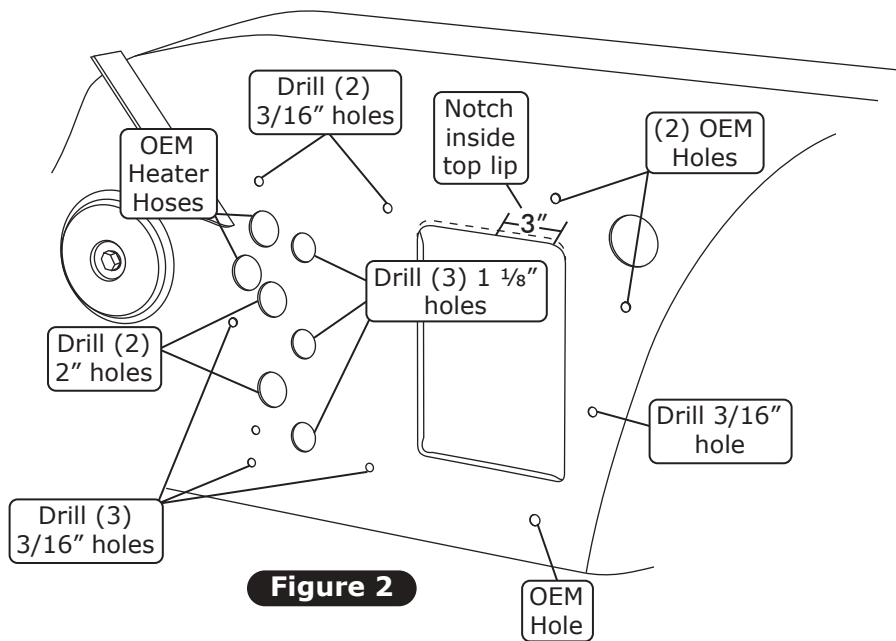

**Figure 2**

## Firewall Cover Installation

- 1. Apply a 1/4" bead of silicone around the mating surface of the firewall cover as shown in Figure 1, below.
- 2. Install the firewall cover onto the firewall using a 1/4-20 x 3/4" black serrated flange bolt, 1/4-20 nut with star washer and (8) #14 x 3/4" sheet metal screws as shown in Figure 1, below.
- 3. Install the grommets as shown in Figure 1, below.

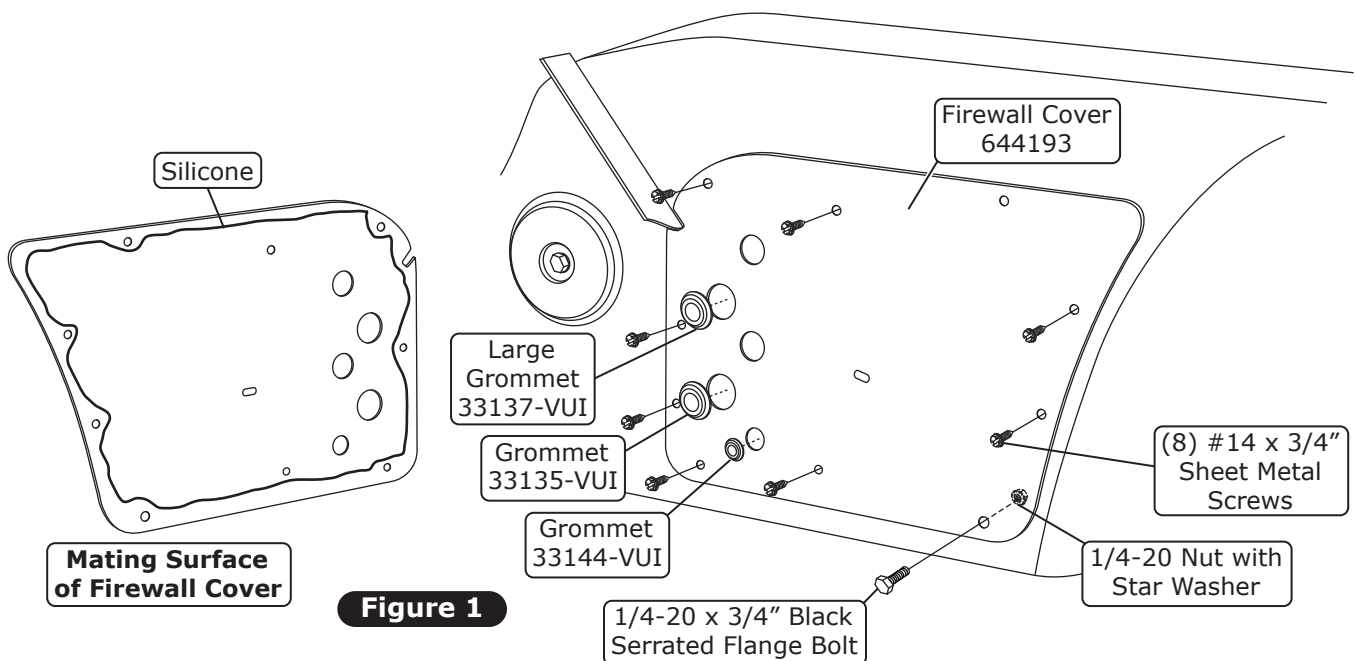

**Figure 1**



www.vintageair.com

## Bracket, Plenums & Evaporator Hardline Installation

1. Install the (3) 1/2" plastic plugs into the unused mounting provisions shown in Figure 1, below.
2. Install the floor, dash and defrost plenums using (8) spring clips as shown in Figures 1 and 1a, below.
3. On a workbench, install the evaporator rear bracket onto the module using (4) #10 x 5/8" screws (See Figure 2, Page 11).
4. Install #6 evaporator hardline, the #10 suction hardline and the (2) heater hardlines with properly lubricated O-rings (See Figure 2, Page 11 and Lubricating O-rings, Page 13). **NOTE: Wrap the #10 fitting connections with press tape (See Figure 2, Page 11).**
5. Install the evaporator front bracket onto the evaporator module using (2) 1/4-20 x 1" serrated flange bolts and (2) 1/4-20 well nuts as shown in Figure 1b, below.

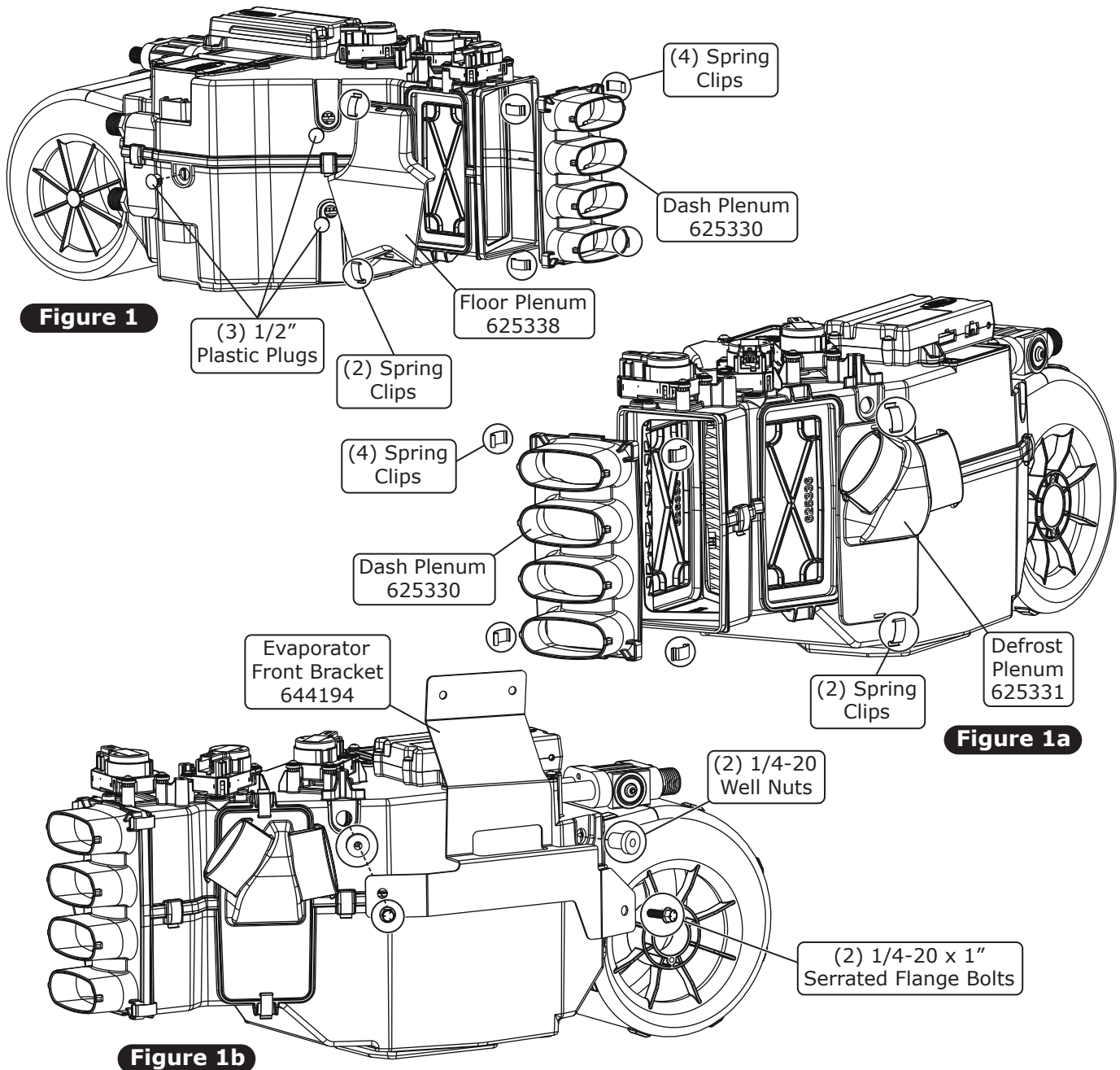

# Bracket, Plenums & Evaporator Hardline Installation (Cont.)

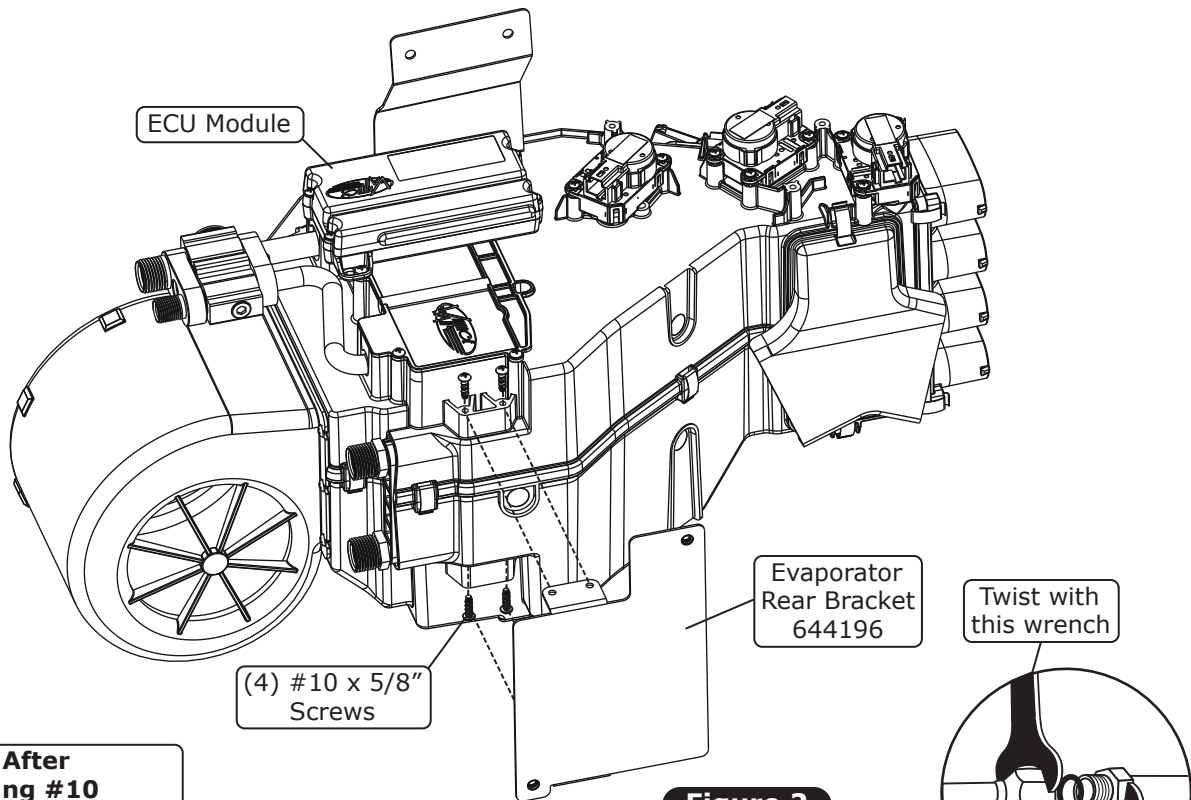

**Figure 2**

**NOTE:** After installing #10 suction hardline, wrap all exposed metal (fitting & tube) with supplied press tape

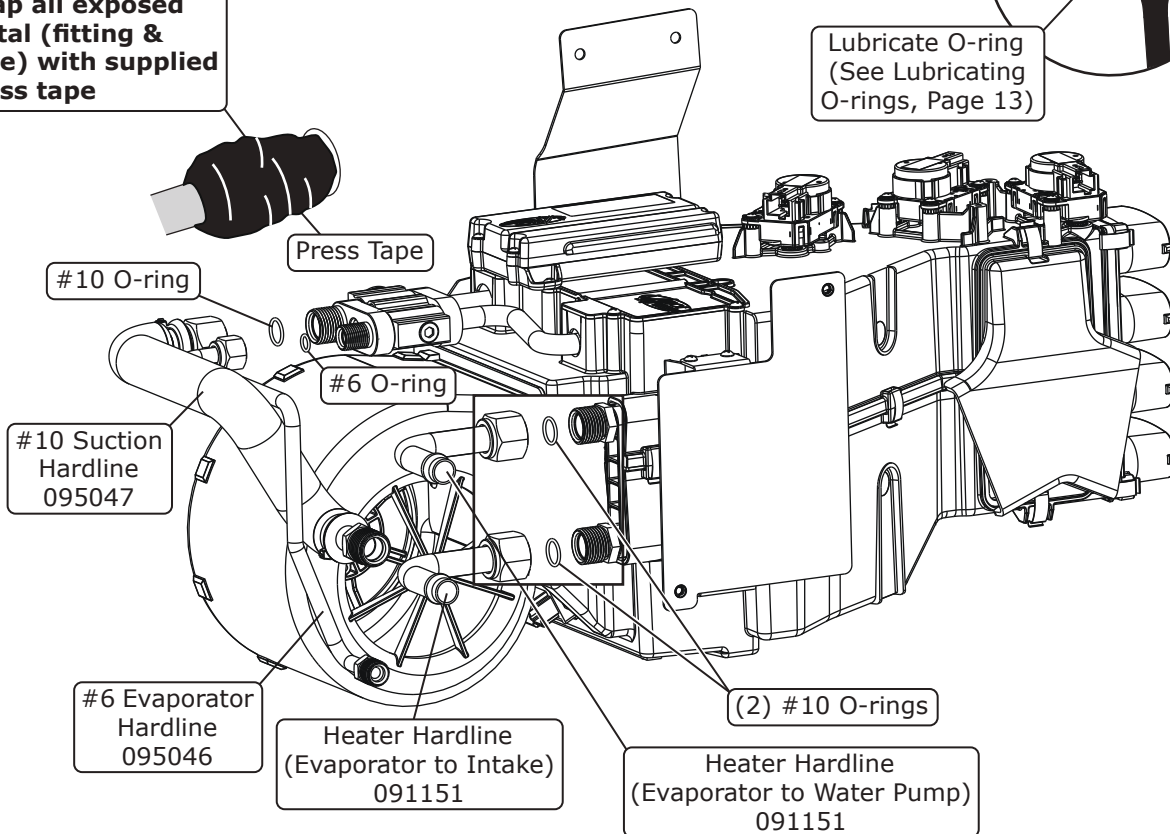



www.vintageair.com

## Evaporator Installation

**NOTE:** To ensure a watertight seal between the passenger compartment and the vehicle exterior, for all bolts passing through the firewall, Vintage Air recommends coating the threads with silicone prior to installation.

1. Lift the evaporator module up under the dashboard. Secure it loosely to the firewall using (2) 1/4-20 x 3/4" black serrated flange bolts (See Figure 1, below). **NOTE: To ensure proper drainage, it is very important that the evaporator is level, both left-right and fore-aft. Check for level on the flat portions of the case around the drain.**
2. Using (2) #12 x 1/2" self-tapping screws, secure the evaporator front mounting bracket to the cowl (See Figure 1a, below).
3. Verify the evaporator unit is level and square to the dash; then tighten all mounting bolts. **NOTE: Tighten the bolt on the firewall first. Then tighten the front mounting bracket.**
4. Reinstall the (2) OEM bolts under the dash on the passenger-side door pillar.

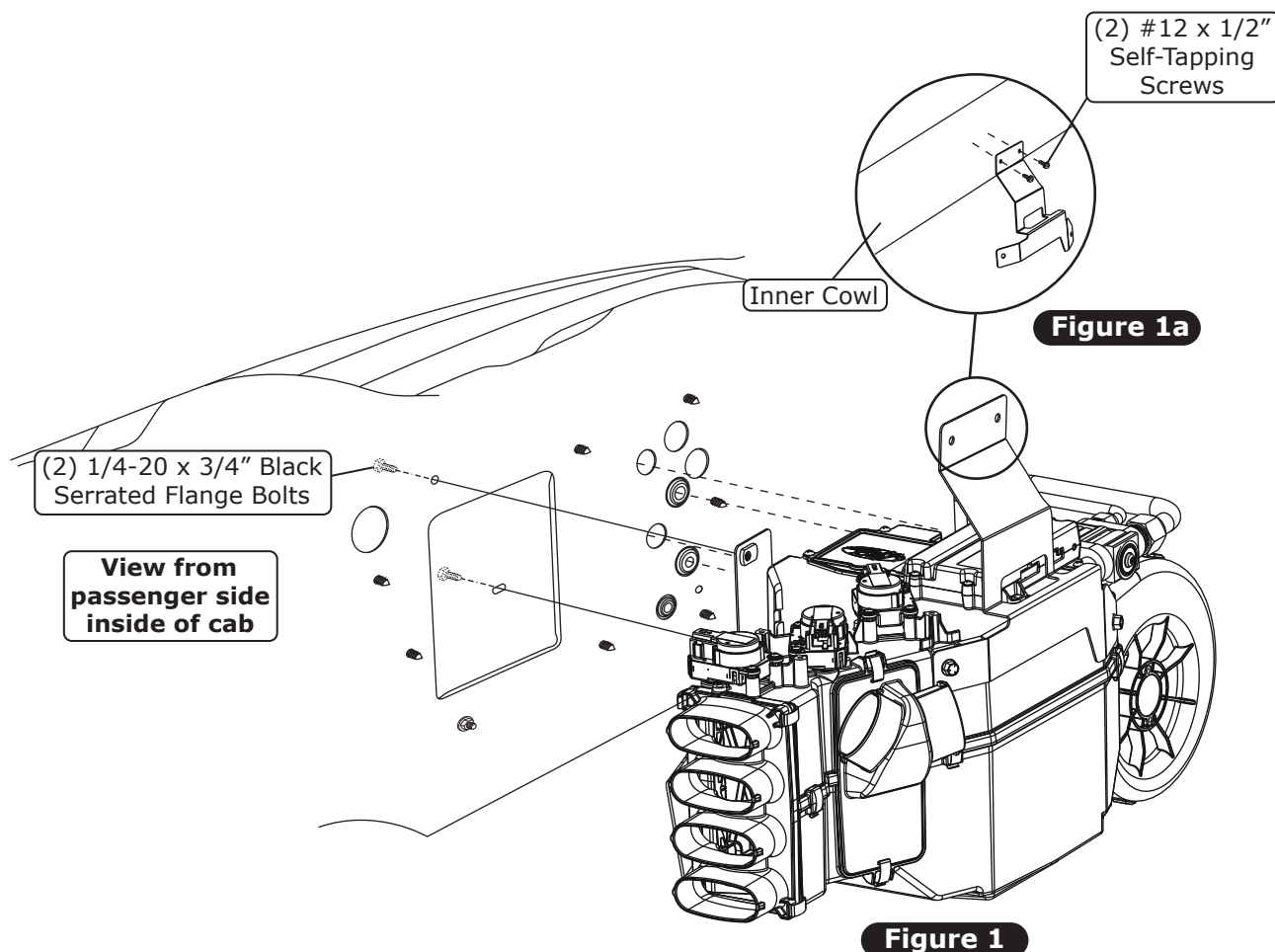



www.vintageair.com

## Drain Hose Installation

1. Locate the evaporator drain on the bottom of the evaporator module.
2. In line with the drain, lightly make a mark on the firewall. Measure 1" down, then drill a 5/8" hole through the firewall. **NOTE: To ensure a tight fit, do not enlarge the hole to more than 5/8".**
3. Install the drain hose onto the bottom of the evaporator module, then route it through the firewall. Install the 90° drain elbow onto the drain hose.

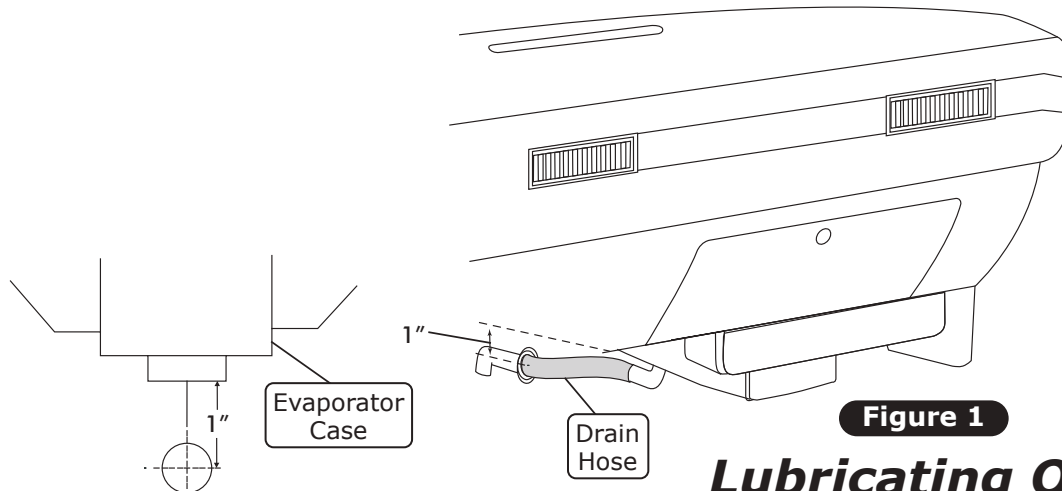
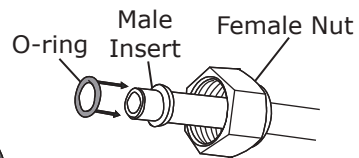
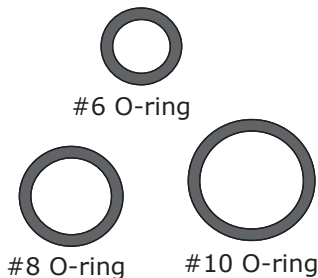

Figure 1

## Lubricating O-rings



**For a proper seal of fittings: Install supplied O-rings as shown and lubricate with refrigerant oil.**

Refrigerant Oil for O-rings

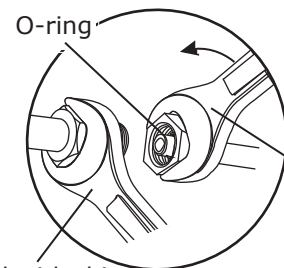
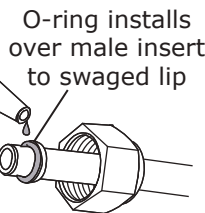

Twist with this wrench

Hold with this wrench

**NOTE: Standard torque specifications:**  
**#6: 11 to 13 ft-lb.**  
**#8: 15 to 20 ft-lb.**  
**#10: 21 to 27 ft-lb.**

## A/C Hose Installation

### Standard Hose Kit:

1. Locate the #8 compressor A/C hose. Lubricate (2) #8 O-rings (See Lubricating O-rings, above) and connect the 90° female fitting to the #8 discharge port on the compressor. Then route straight female fitting with service port to the #8 condenser hardline coming through the core support (See Figure 1, Page 15). Tighten each fitting connection as shown in Lubricating O-rings, above.
2. Locate the #10 compressor A/C hose. Lubricate (2) #10 O-rings (See Lubricating O-rings, above) and connect the #10 135° female fitting with service port to the #10 suction port on the compressor. Then route the straight female fitting to the #10 suction hardline (See Figure 1, Page 14 and Figure 1, Page 15). Tighten each fitting connection as shown in Lubricating O-rings, above.
3. Locate the #6 A/C hose. Lubricate (2) #6 O-rings (See Lubricating O-rings, above), and connect the 45° female fitting to the #6 evaporator hardline at the firewall. Then, route and connect the straight female fitting to the #6 condenser hardline coming through the core support (See Figure 1, Page 15). Tighten each fitting connection as shown in Lubricating O-rings, above.

### Modified Hose Kit:

1. Refer to separate instructions included with modified hose kit.



www.vintageair.com

## Heater Hose & Heater Control Valve Installation

1. Route the heater hose (not included) from the water pump to the heater line coming through the firewall as shown in Figure 1, below. Secure using hose clamps. **NOTE: A small amount of silicone spray will ease the heater hose installation.**
2. Route a second heater hose (not included) from the intake to the heater line coming through the firewall as shown in Figure 1, below. **NOTE: Install the heater control valve in line with the intake manifold (pressure side) heater hose.** Secure using hose clamps as shown in Figure 1, below. Note proper flow direction.
3. The hose should protrude through the firewall cover slightly to close the gap between the aluminum line and the firewall cover. Seal any remaining gap with silicone.

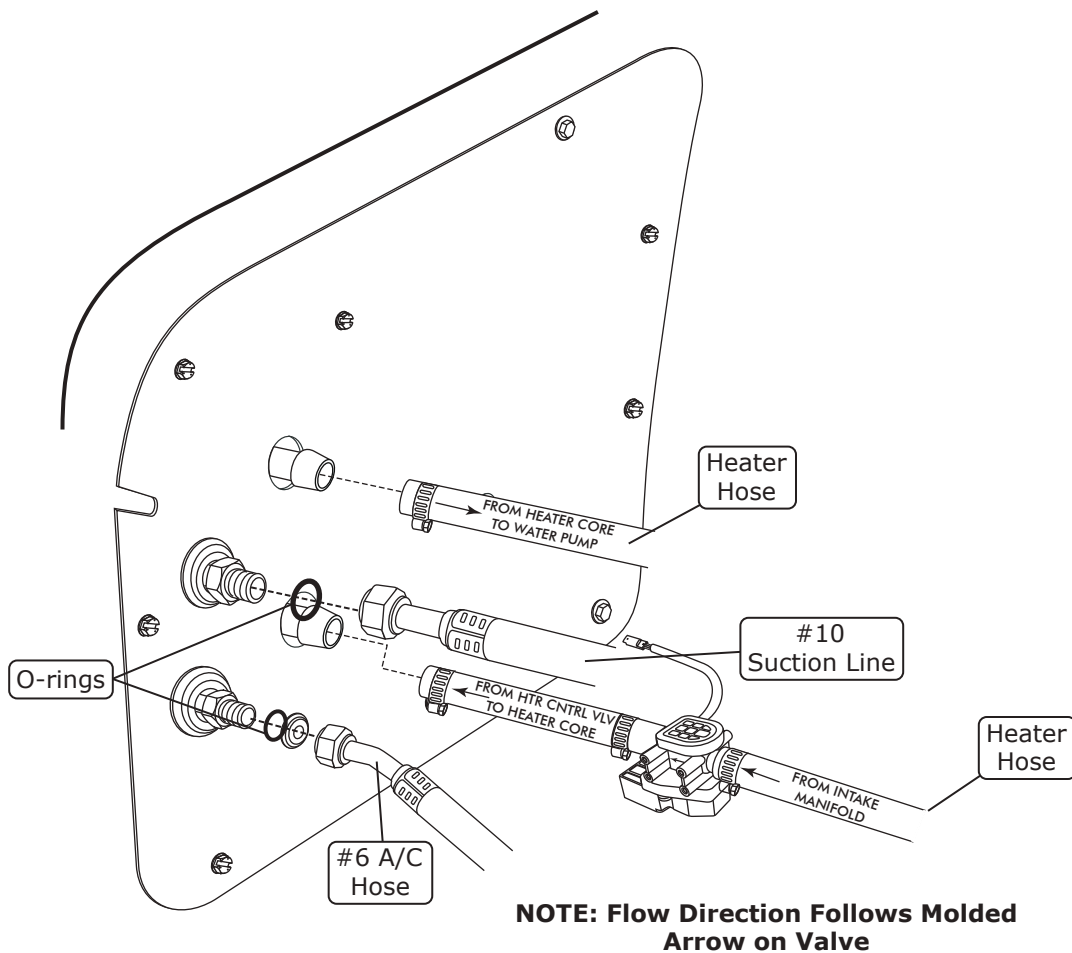

Figure 1



www.vintageair.com

# A/C and Heater Hose Routing

**NOTE:** Vintage Air Systems use 5/8" heater connections. On engines equipped with 3/4" hose nipples, these will need to be removed and replaced with 5/8" nipples (not supplied). For water pumps with a cast-in 3/4" heater outlet, a 3/4" x 5/8" reducer fitting in the heater hose (not supplied) or molded hose (Vintage Air Part # 099010) will need to be installed.

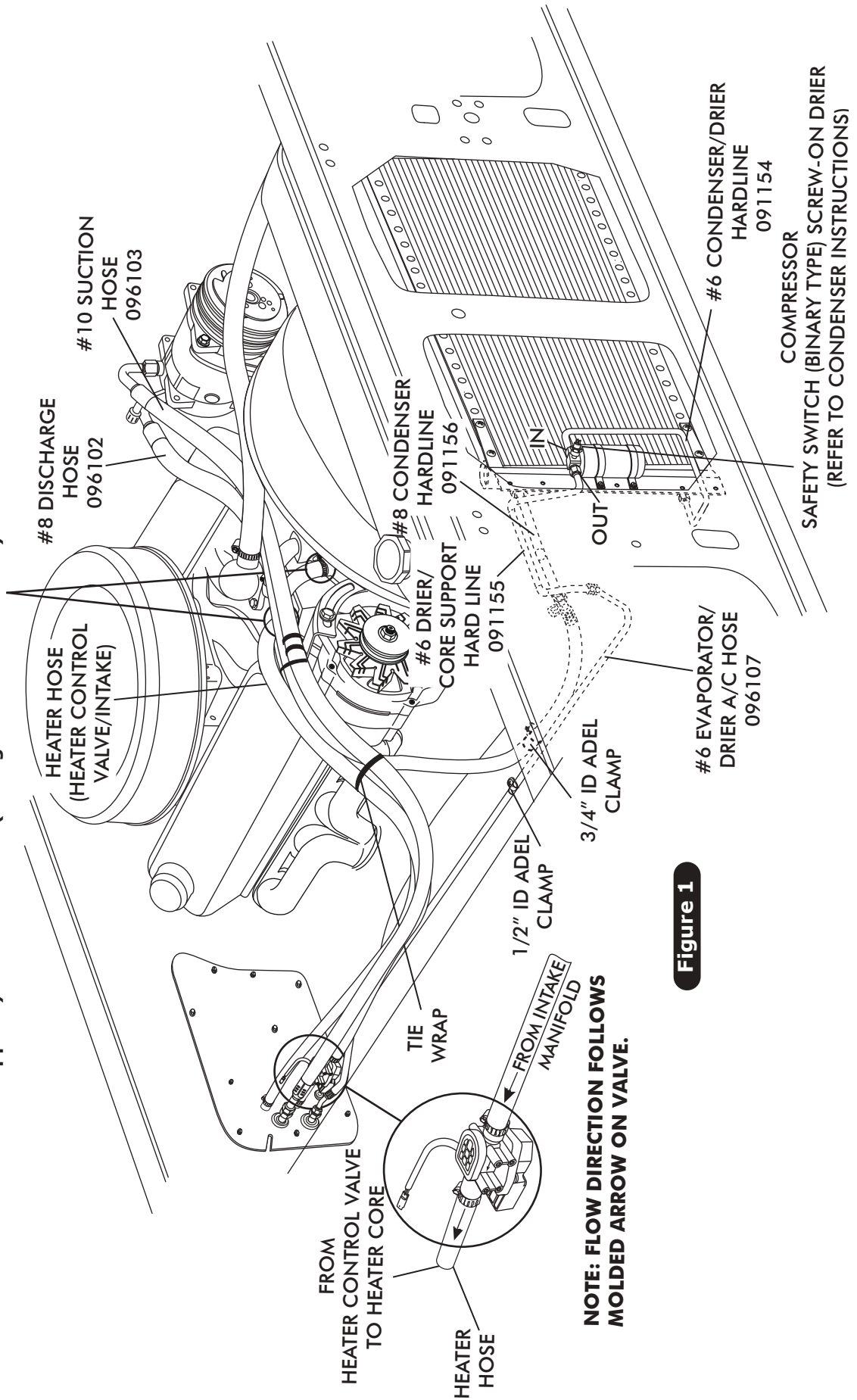

**Figure 1**



www.vintageair.com

## Driver- and Passenger-Side Center Louver Hose Adapter Installation

1. Install (4) S-clips onto the driver-side center louver hose adapter (See Figure 1, below).
2. Install the driver-side center louver hose adapter into the center louver as shown in Figure 1, below.
3. Install (4) S-clips onto the passenger-side center louver hose adapter (See Figure 1a, below).
4. Install the passenger-side center louver hose adapter into the OEM passenger-side center louver as shown in Figure 1a, below.

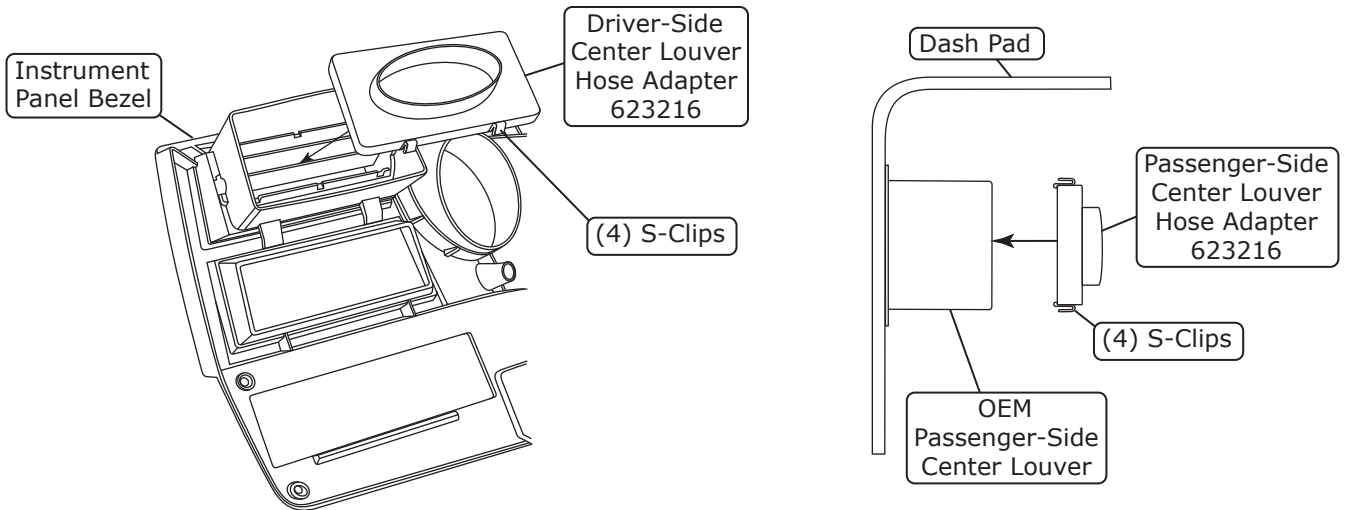

## Driver- and Passenger-Side Louver Hose Adapter Installation

1. Remove the OEM passenger-side hose adapter from the dash pad (discard) (retain (3) OEM nuts).
2. Install the passenger-side louver hose adapter onto the dash pad using (3) OEM nuts (See Figure 1, below).
3. Cut and remove the driver-side louver duct as shown in Figure 1a, below.
4. Install (4) S-clips onto the driver-side louver hose adapter as shown in Figure 1a, below.
5. Install the driver-side louver hose adapter into the driver-side louver duct as shown in Figure 1a, below.

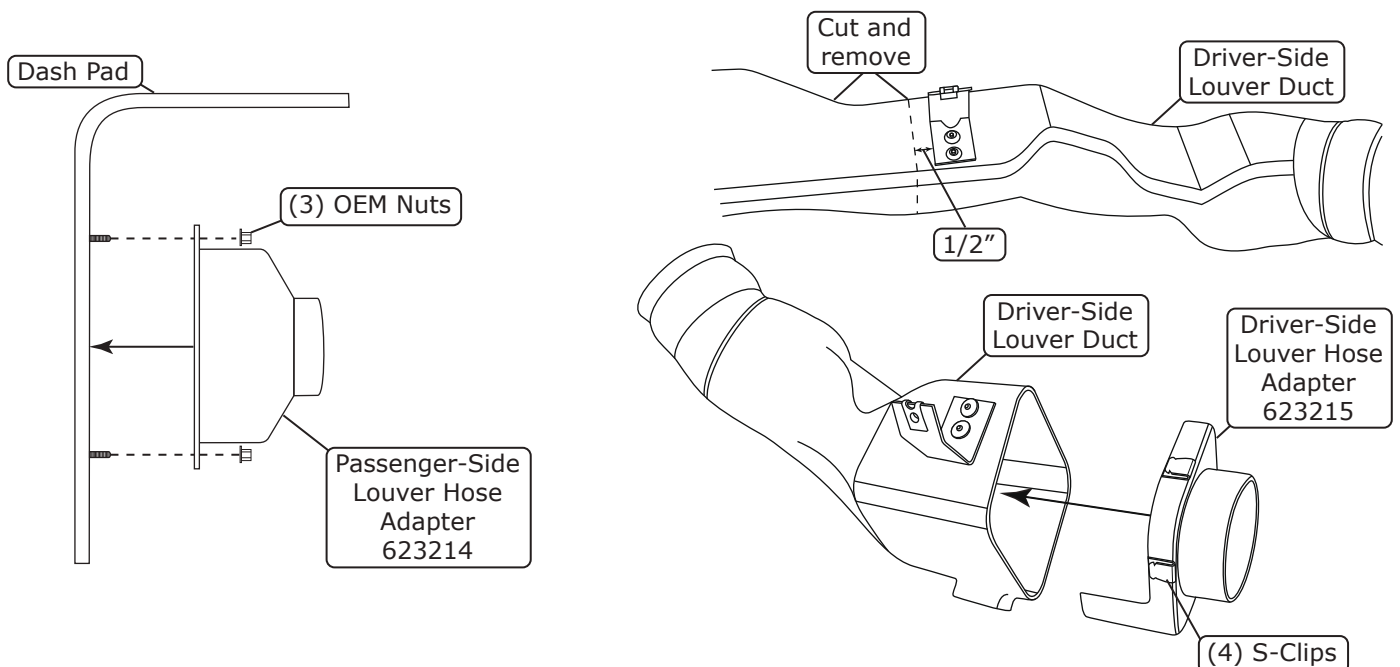



www.vintageair.com

## Final Steps: Completing the Install

1. Install duct hoses as shown in Figure 1, Page 19.
2. Route A/C wires (12 volt/grounds/binary switch/heater valve) through 3/8" grommet as shown in Figure 1, below.
3. Plug the wiring harnesses into the ECU module on the sub case as shown in Figure 1, Page 19. Wire according to wiring diagrams on Pages 20 and 21.
4. Install control panel assembly. Refer to control panel instructions.
5. Fill radiator with at least a 50/50 mixture of approved antifreeze and distilled water. It is the owner's responsibility to keep the freeze protection at the proper level for the climate in which the vehicle is operated. Failure to follow antifreeze recommendations will cause heater core to corrode prematurely and possibly burst in A/C mode and/or freezing weather, voiding your warranty.
6. Double check all fittings, brackets and belts for tightness.
7. Vintage Air recommends that all A/C systems be serviced by a licensed automotive A/C technician.
8. Evacuate the system for a minimum of 45 minutes prior to charging, and perform a leak check prior to servicing.
9. Charge the system to the capacities stated on Page 4 of this instruction manual.
10. If removed, reinstall the the right-inner fender.

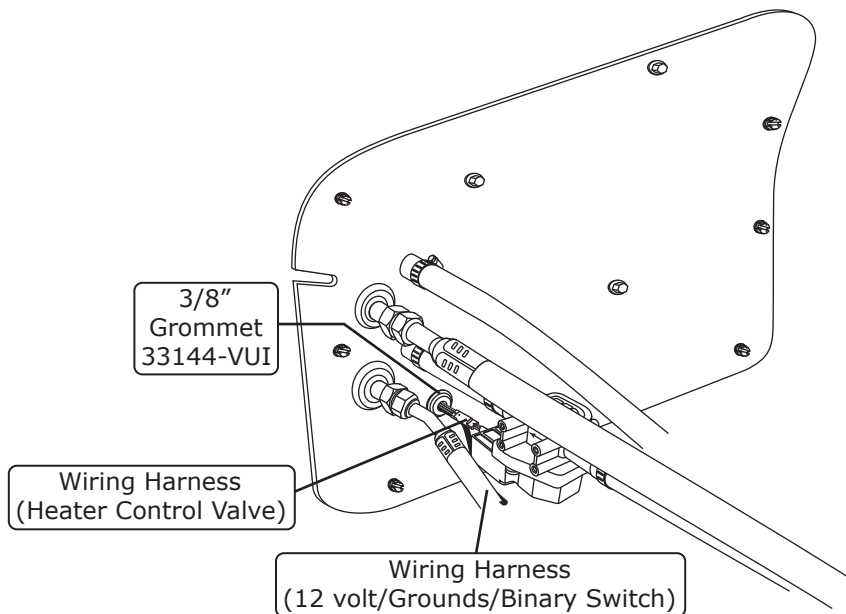



www.vintageair.com

# Final Steps: Installation Check

Installation Check	
ITEM TO CHECK	Procedure
<input type="checkbox"/>	<p>ECU</p> <p>If no blinking is observed after 1 minute of turning the ignition on, go to the next check.</p> <p>If repetitive blinking is observed, go to the <b>Advanced Diagnostics</b> Section to diagnose.</p>
<input type="checkbox"/>	<p>Blower speed control</p> <p>Set the blower speed control to <b>OFF</b>, <u>confirm that the blower is off</u>.</p> <p>Position the blower speed control to <b>LOW</b> then <b>MEDIUM</b> and then <b>HIGH</b>. <u>At each setting confirm that the blower speed increases</u>, do this by feeling for the amount of air coming from the unit and hearing the blower speed increase.</p>
<input type="checkbox"/>	<p>Mode control</p> <p>Set the <b>MODE</b> control to the <b>DASH</b> position. <u>Confirm that air is being blown at the dash vents</u>.</p> <p>Set the <b>MODE</b> control to the <b>FLOOR</b> position. <u>Confirm that air is being blown at the floor vents</u>.</p> <p>Set the <b>MODE</b> control to the <b>DEFROST</b> position. <u>Confirm that all air is being blown from the defrost vents</u></p> <p><u>If heater lines are installed:</u></p> <p>Set the <b>MODE</b> control to the <b>DASH</b> position. Set the <b>TEMP</b> control to the <b>MAX HEAT</b> position. <u>Confirm that HOT air is coming from the dash vents</u>.</p>
<input type="checkbox"/>	<p>Temperature control</p> <p><u>If system is charged:</u></p> <p>Set the <b>TEMP</b> control to the <b>MAX COOL</b> position. <u>Confirm that COLD air is coming from the dash vents</u>.</p> <p>Also <u>confirm that the compressor "clicks" on</u> when adjusting the <b>TEMP</b> control from the <b>MAX HEAT</b> position to the <b>MAX COOL</b> position.</p>
<input type="checkbox"/>	<p>AC Indicator (if applicable)</p> <p>While the <b>MODE</b> control is set to the <b>DASH</b> position, and the <b>TEMP</b> control is set to the <b>MAX COOL/MIN HEAT</b> position, <u>confirm that the blue AC Indicator light is on</u>.</p>
<input type="checkbox"/>	<p>Backlight (if applicable)</p> <p>If your control panel has backlight capabilities and has been wired, turn the dash lamp on and <u>confirm that the AC panel's legend is lit</u>.</p>
<input type="checkbox"/>	<p>Fittings</p> <p>Verify AC and Heater fittings are all tight.</p>



www.vintageair.com

# ECU, Control Panel & Duct Hose Routing

**NOTE:** For the system to function optimally, the duct hoses must be routed as directly as possible, taking care to avoid kinks, sharp bends and unnecessary length. Vintage Air supplies duct hoses in continuous lengths that will need to be cut to size depending on application. Before cutting, familiarize yourself with the installation instructions and verify the routing will work with your application. For custom hose routing, additional hose may be needed and can be purchased from Vintage Air.

1. Stretch the duct hose until there is no slack, measure, mark and cut hose to size (See Photo 1, below).

Stretch, measure, mark and cut hose to size



**Photo 1**

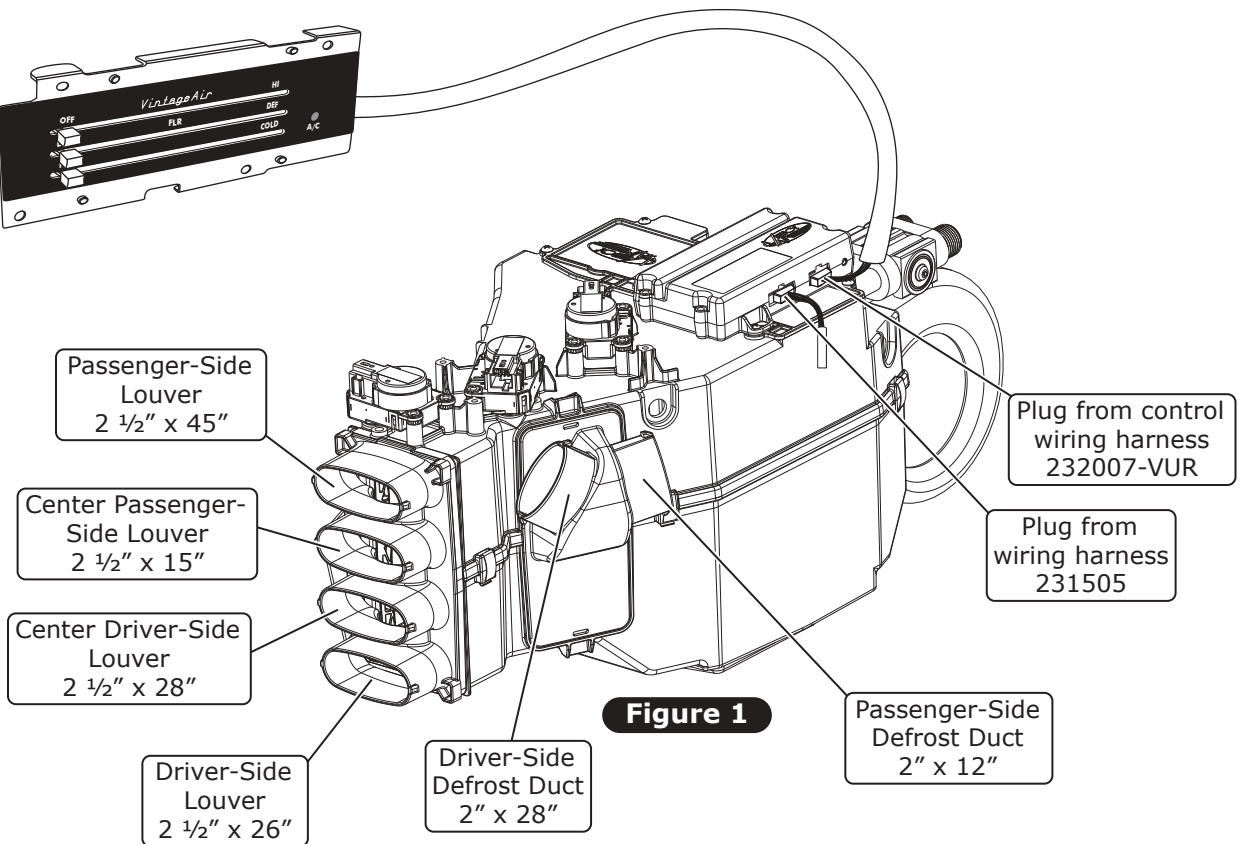
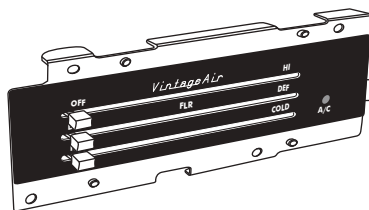

**NOTE:** ECU must be placed away from water and humidity, and also be accessible for servicing. If relocating, connectors must be positioned towards the bottom.

Position connectors towards bottom



www.vintageair.com

# Gen 5 Wiring Diagram

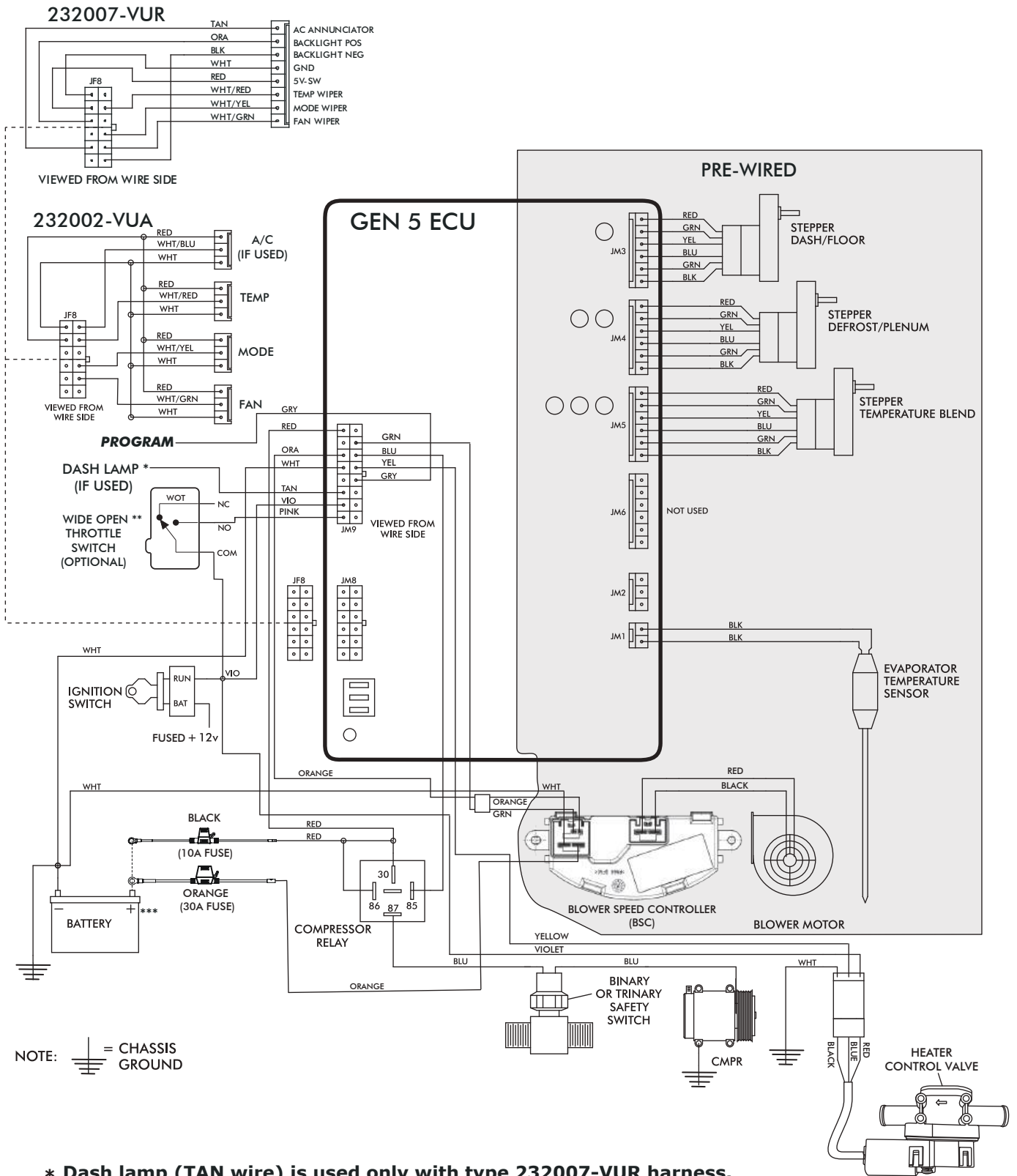

NOTE: = CHASSIS GROUND

- \* Dash lamp (TAN wire) is used only with type 232007-VUR harness.
- \*\* Wide open throttle switch contacts close only at full throttle, which disables A/C compressor.
- \*\*\* Install fuse assemblies at or as near to the battery as possible.



www.vintageair.com

# Gen 5 Wiring Instructions

WIRING HARNESS (231505) ↓

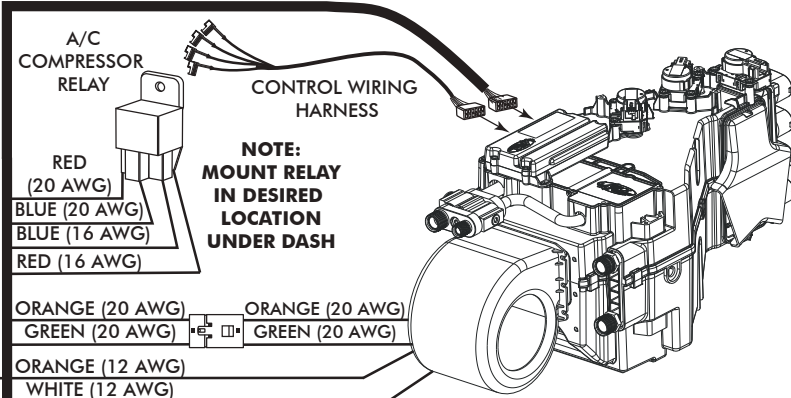

### Ignition Switch:

Using provided butt splice (PN 226004), connect the 20 AWG violet wire to a 5A fused and switched 12V source such as Key On.

### Wide Open Throttle Switch (Optional):

If a wide open throttle switch is required, connect the 20 AWG pink wire to a normally open switch that, when closed, connects a fused and switched 12V source to the pink wire. See Gen 5 wiring diagram for an example.

### Dash Light (Optional):

If using a Vintage Air control panel with back light, connect the 20 AWG tan wire to the vehicle's dash back light 0-12V using provided butt splice (PN 226004).

WIRING HARNESS (232020) →

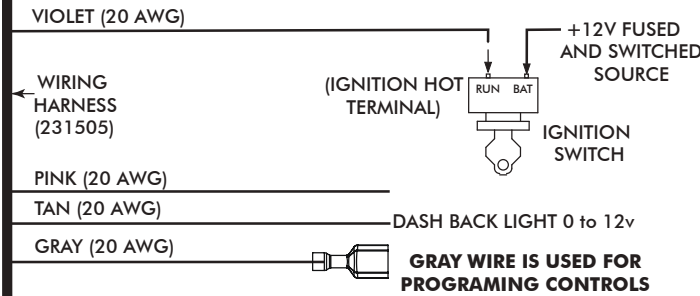

FIREWALL

FIREWALL

WIRING HARNESS (232020) →

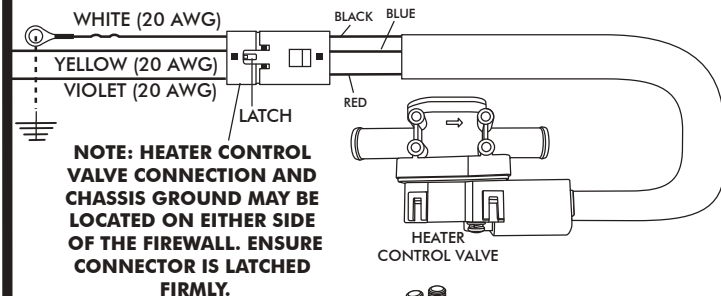

### Heater Control Valve:

Connect the Violet/Yellow/White twisted branch with 3 position connector into the heater control valve connector. Ensure that the mating latch is fully seated.

### Binary/Trinary & Compressor:

**Binary Switch:** Terminate provided insulated female terminal (PN 23172-VUW) to the blue 16 AWG wire. Connect as shown.  
**Trinary Switch:** Connect according to trinary switch wiring diagram.

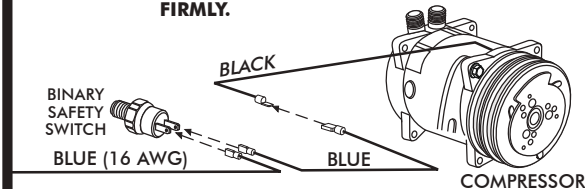

### Battery Connections:

**ECU Ground:** Terminate provided ring terminal (PN 226110) to 20 AWG white wire from the 231505 wire assembly and install at battery.  
**ECU PWR:** Terminate provided fuse assembly with black leads (PN 233012) to the 16 AWG red wire from the 231505 wire assembly. Install provided 10A Red Mini Fuse (PN 226118). Install at battery.  
**Blower Speed Controller (BSC) Ground:** Terminate provided ring terminal (PN 226111) to 12 AWG white wire from the 232020 wire assembly and install at battery.  
**Blower Speed Controller (BSC) PWR:** Terminate provided fuse assembly with orange leads (PN 233008) to the 12 AWG orange wire from the 232020 wire assembly. Install provided 30A Green ATO/ATC Fuse (PN 226125). Install at battery.

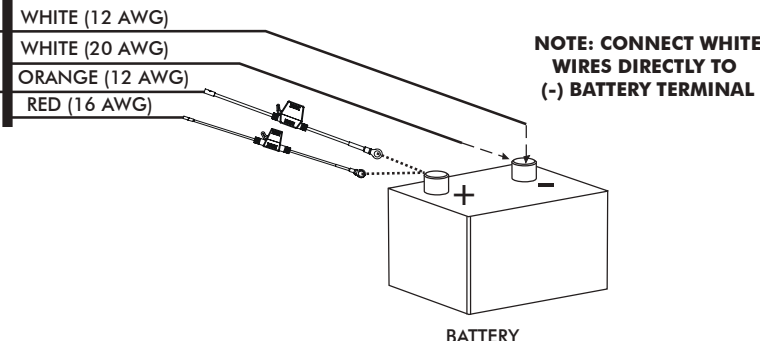



www.vintageair.com

## Glove Box Modification

1. Use the glove box modification template provided.
2. On the passenger side of the glove box, place the template onto the outside (See Photo 1, below). Mark the holes and the outside of the glove box using the top edge of the template (See Photo 1, below).
3. On the driver side of the glove box, place the template on the inside (See Photo 2, below). Mark the holes and the inside of the glove box using the top edge of the template (See Photo 2, below).
4. Cut the sides of the glove box.
5. Mark the bottom, connecting each cut side, then remove the front portion of the glove box (See Photos 3 and 4, below).
6. Drill the marked mounting holes using a 9/64" drill bit (See Photo 5, below).
7. Place the supplied glove box cap over the OEM glove box, then mark the mounting holes. Drill the glove box with the 9/64" drill bit.
8. Install the cap onto the glove box and secure using (4) black plastic rivets, (2) on each side (See Photos 6 and 7, below). **NOTE: Rivets may be separated for easier installation (See Photo 6, below).**

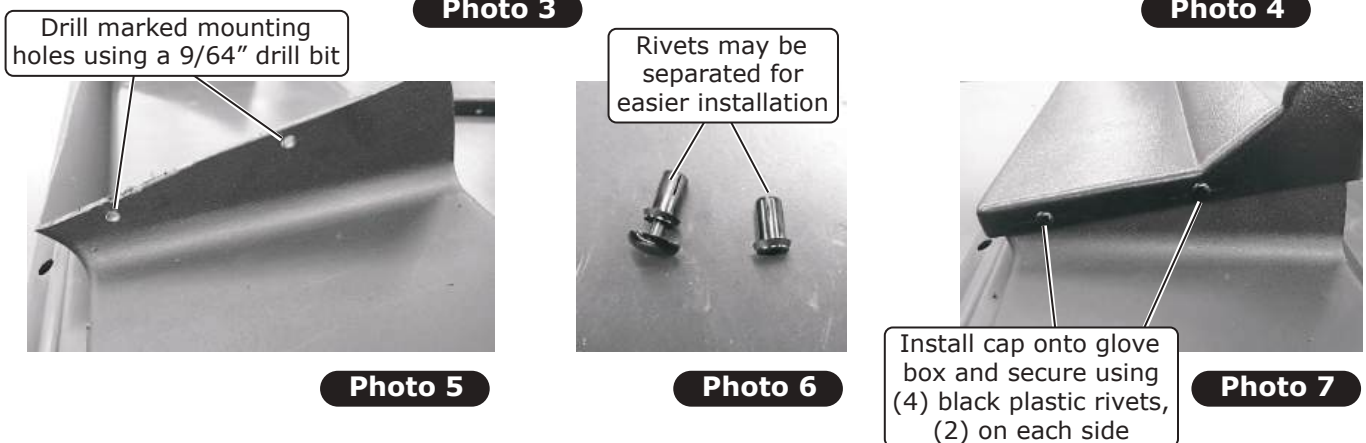
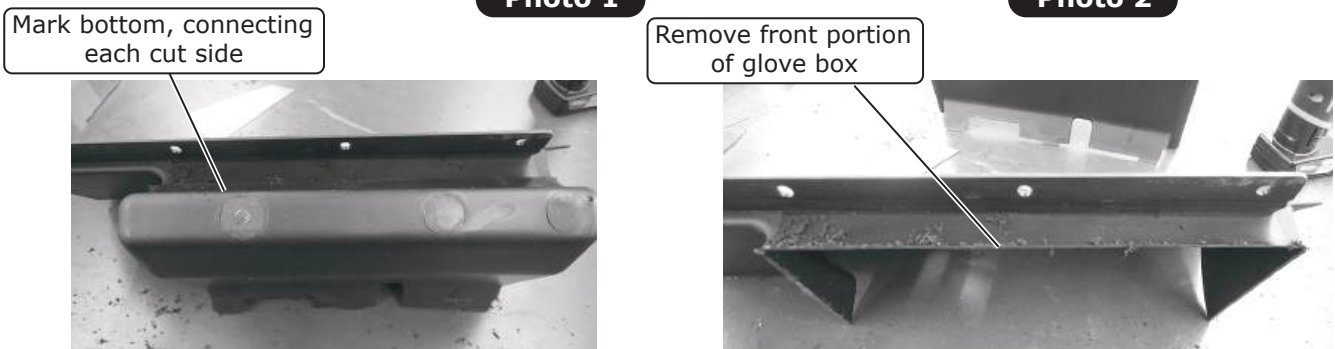
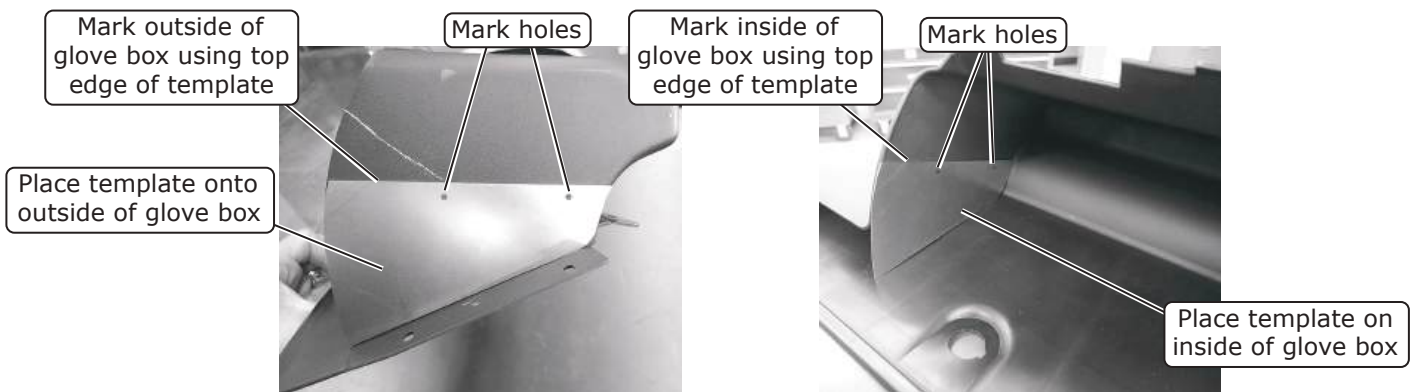



www.vintageair.com

# Quality Crimp Guideline

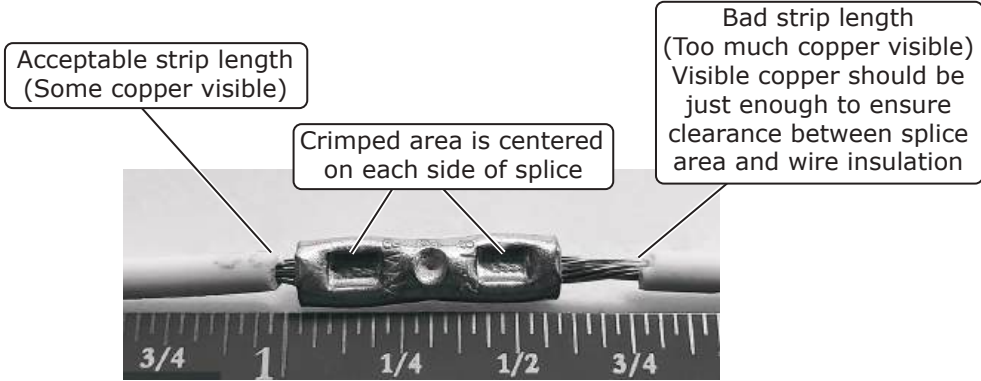

**Photo 1**

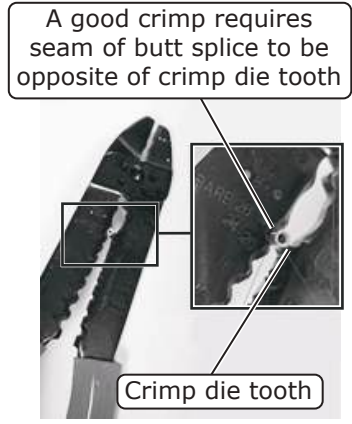

**Photo 2**

## Good Ring Terminal Crimp    Bad Ring Terminal Crimp



**Photo 3**

Crimp area is centered on barrel

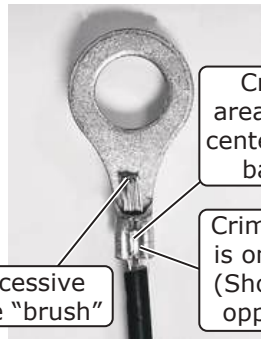

**Photo 4**



**Photo 5**

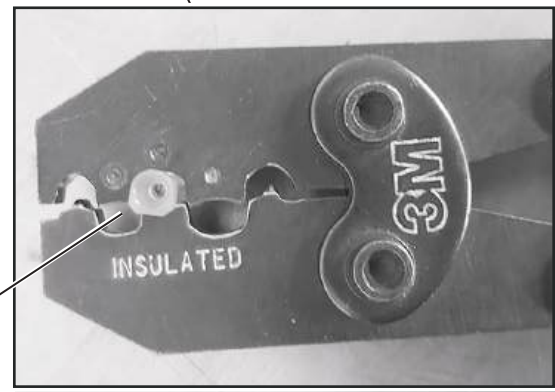

**Photo 5a**

Use a ratcheting crimp tool for insulated barrel terminals when crimping the provided female insulated terminal. Ensure terminal is inserted in appropriate position before crimping.



www.vintageair.com

## Operation of Controls

On Gen IV or Gen 5 systems with three lever/knob controls, the temperature control toggles between heat and A/C operations. To activate A/C, move the temperature lever/knob all the way to cold and then back it off to the desired vent temperature. For heat operation, move the temperature lever/knob all the way to hot and then adjust to the desired vent temperature. The blower will momentarily change speed, each time you toggle in and out of heat and A/C operations, to indicate the change.

### Blower Speed

This lever/knob controls blower speed, from OFF to HI.

### Mode Control

This lever/knob controls the mode positions, from DASH to FLOOR to DEFROST, with a blend in between.

### Temperature Control

This lever/knob controls the temperature, from HOT to COLD.

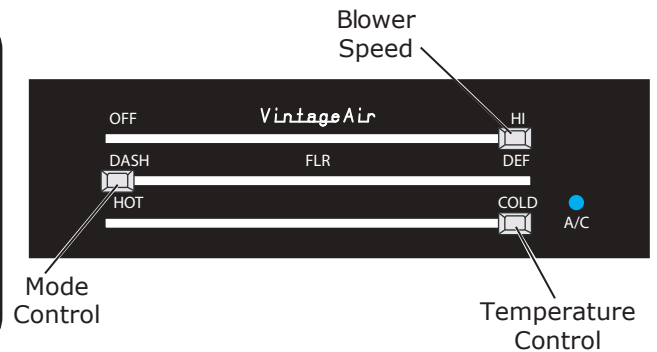

## A/C Operation

### Blower Speed

Adjust to desired speed.

### Mode Control

Adjust to desired mode position (DASH position recommended).

### Temperature Control

For A/C operation, adjust to coldest position to engage compressor (adjust between HOT and COLD to reach desired temperature).



## Heat Operation

### Blower Speed

Adjust to desired speed.

### Mode Control

Adjust to desired mode position (FLOOR position recommended).

### Temperature Control

For maximum heating, adjust to hottest position (adjust between HOT and COLD to reach desired temperature).



## Defrost/De-fog Operation

### Blower Speed

Adjust to desired speed.

### Temperature Control

Adjust to desired temperature.

### Mode Control

Adjust to DEFROST position for maximum defrost, or between FLOOR and DEFROST positions for a bi-level blend (Compressor is automatically engaged).





www.vintageair.com

# Troubleshooting Guide

This printed troubleshooting guide is our basic guide that covers common installation problems. To see our advanced diagnostics and troubleshooting guide, please refer to the following page for instructions on how to download the complete guide.

**WARNING: While troubleshooting the system, never probe connector terminals from the front mating side, only back probe.**  
**WARNING: While troubleshooting the system, never use automotive check lights.**

Symptom	Condition	Checks	Actions	Notes
1. Blower stays on high speed with ignition on.	No other functions work.	Check for damaged pins or wires in the control panel wire assembly and mating header at ECU.	If found damaged, replace wire assembly or ECU.	If fuse continues to blow, there is a serious problem in the wiring. Check all wiring and ensure the wire is not damaged and shorting out along its route.
	All other functions work.	Check for a bad ECU GND. Check for damaged pins or wires in the control panel wire assembly and mating header at ECU. Check if Blower power fuse is blown. Check for a bad ECU GND.	If found damaged, replace wire assembly or ECU. Replace fuse. Repair connection.	
2. Compressor will not turn on (All other functions work).	System is not charged.	System must be charged for compressor to engage.	Charge system.	<b>Danger: Never bypass safety switch with engine running. Serious injury can result.</b>  To check for proper pot function, check voltage at white/red wire. Voltage should be between 0V and 5V, and will vary with pot lever position.
		Check for faulty A/C potentiometer or associated wiring (not applicable to 3-pot controls).	Check continuity to ground on white control head wire. Check for 5V on red control head wire.	
	System is charged.	Check for disconnected or faulty thermistor.	Check 2-pin connector at ECU housing.	Disconnected or faulty thermistor will cause compressor to be disabled.
3. Compressor will not turn off (All other functions work).	Compressor will not turn off (All other functions work).	Check for faulty A/C potentiometer or associated wiring.	Repair or replace pot/control wiring.	Red wire at A/C pot should have approximately 5V with ignition on. White wire will have continuity to chassis ground. White/Red wire should vary between 0V and 5V when lever is moved up or down.
		Check for faulty A/C relay.	Replace relay.	



www.vintageair.com

# Troubleshooting Guide (Cont.)

Symptom	Condition	Checks	Actions	Notes
4. System will not turn on, or runs intermittently.	Works when engine is not running; shuts off when engine is started	Noise interference from either ignition or alternator.	Install capacitors on ignition coil and alternator. Ensure good ground at all points. Relocate coil and associated wiring away from ECU and ECU wiring. Check for burned or loose plug wires.	Ignition noise (radiated or conducted) will cause the system to shut down due to high voltage spikes. If this is suspected, check with a quality oscilloscope. Spikes greater than 16V will shut down the ECU. Install a radio capacitor at the positive post of the ignition coil (see radio capacitor installation bulletin). A faulty alternator or worn out battery can also result in this condition.
	Will not turn on under any conditions.	Verify connections on power lead, ignition lead, and both white ground wires.	Check for power at ECU, and confirm ignition is being applied to ECU properly.	
		Verify battery voltage is greater than 10 volts and less than 16 while engine is running.	Verify proper meter function by checking the condition of a known good battery.	
5. Loss of mode door function.	No mode change at all.	Check for damaged mode switch or potentiometer and associated wiring.		
6. Blower turns on and off rapidly.	Battery voltage is at least 12V.	Check for at least 12V at circuit breaker.	Ensure all system grounds and power connections are clean and tight.	System shuts off blower at 10V. Poor connections or weak battery can cause shutdown at up to 11V.
	Battery voltage is less than 12V.	Check for faulty battery or alternator.	Charge battery.	
7. Erratic functions of blower, mode, temp, etc.		Check for damaged switch or pot and associated wiring.	Repair or replace.	

## Advanced Diagnostics and Troubleshooting Guide

If after referencing the Troubleshooting Guide, the issue is not resolved, move to The Advanced Diagnostics and Troubleshooting Guide that covers the following:

- **ECU Diagnostics Codes**
  1. **ECU Blink Sequence**
  2. **Firmware Version Number**
  3. **ECU Model Number**
  4. **ECU Start-Up Blink Sequence**
  5. **Diagnostic Codes**
- **Complete Advanced Troubleshooting Guidelines**

Access the latest version of the Advanced Diagnostics and Troubleshooting Guide by scanning the following QR code on your mobile device:



You can also access the guide by typing the following address into your web browser:

[https://www.vintageair.com/instructions\\_pdf/905000.pdf](https://www.vintageair.com/instructions_pdf/905000.pdf)



www.vintageair.com

# Power Steering Bracket Modification

**NOTE: Use the illustrations below to determine power steering bracket, version 1 or 2.**

1. Cut along the dashed lines, then align the template hole and adjustment slot with the hole and adjustment slot on the power steering bracket.
2. Mark the bracket around the perimeter of the template.
3. Cut and remove the shaded portion of the power steering bracket as shown below.
4. Discard the A/C compressor mounting portion of the bracket.
5. Reinstall the power steering bracket onto the power steering pump.

VERSION 1

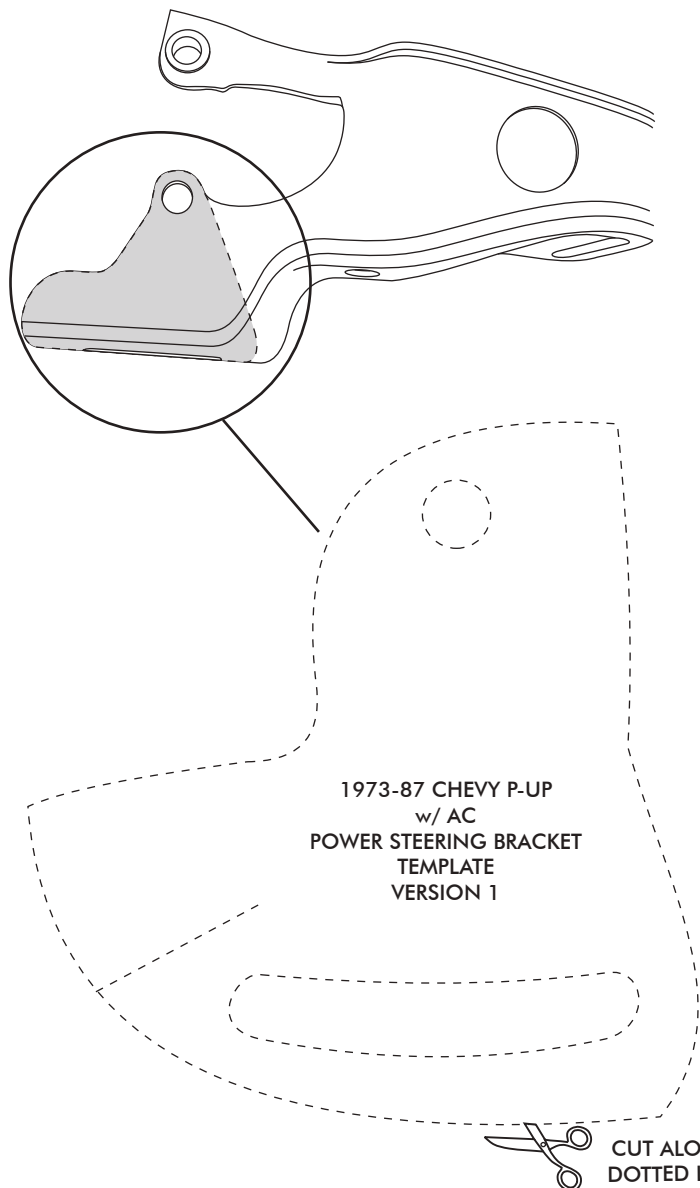

VERSION 2

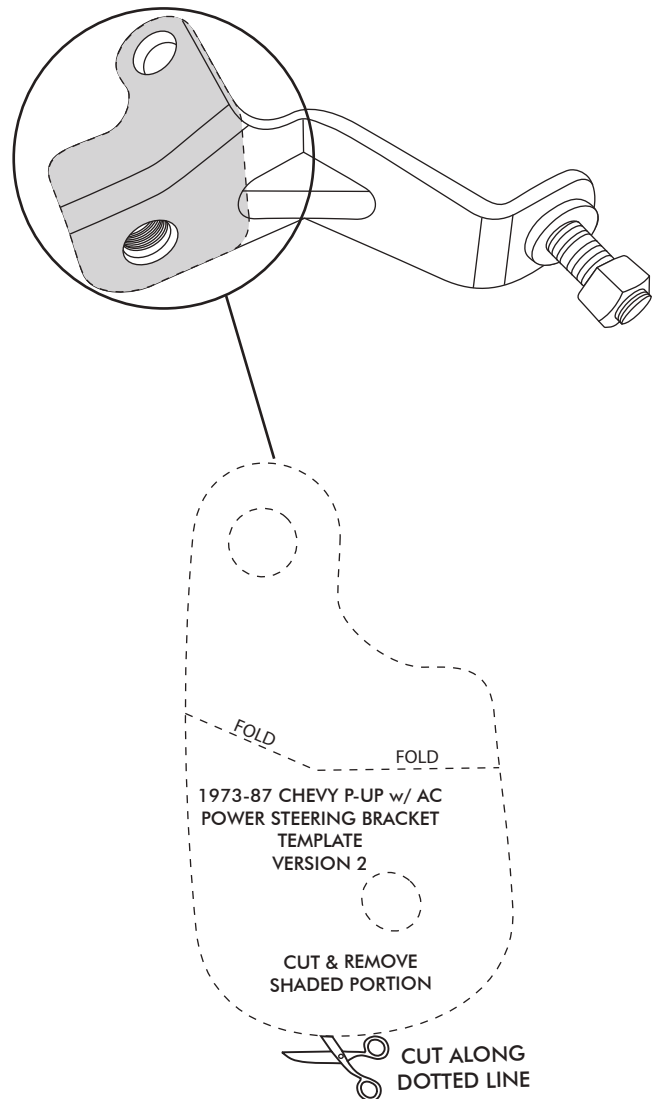

**NOTE: Due to printing variances, measure the line below before using this template. If template is scaled properly, the line should measure 6 inches.**









www.vintageair.com

# Packing List: Evaporator Kit (755621)

No.	Qty.	Part No.	Description
1.	1	765200	Gen 5 Super Magnum Module
2.	1	795621	Accessory Kit

Checked By: \_\_\_\_\_  
 Packed By: \_\_\_\_\_  
 Date: \_\_\_\_\_

1

**Gen 5 Super Magnum  
Module  
765200**

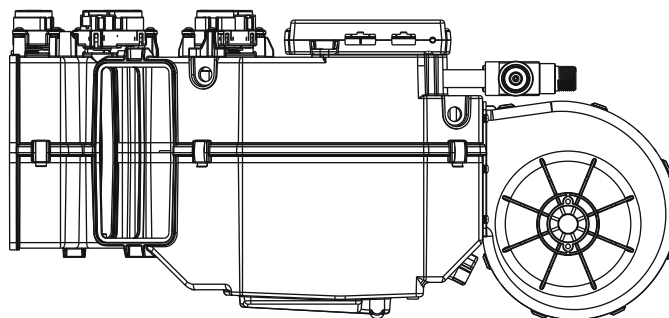

2

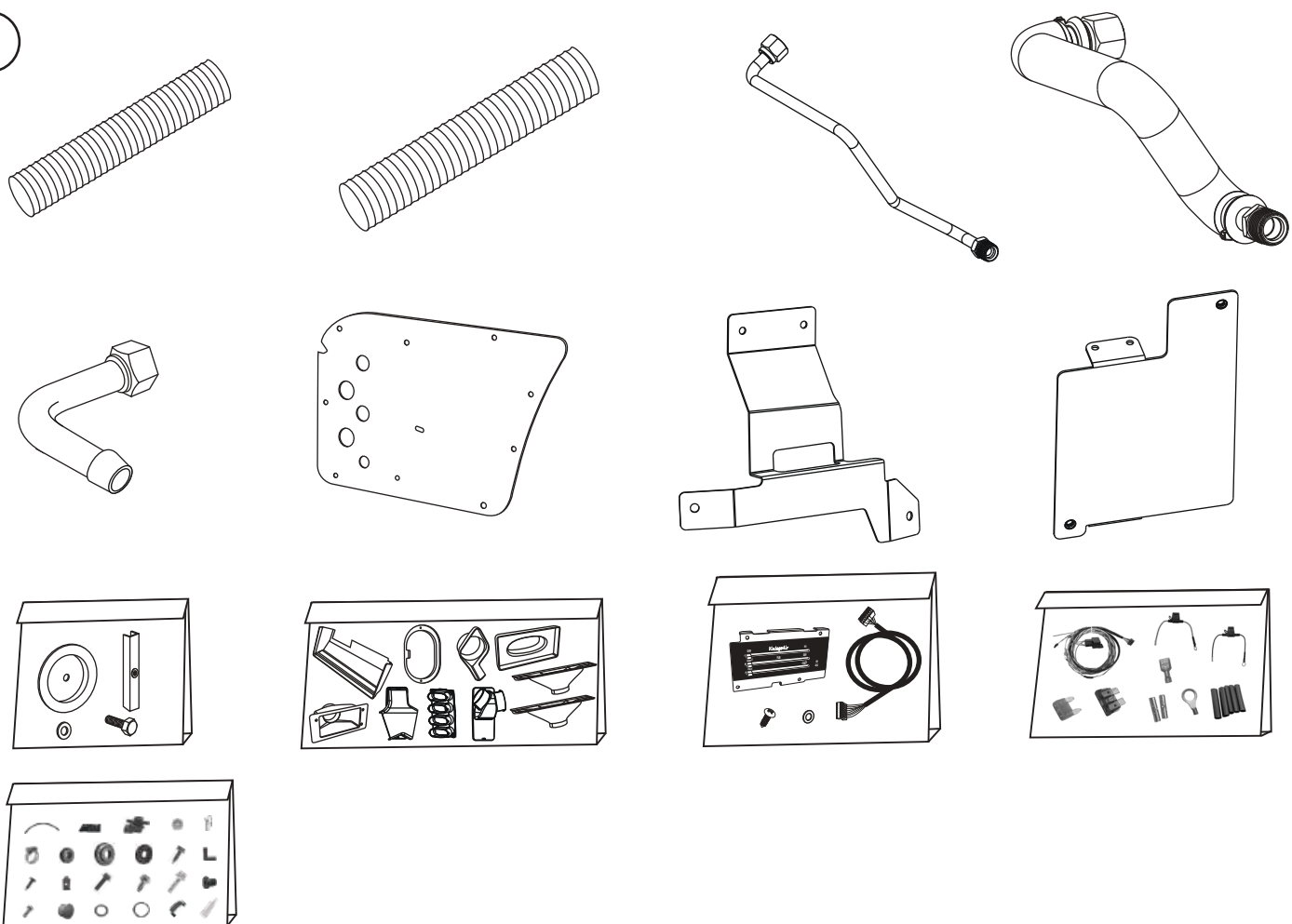

**Accessory Kit  
795621**

**NOTE: Images may not depict actual parts and quantities.  
Refer to packing list for actual parts and quantities.**