



1969-70 Ford Mustang

without Factory Air
Gen 5 Evaporator Kit
(551967)



18865 Goll St. San Antonio, TX 78266
Phone: 800-862-6658
Sales: sales@vintageair.com
Tech Support: tech@vintageair.com
www.vintageair.com



www.vintageair.com

Table of Contents

Cover.....	1
Table of Contents.....	2
Packing List/Parts Disclaimer.....	3
Information Page.....	4
Wiring Notice.....	5
Engine Compartment Disassembly, Condenser Assembly and Installation, Compressor and Brackets, Passenger Compartment Disassembly.....	6
Firewall Modification and Insulation.....	7
Firewall Modification and Insulation (Cont.).....	8
Defrost Duct and Fresh Air Cap Installation, Lubricating O-rings.....	9
Properly Seated O-ring Land, Evaporator Preparation.....	10
Evaporator Preparation (Cont.).....	11-13
Evaporator Preparation (Final), Evaporator Installation (Passenger Compartment).....	14
Firewall Cover Preparation & Installation, Passenger Compartment Wiring.....	15
Passenger Compartment Wiring (Cont.), Driver- and Passenger-Side Louver Installation.....	16
Center Louver Installation (Option 1), Center Louver Installation (Option 2).....	17
Drain Hose Installation.....	18
A/C Hose Installation.....	19
Heater Hose & Heater Control Valve Installation.....	20
Driver Side A/C and Heater Hose Routing.....	21
Engine Compartment Wiring.....	22
Final Steps: Installation Check.....	23
Final Steps: Completing the Install.....	24
Duct Hose Routing.....	25
Quality Crimp Guideline.....	26
Gen 5 Wiring Diagram.....	27
Gen 5 Wiring Connection Instruction.....	28
Operation of Controls.....	29
Troubleshooting Guide.....	30
Troubleshooting Guide (Cont.), Advanced Diagnostics and Troubleshooting Guide.....	31
Driver-Side Louver Template.....	32
Passenger-Side Louver Template.....	33
Center Louver Template.....	34
Firewall Cover Hole Template.....	35
Packing List.....	36



www.vintageair.com

Packing List: Evaporator Kit (551967)

No.	Qty.	Part No.	Description
1.	1	765200	Gen 5 Magnum Max Module with 404 ECU
2.	1	781967	Accessory Kit

**** Before beginning installation, open all packages and check contents of shipment. Please report any shortages directly to Vintage Air within 15 days. After 15 days, Vintage Air will not be responsible for missing or damaged items.**

1



Gen 5 Magnum Max
Module with 404 ECU
765200

2

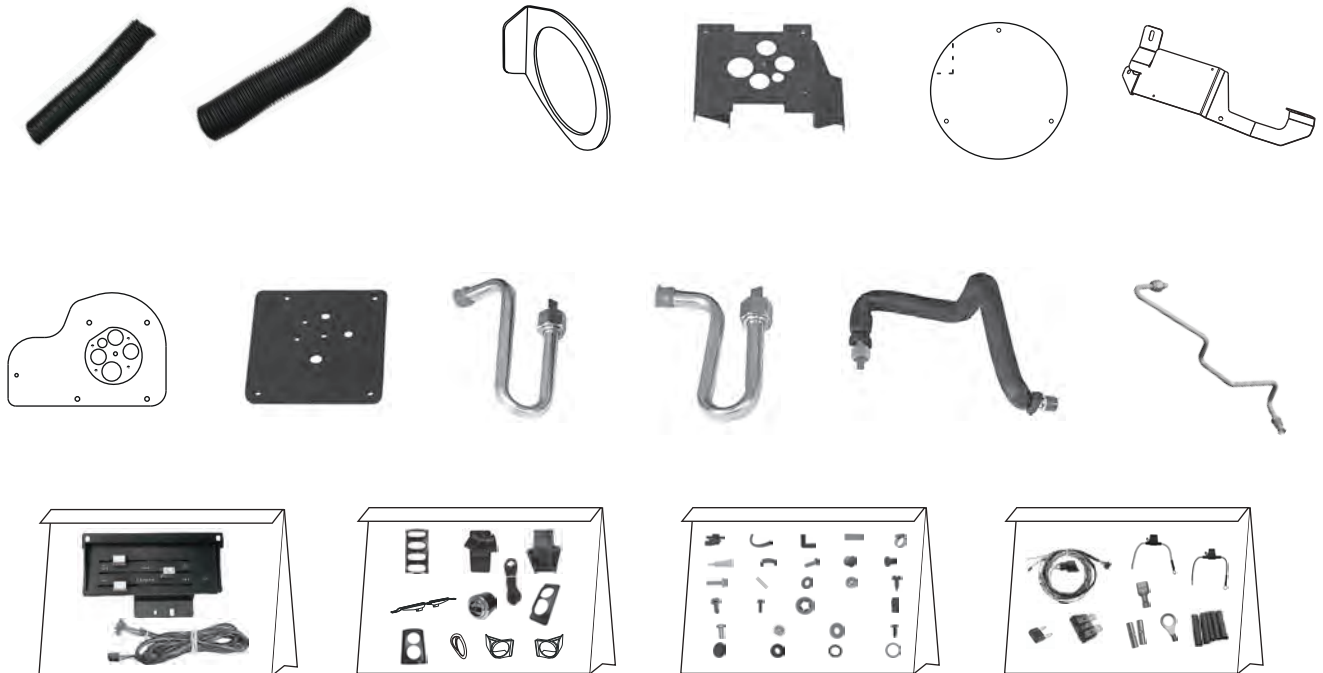

Accessory Kit
781967

NOTE: Images may not depict actual parts and quantities. Refer to packing list for actual parts and quantities.



www.vintageair.com

Important Notice—Please Read

For Maximum System Performance, Vintage Air Recommends the Following:

NOTE: Vintage Air systems are designed to operate with R134a refrigerant only. Use of any other refrigerant could damage your A/C system and/or vehicle, and possibly cause a fire, in addition to potentially voiding the warranties of the A/C system and its components.

Refrigerant Capacities:

Vintage Air System: 1.8 lbs. (28.8 oz.) or 816 grams of **R134a**, charged by weight with a quality charging station or scale. **NOTE: Use of the proper type and amount of refrigerant is critical to system operation and performance.**

Other Systems: Consult manufacturer's guidelines.

Lubricant Capacities:

New Vintage Air-Supplied Sanden Compressor: No additional oil needed (Compressor is shipped with proper oil charge).

All Other Compressors: Consult manufacturer (Some compressors are shipped dry and will need oil added).

Safety Switches

Your Vintage Air system is equipped with a binary pressure safety switch. A binary switch disengages the compressor clutch in cases of extreme low pressure conditions (refrigerant loss) or excessively high head pressure (406 PSI) to prevent compressor damage or hose rupture. A trinary switch combines Hi/Lo pressure protection with an electric fan operation signal at 254 PSI, and should be substituted for use with electric fans. Compressor safety switches are extremely important since an A/C system relies on refrigerant to circulate lubricant.

Service Info:

Protect Your Investment: Prior to assembly, it is critical that the compressor, evaporator, A/C hoses and fittings, hardlines, condenser and receiver/drier remain capped. Removing caps prior to assembly will allow moisture, insects and debris into the components, possibly leading to reduced performance and/or premature failure of your A/C system. This is especially important with the receiver/drier.

Additionally, when caps are removed for assembly, **BE CAREFUL!** Some components are shipped under pressure with dry nitrogen.

Evacuate the System for 35-45 Minutes: Ensure that system components (Drier, compressor, evaporator and condenser) are at a temperature of at least 85°F. On a cool day, the components can be heated with a heat gun **or** by running the engine with the heater on before evacuating. Leak check and charge to specifications.

Bolts Passing Through Cowl and/or Firewall:

To ensure a watertight seal between the passenger compartment and the vehicle exterior, for all bolts passing through the cowl and/or firewall, Vintage Air recommends coating the threads with silicone prior to installation.

Heater Hose (not included with this kit):

Heater hose may be purchased from Vintage Air (Part#31800-VUD) or your local parts retailer. Routing and required length will vary based on installer preference.



www.vintageair.com

Important Wiring Notice—Please Read

Some vehicles may have had some or all of their radio interference capacitors removed. There should be a capacitor found at each of the following locations:

- 1. On the positive terminal of the ignition coil.**
- 2. If there is a generator, on the armature terminal of the generator.**
- 3. If there is a generator, on the battery terminal of the voltage regulator.**

Most alternators have a capacitor installed internally to eliminate what is called “whining” as the engine is revved. If whining is heard in the radio, or just to be extra cautious, a radio interference capacitor can be added to the battery terminal of the alternator.

It is also important that the battery lead is in good shape and that the ground leads are not compromised. There should be a heavy ground from the battery to the engine block, and additional grounds to the body and chassis.

If these precautions are not observed, it is possible for voltage spikes to be present on the battery leads. These spikes come from ignition systems and charging systems, and from switching some of the vehicle’s other systems on and off. Modern computer-operated equipment can be sensitive to voltage spikes on the power leads, which can cause unexpected resets, strange behavior and/or permanent damage.

Vintage Air strives to harden our products against these types of electrical noise, but there is a point where a vehicle’s electrical system can be degraded so much that nothing can help.

Radio interference capacitors should be available at most auto and truck parts suppliers. They typically are cylindrical in shape, a little over an inch long and a little over a half-inch in diameter, and they have a single lead coming from one end of the cylinder with a terminal on the end of the wire, as well as a mounting clip which is screwed into a good ground on the vehicle. The specific value of the capacitance is not too significant in comparison to ignition capacitors that are matched with the coil to reduce pitting of the points.

- Care must be taken, when installing the compressor lead, not to short it to ground. The compressor lead must not be connected to a condenser fan or to any other auxiliary device. Shorting to ground or connecting to a condenser fan or any other auxiliary device may damage wiring or the compressor relay, and/or cause a malfunction.
- When installing ground leads on Gen 5 systems, the blower control ground and ECU ground must be connected directly to the negative battery post.
- For proper system operation, the heater control valve must be connected to the ECU.



www.vintageair.com

Engine Compartment Disassembly

NOTE: Before starting the installation, check the function of the vehicle (horn, lights, etc.) for proper operation, and study the instructions, illustrations, & diagrams.

Perform the following:

1. Disconnect the battery.
2. Remove the battery and battery tray (retain).
3. Drain the radiator.
4. Remove the OEM heater hoses (discard).

Condenser Assembly and Installation

1. Refer to separate instructions included with the condenser kit to install the condenser.
2. Binary switch installation (Refer to condenser instructions).

Compressor and Brackets

1. Refer to separate instructions included with the bracket kit to install the compressor bracket.

Passenger Compartment Disassembly

NOTE: Removal of the dashboard is required to install the evaporator. Vintage Air recommends utilizing the factory service manual when disassembling and reassembling the dashboard.

Perform the following:

1. Remove the dash pad, instrument panel, passenger side panel and lower passenger side dashboard (retain screws) (See Figure 1, below).
2. Remove the glove box (discard) (See Figure 1, below). **NOTE: The glove box will not fit with the evaporator unit installed. A with factory air vehicle aftermarket glove box will need to be purchased.**
3. Remove the heater assembly and all related ducting (discard) (retain screws) (See Figure 2, below). Remove the control panel assembly (retain control panel) (See Figure 1, below). **NOTE: Refer to the control panel conversion kit instructions for installation of the controls.**
4. Remove the OEM defrost duct assembly (See Figure 2, below).

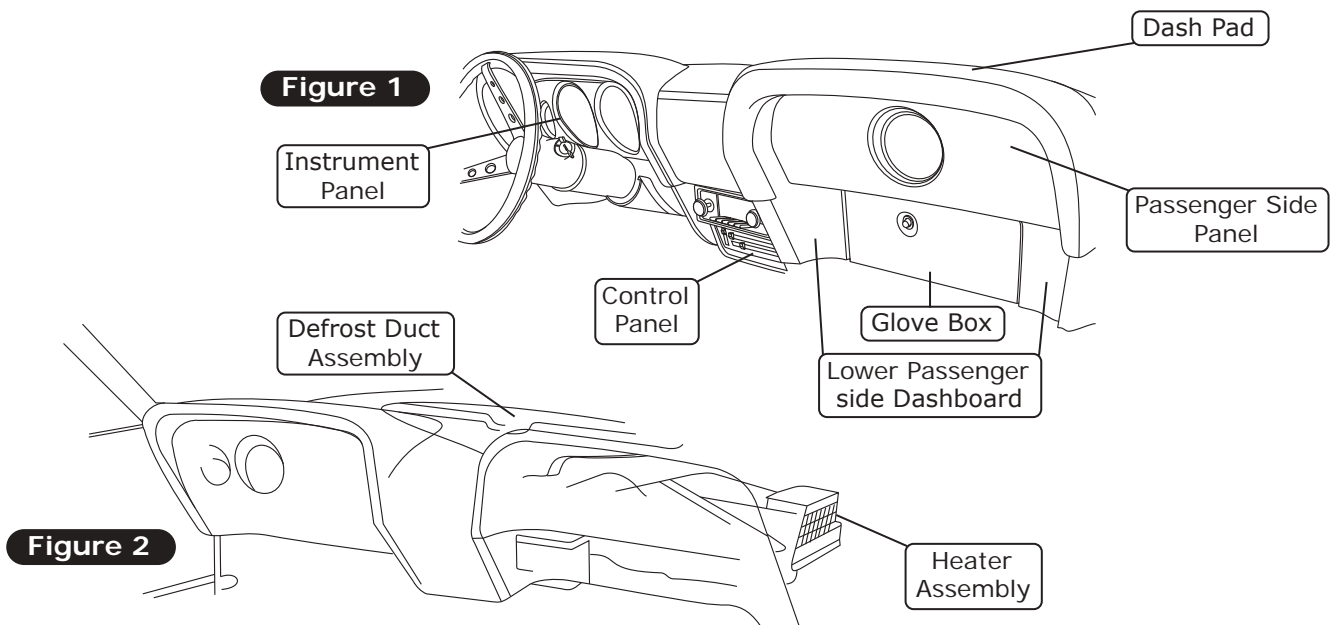



www.vintageair.com

Firewall Modification and Insulation

NOTE: The firewall requires modification for the drain hose to be installed. For proper system operation, Vintage Air recommends using heat-blocking insulation in the area around the evaporator module (firewall, kick panel, inner cowl, firewall covers). Due to tight clearance for the evaporator module between the firewall and dash, Vintage Air recommends an insulation thickness of no more than 1/4". Vintage Air recommends using Dynaliner #461501-VIP. To ensure a watertight seal between the passenger compartment and the vehicle exterior, for all bolts passing through the firewall, Vintage Air recommends coating the threads with silicone prior to installation.

1. Remove the OEM evaporator bracket (if equipped) from the cowl (See Photo 1, below). **NOTE: this bracket is not needed, and will interfere with the installation.**
2. Locate the Firewall Cover Hole Template on Page 35, and match up the factory holes as shown in Photo 2, below.

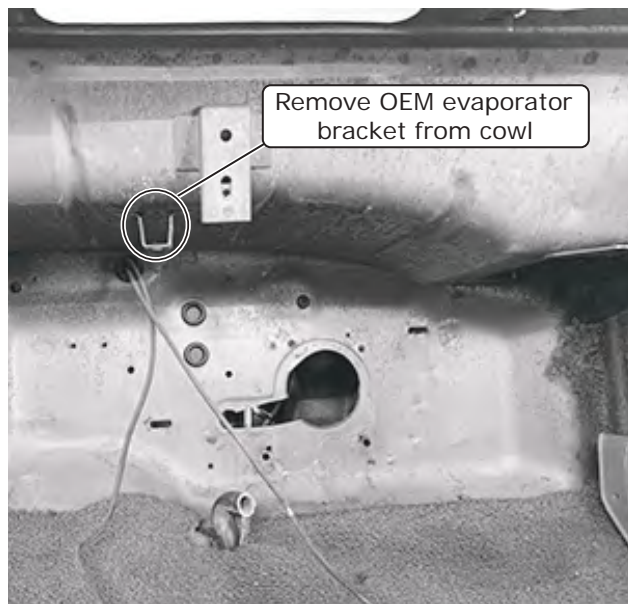

Photo 1

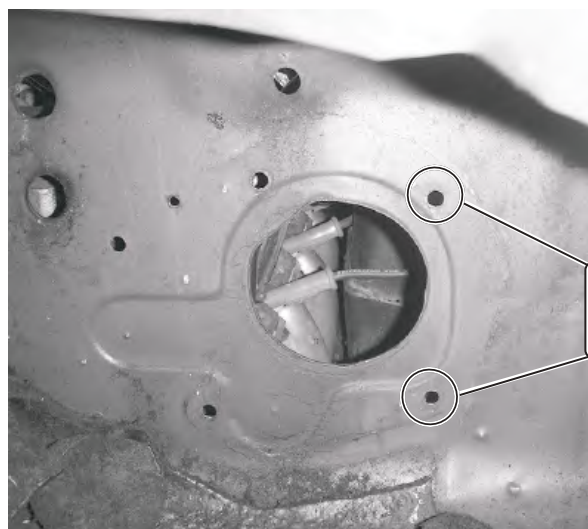

Photo 2



www.vintageair.com

Firewall Modification and Insulation (Cont.)

3. Using the firewall cover hole template, mark and drill the mounting holes into the firewall using a 17/64" drillbit.
4. Install (3) 1 1/4" grommets into the firewall openings (See Photo 3, below). **NOTE: Apply silicone/sealer if needed.**
5. Locate the OEM heater box firewall washers, (2) 1/4-20 x 3/4" black serrated flange bolts and (2) 1/4" pushnut bolt retainers.
6. Install the bolts and retainers onto the OEM evaporator firewall washers as shown in Photos 4 and 5, below. Apply sealer (See Photo 6, below), then install them into the firewall in the OEM locations (See Photos 7 and 8, below). Secure them using (2) washers and (2) 1/4-20 nuts with star washers (See Photos 7 and 8, below).
7. Apply insulation at this time (See Photo 9, below). **NOTE: Cut out openings for hardlines and hardware (See Photo 9, below).**

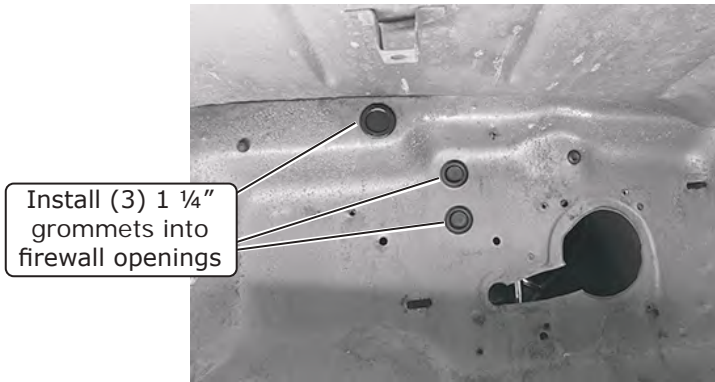

Photo 3



Photo 4

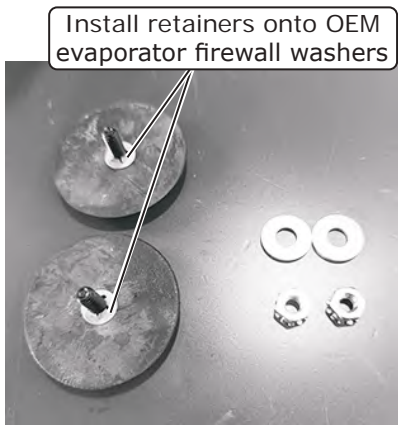

Photo 5

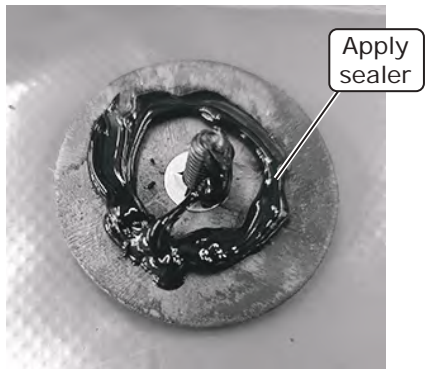

Photo 6

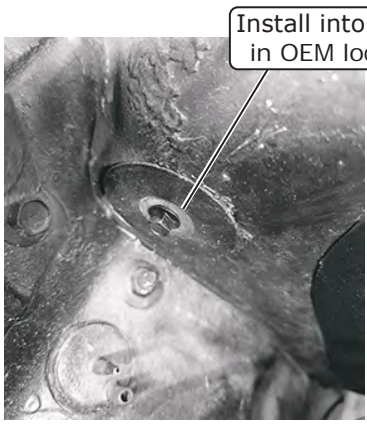

Photo 7

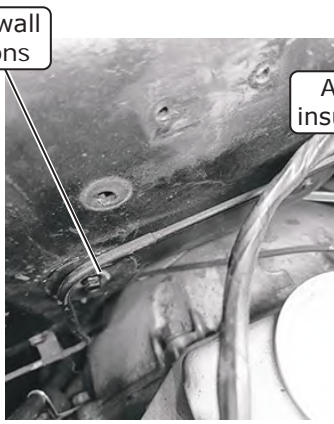

Photo 8

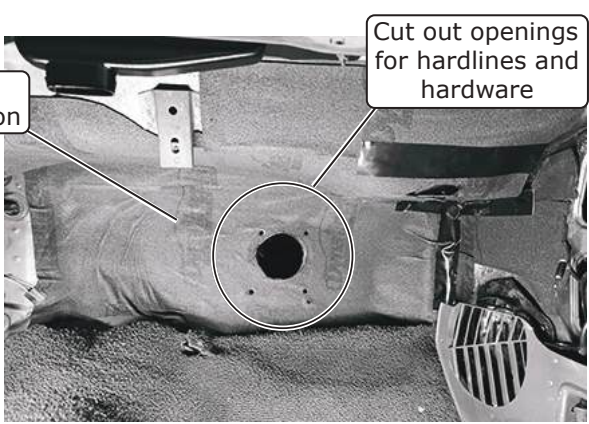

Photo 9



www.vintageair.com

Defrost Duct and Fresh Air Cap Installation

1. Install the defrost duct under the dash as shown in Figure 1, below. Secure it using the OEM nuts with (3) 3/16" flat washers.
2. Hold the fresh air cap under the dash and mark the (3) mounting holes.
3. Drill (3) 1/8" mounting holes under the dash.
4. Apply a 1/4" bead of silicone around the back side of the fresh air cap as shown in Figure 1, below.
5. Secure the fresh air cap to the fresh air hole using (3) #10 x 1/2" sheet metal screws as shown in Figure 1, below.

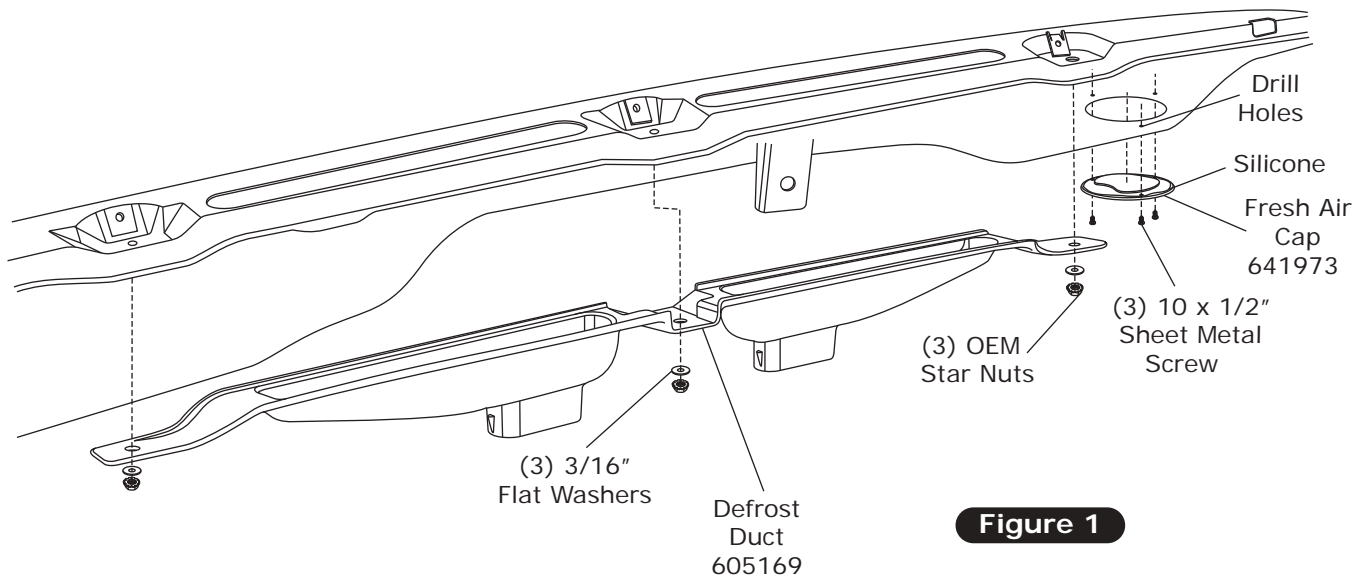
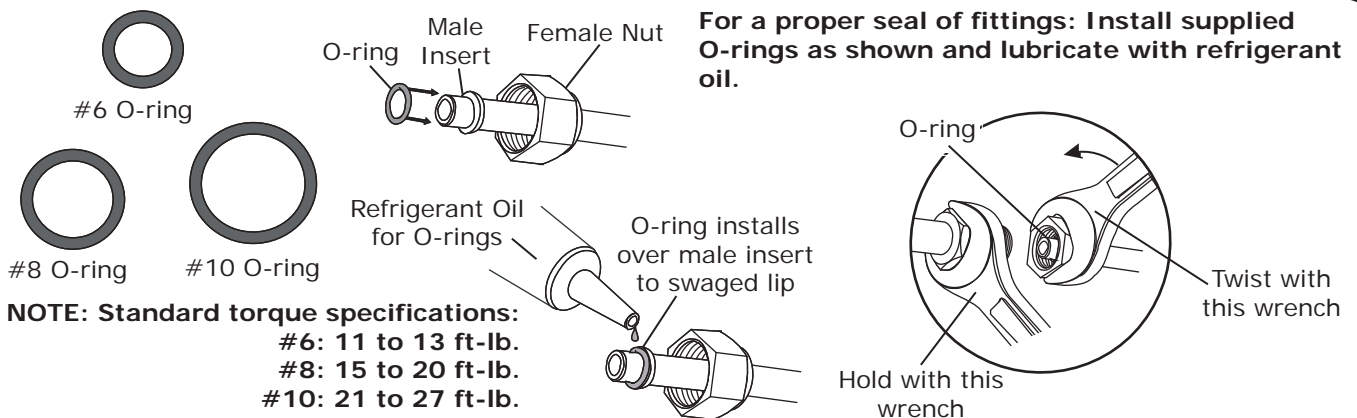

Figure 1

Lubricating O-rings





www.vintageair.com

Properly Seated O-ring Land

When installing a hardline or A/C hose fitting onto the evaporator module, ensure the O-ring land is seated properly (See Photo 1, below). An improperly seated O-ring land (See Photo 2, below) can cause a leak. To properly install the fitting, slide the hardline or A/C hose nut back to expose the O-ring land and seat it onto the evaporator module fitting. Then, slide the hardline or A/C hose nut forward and thread it onto the evaporator module fitting, ensuring the O-ring land does not move or lift.

Properly Seated O-ring Land



Photo 1

Improperly Seated O-ring Land



Photo 2

NOTE: Photos shown are for reference only. Fittings may vary depending on kit received.

Evaporator Preparation

Perform the following on a workbench:

1. Install (3) 1/2" plastic plugs into the back of the evaporator module (See Photos 1, 2, 3 and 4, below).
2. With a properly lubricated #6 O-ring (See Lubricating O-rings, Page 9), loosely install the #6 liquid hardline onto the #6 fitting on the block valve adapter (See Photo 5, below).
3. With a properly lubricated #10 O-ring (See Lubricating O-rings, Page 9), loosely install the lower heater hardline onto the lower heater fitting (See Photo 6, below).

Install 1/2" plastic plug into back of evaporator module

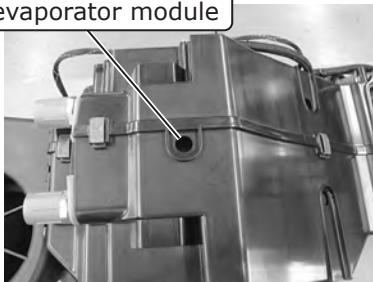

Photo 1

1/2" plastic plug



Photo 2

Install (2) 1/2" plastic plugs

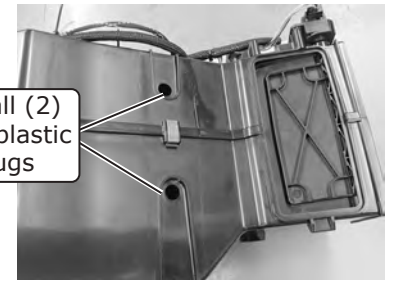

Photo 3

(2) 1/2" plastic plugs

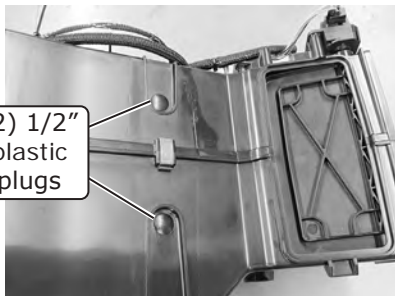
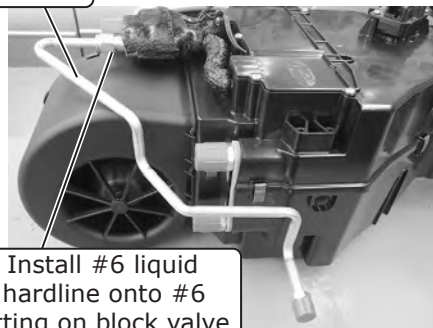

Photo 4

#6 Liquid Hardline 081967



Install #6 liquid hardline onto #6 fitting on block valve

Photo 5

Lower Heater Hardline 081965

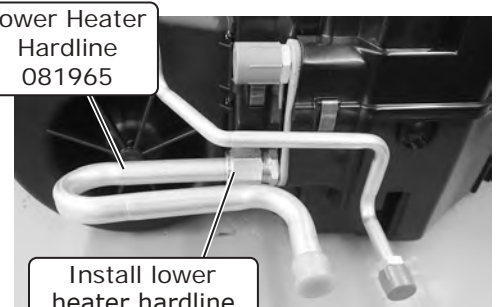

Install lower heater hardline onto lower heater fitting

Photo 6



www.vintageair.com

Evaporator Preparation (Cont.)

4. With a properly lubricated #10 O-ring (See Lubricating O-rings, Page 9), loosely install the top heater hardline onto the top heater fitting (See Photo 7, below).
5. With a properly lubricated #10 O-ring (See Lubricating O-rings, Page 9), loosely install the #10 suction hardline onto the #10 fitting on the block valve adapter (See Photo 8, below).
6. Place the evaporator firewall bracket over the evaporator hardlines, and adjust the hardlines so each hardline is centered in the bracket (See Photo 9, below). Remove the firewall bracket, then tighten the hardlines.
7. Wrap all exposed metal at the block fitting adapter of the #10 suction hardline with press tape (See Photos 10 and 11, below).
8. Route the heater control valve connector and wiring through the wiring opening on the firewall bracket (See Photo 12, below).

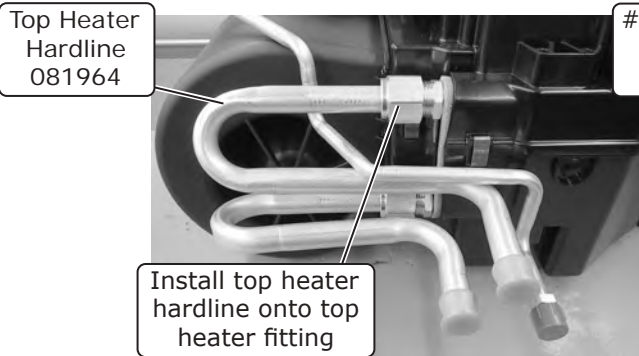

Photo 7

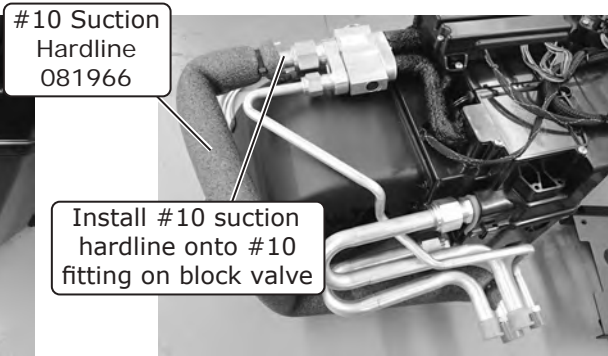

Photo 8

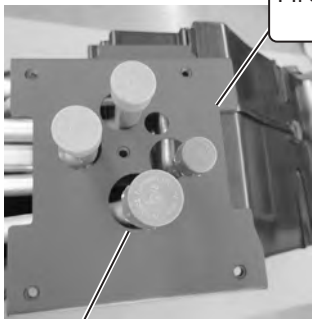

Photo 9

Install evaporator firewall bracket over evaporator hardlines

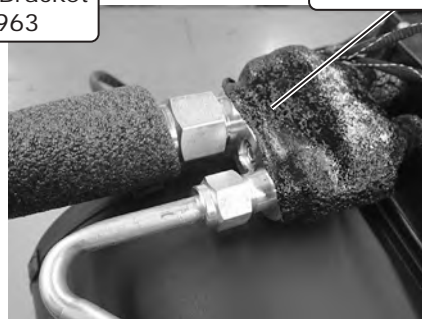

Photo 10

Wrap all exposed metal at block fitting of #10 suction hardline with press tape

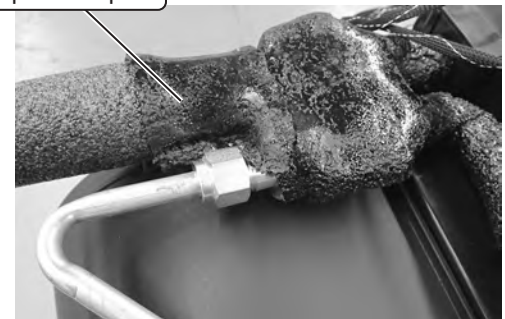

Photo 11

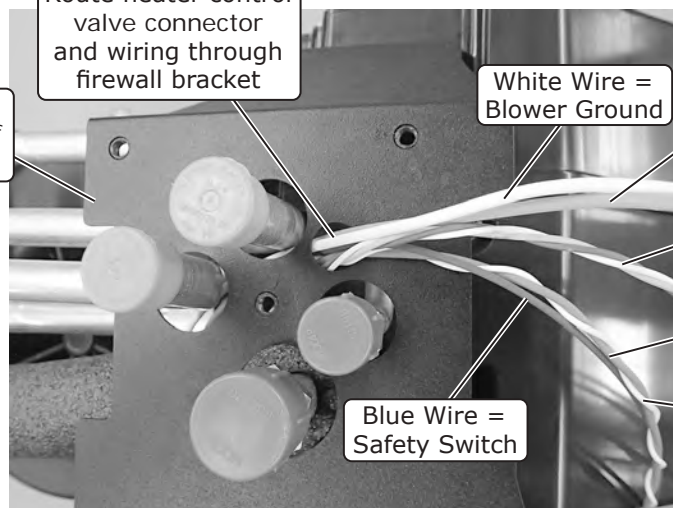

Photo 12

Install firewall bracket onto rear of evaporator case



www.vintageair.com

Evaporator Preparation (Cont.)

9. Install the firewall bracket onto the rear of the evaporator module and secure it using (4) #10 x 5/8" screws (See Photos 13, 14 and 15, below).
10. Route the heater control valve connector and wiring through the firewall bracket rubber boot, then install it over the evaporator hardlines (See Photos 16 and 17, below).
11. Install (2) 1/4-20 x 1" full-threaded studs into the top mounting holes of the evaporator mounting bracket (See Photo 18, below).
12. Using (2) spring clips, install the floor plenum onto the back of the evaporator module (See Photos 19 and 20, below).

Install firewall bracket onto rear of evaporator case



Photo 13



Secure using (4) #10 x 5/8" screws

Photo 14



Photo 15

Route heater control valve connector and wiring through firewall bracket rubber boot and install over evaporator hardlines

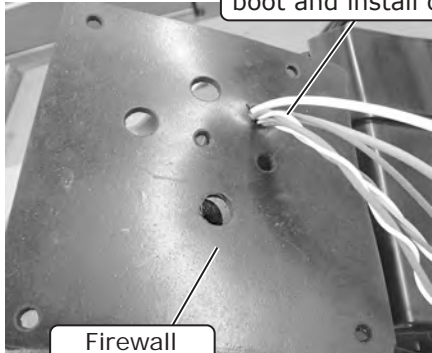

Firewall Rubber Boot 338633

Photo 16

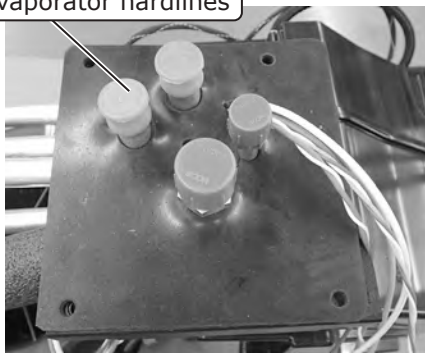

Photo 17

(2) 1/4-20 x 1" Full-Threaded Studs

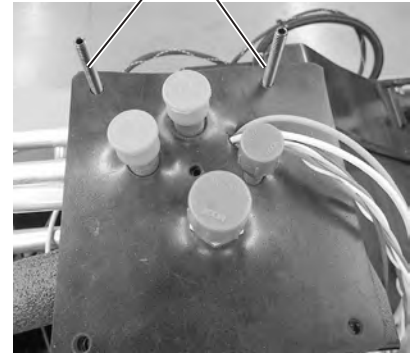
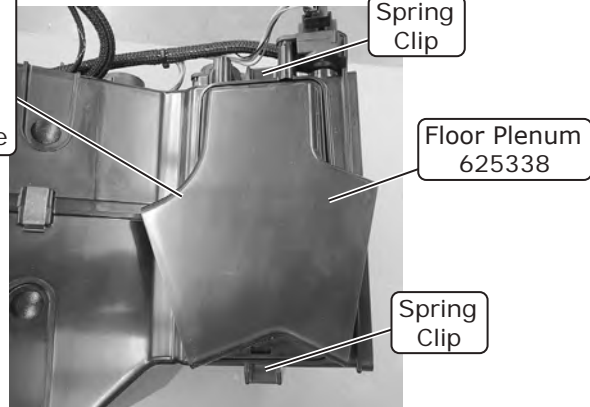

Photo 18

Using (2) spring clips, install floor plenum onto back of evaporator case



Photo 19



Spring Clip

Floor Plenum 625338

Spring Clip

Photo 20



www.vintageair.com

Evaporator Preparation (Cont.)

- Using (4) spring clips, install the dash plenum (See Photos 21, 22 and 23, below).
- Using (2) spring clips, install the defrost plenum onto the front of the evaporator module (See Photos 24 and 25, below).

Install dash plenum

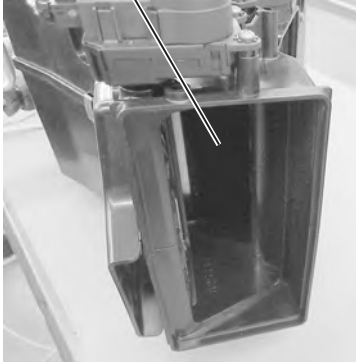

Photo 21

Dash Plenum 625330

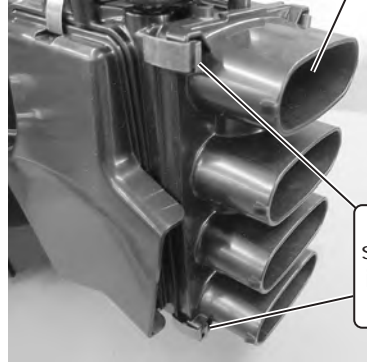

Photo 22

Using (4) spring clips, install dash plenum



Photo 23

Install defrost plenum onto front of evaporator module



Photo 24

Using (2) spring clips, install defrost plenum

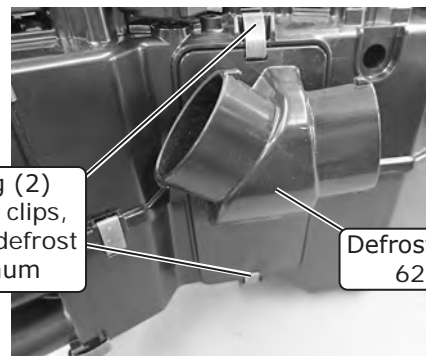

Defrost Plenum 625331

Photo 25



www.vintageair.com

Evaporator Preparation (Final)

15. Install (2) 1/4-20 well nuts into the front mounting locations (See Photo 26, below).
16. Using (2) 1/4-20 x 1" serrated flange bolts, install the evaporator dash bracket (See Photo 27, below).



Photo 26

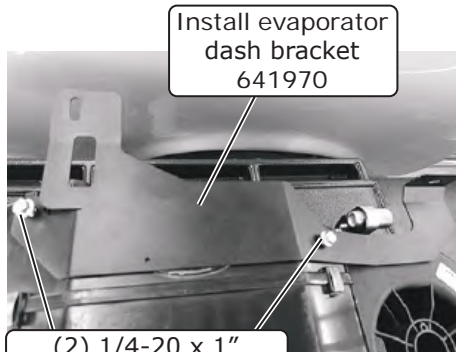

Photo 27

Evaporator Installation (Passenger Compartment)

1. Place the evaporator module on the passenger-side floorboard (See Photo 1, below).
2. Route the heater control valve connector and wiring into the engine compartment through the firewall opening. **NOTE: Leave approximately 2' of wiring between the main relay and firewall (See Photo 2, below).**
3. Replace the OEM U-nut with the supplied 1/4-20 U-nut (See Photo 3, below).
4. Lift the evaporator module into position, using the (2) 1/4-20 x 1" full-threaded studs to locate the correct mounting positions (See Photo 4, below)
5. Secure the evaporator module to the OEM bracket with a 1/4-20 x 3/4" black serrated flange bolt (See Photo 5, below).



Photo 1

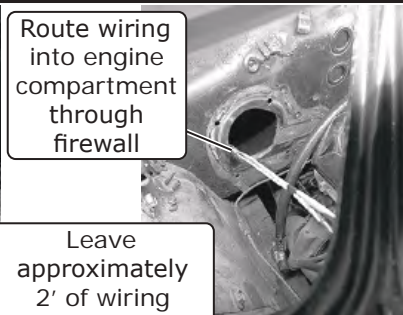

Photo 2

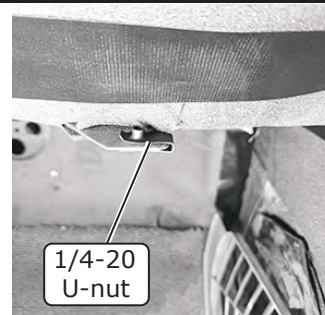

Photo 3

Place evaporator module on passenger-side floorboard

Relay

(2) 1/4-20 x 1" Full-Threaded Studs

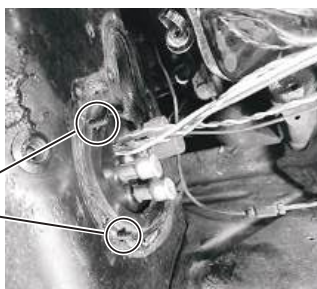

Photo 4

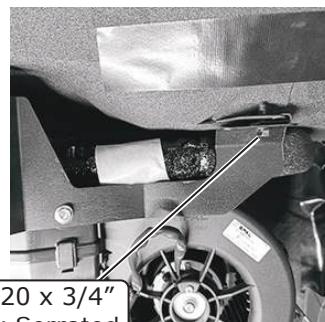

Photo 5

1/4-20 x 3/4" Black Serrated Flange Bolt



www.vintageair.com

Firewall Cover Preparation & Installation

1. Install a 1/4-20 x 3/4" black serrated flange bolt and 1/4" pushnut bolt retainer into the firewall cover as shown in Photos 1 and 2, below.
2. Apply silicone/seam sealer to the mating surface of the firewall cover (See Photo 3, below).
3. Route all wiring through the wiring hole in the firewall cover and install it over the hardlines and full-threaded studs (See Photo 4, below).

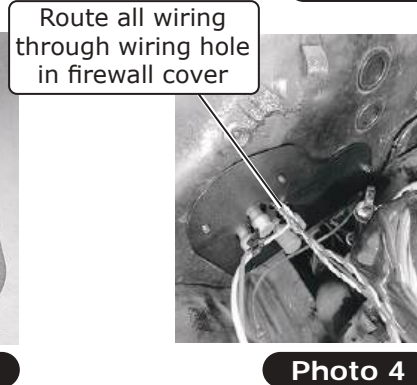
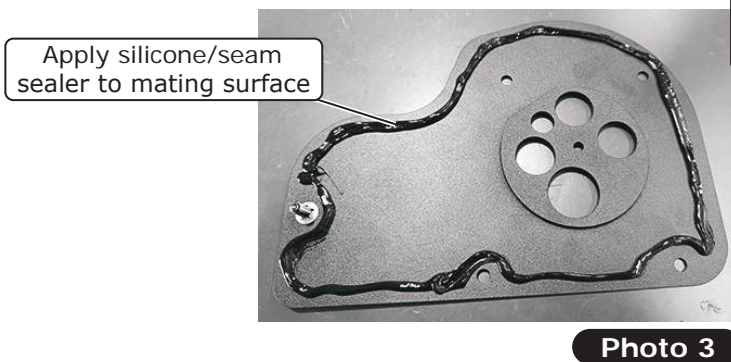
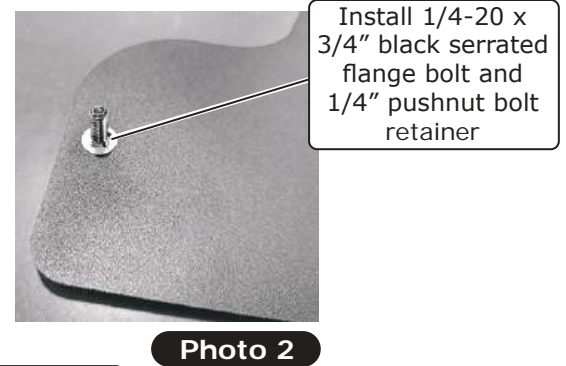
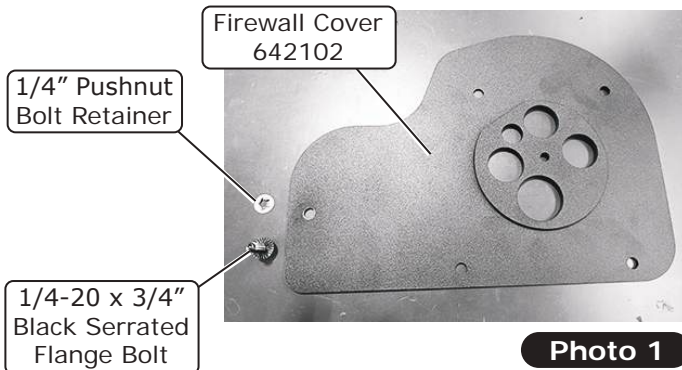

Passenger Compartment Wiring

1. Select a suitable location for the main relay, and secure it using a 10-32 x 1/2" pan head screw and a 10-32 nut with star washer. Select a suitable ground location for the white ground wire eyelet from the heater control valve harness, and secure it using a #12 x 1/2" self-tapping screw (See Photo 1, below).
 2. Route the violet power wire to a switched 12v power source on the fuse panel (See Photo 2, below).
- NOTE: This requires a male fuse extension (not supplied).**

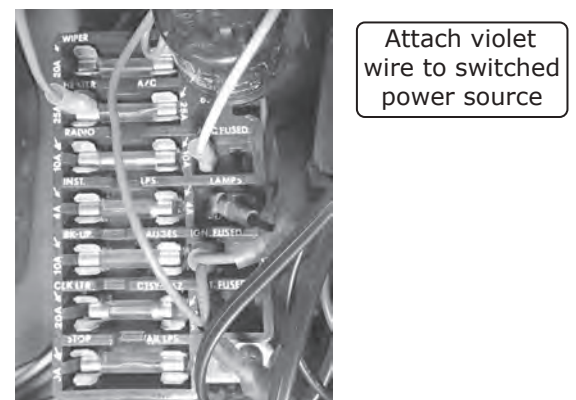
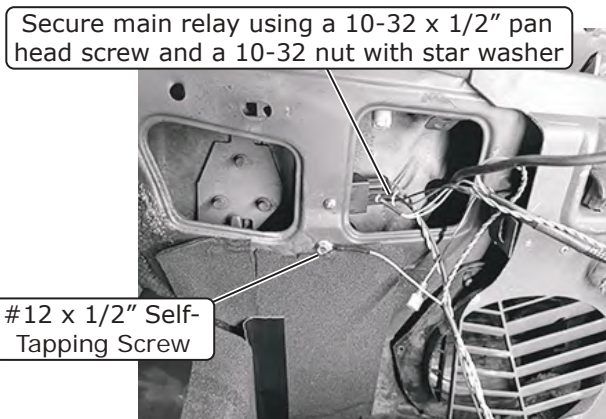



www.vintageair.com

Passenger Compartment Wiring (Cont.)

3. Connect the tan wire to the factory dash lights to enable control panel backlighting (if applicable).
4. Connect the BSC wiring to the main harness (See Photo 3, below).
5. Connect the main harness to the ECU (See Photo 4, below).

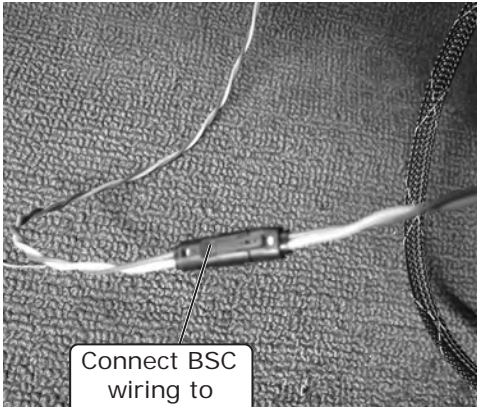

Connect BSC wiring to main harness

Photo 3

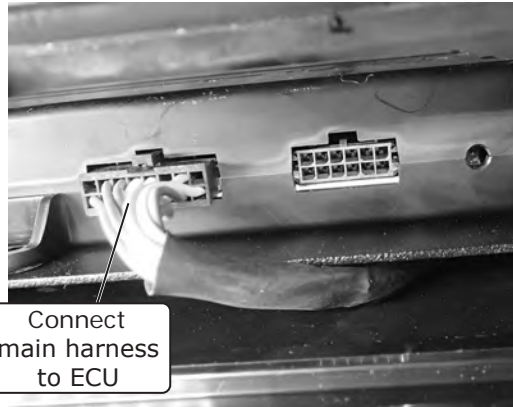

Connect main harness to ECU

Photo 4

Driver- and Passenger-Side Louver Installation

1. Cut out the template provided on Page 32. Place the driver-side template on the dash by aligning the left side of the template against the edge of the dash, then align the bottom of the template to the bottom of the dash as shown in Figure 1, below.
2. Cut out the template provided on Page 33. Place the passenger-side template on the dash by aligning the right side of the template against the edge of the dash, then align the bottom of the template to the bottom of the dash as shown in Figure 1, below.
3. Once the template is aligned correctly, use a center punch to mark the hole on the dash. Remove the template. Use a 2 3/4" hole saw to cut a hole in the dash (See Figure 1, below).
4. Install the louvers in the dash as shown in Figure 1a, below.

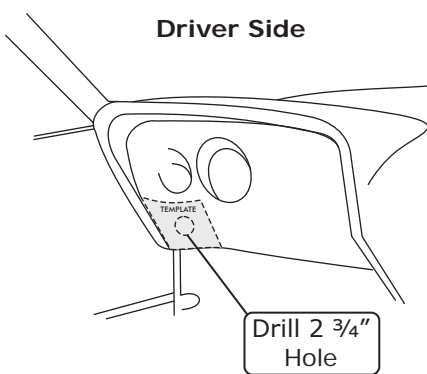

Driver Side

Drill 2 3/4" Hole

Figure 1

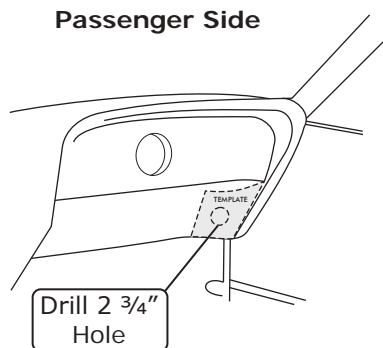

Passenger Side

Drill 2 3/4" Hole

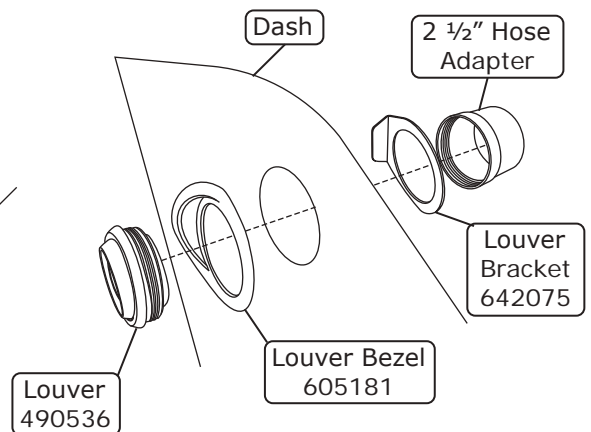

Dash

2 1/2" Hose Adapter

Louver Bracket 642075

Louver Bezel 605181

Louver 490536

Figure 1a



www.vintageair.com

Center Louver Installation (Option 1)

1. Cut out the center louver template provided on Page 34. Align the center louver template onto the dash pad as shown in Figure 1a, below.
2. Mark the center louver opening onto the dash pad. Once the center louver opening is marked, remove the template and carefully cut out the opening in the dash pad.
3. Install the center louver assembly as shown in Figure 1, below.

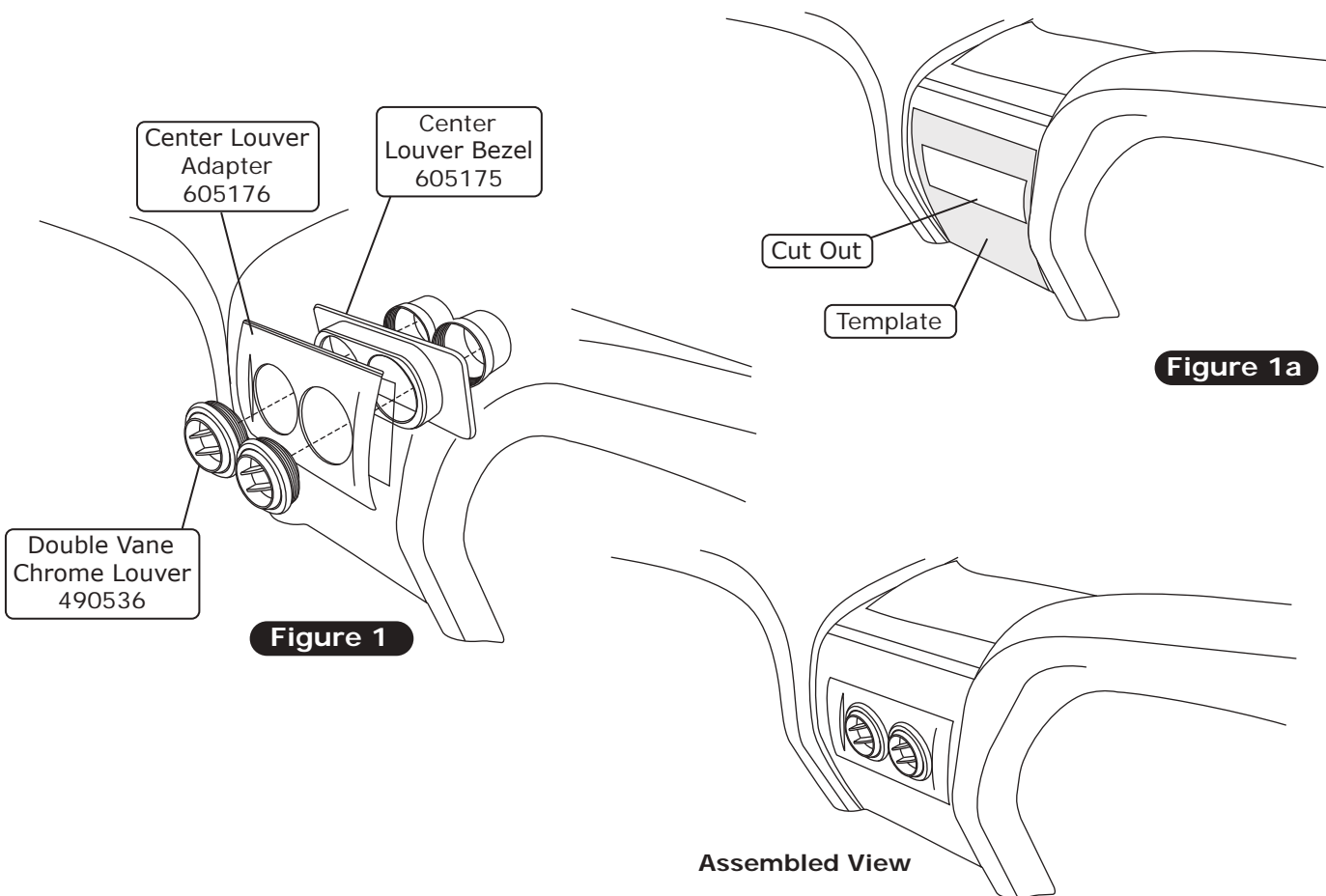

Center Louver Installation (Option 2)

1. Install the under dash louvers using (3) #8 x 1/2" pan head screws.

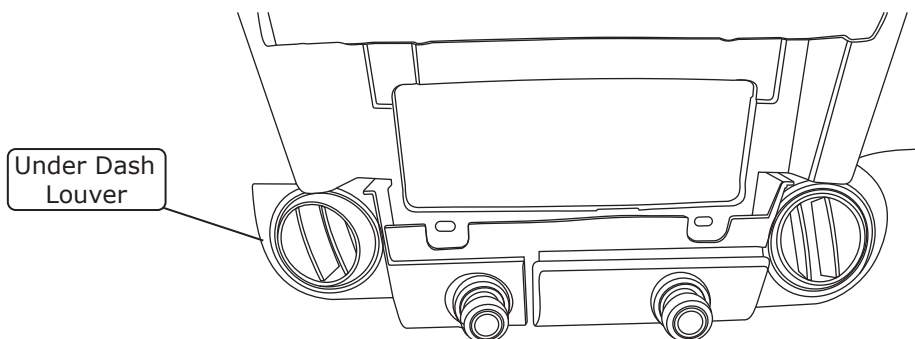



www.vintageair.com

Drain Hose Installation

1. Cut the drain hose into 3 segments at the designated lengths of 2", 2 1/2" and 4 1/2" (See Photo 1, below).
2. With the (2) drain elbows, connect the (3) hose segments together as shown in Photo 1, below.
3. Install the 1 1/4" O.D. x 11/16" I.D. grommet into the OEM drain hole in the floor board (See Photo 2, below).
4. Connect the 2" hose end segment to the evaporator drain. Route the other end of the drain hose assembly into the grommet and press fit the elbow into the grommet for a tight seal (See Photo 3, below).
5. Route the drain hose away from exhaust (See Photo 4, below).

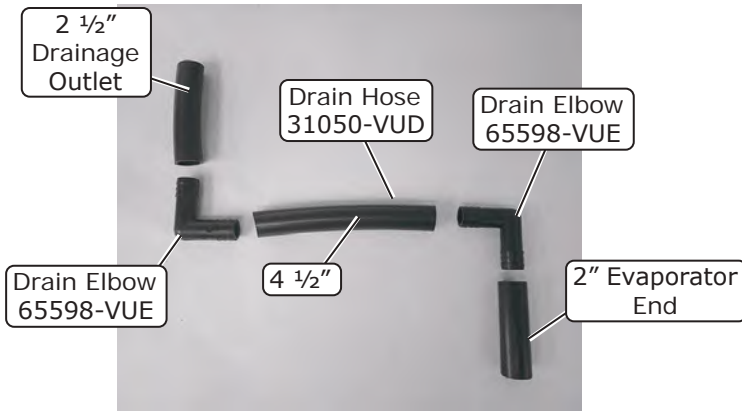

Photo 1

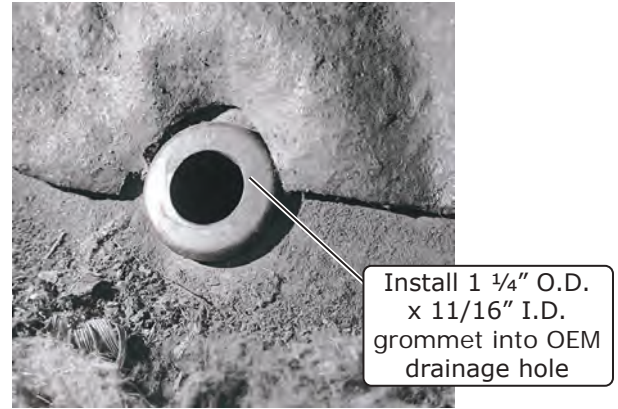

Photo 2

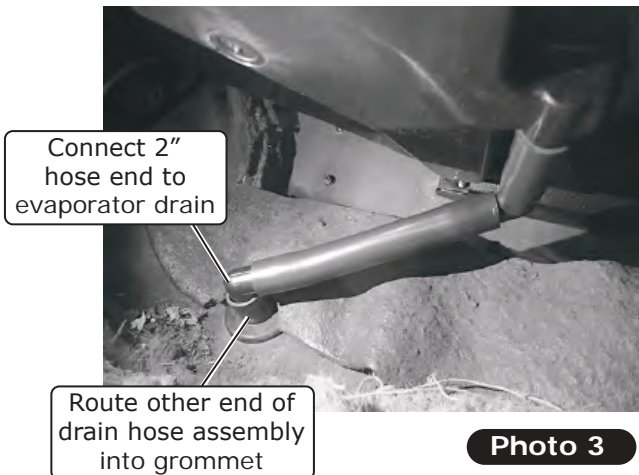

Photo 3



Photo 4



www.vintageair.com

A/C Hose Installation

Standard Hose Kit:

1. Locate the #6 evaporator/drier A/C hose (See Photo 1, below). Lubricate (2) #6 O-rings (See Lubricating O-rings, Page 9), and connect the straight female fitting to the #6 drier hardline coming through the radiator core support (See Photo 2, below). Route the 90° female fitting to the #6 evaporator hardline coming through the firewall (See Photo 1, below). Tighten each fitting connection as shown in Lubricating O-rings, Page 9.
2. Locate the #10 compressor A/C hose (See Photo 3, below). Lubricate (2) #10 O-rings (See Lubricating O-rings, Page 9), and connect the 90° female fitting to the #10 suction port on the compressor (See Photo 4, below). Route the 90° female fitting with service port to the #10 evaporator hardline coming through the firewall (See Photo 3, below). Tighten each fitting connection as shown in Lubricating O-rings, Page 9.
3. Locate the #8 compressor A/C hose. Lubricate (2) #8 O-rings (See Lubricating O-rings, Page 8), and connect the 135° fitting to the #8 discharge port on the compressor (See Photo 4, below). Route the straight female fitting with service port to the #8 condenser hardline coming through the radiator core support (See Photo 2, below). Tighten each fitting connection as shown in Lubricating O-rings, Page 9.
4. Use (6) tie wraps to secure the #6 A/C hose to the brace as shown in Figure 1, Page 21.

Modified Hose Kit:

1. Refer to separate instructions included with modified hose kit.

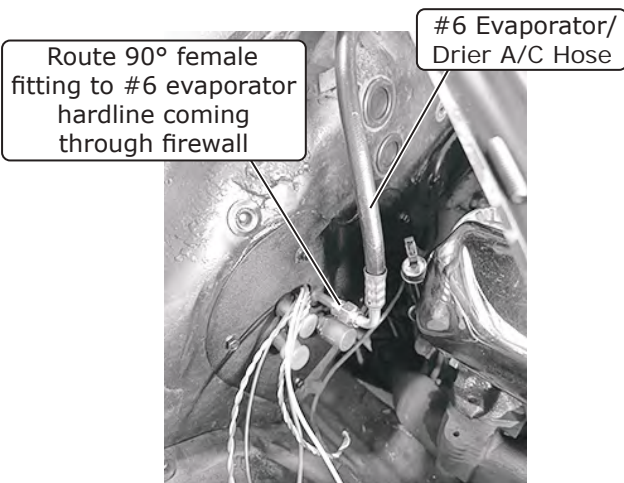

Photo 1

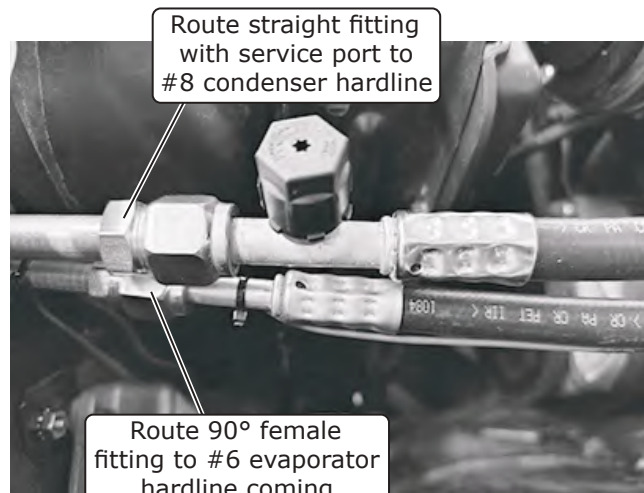

Photo 2

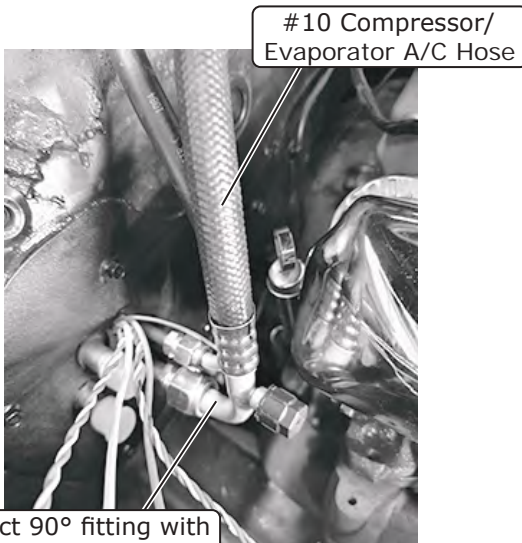

Photo 3

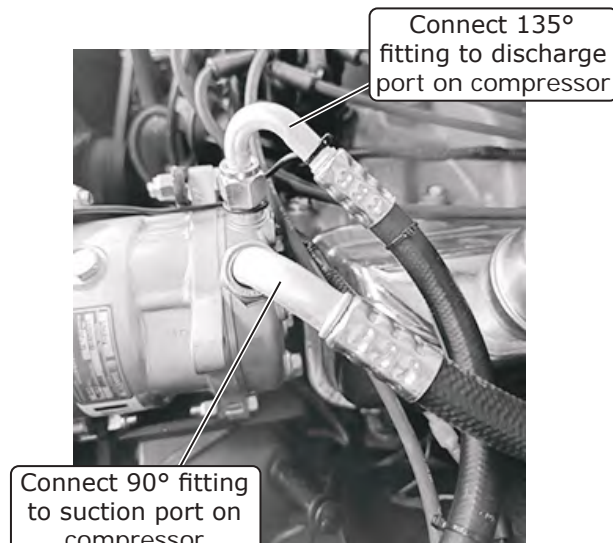

Photo 4



www.vintageair.com

Heater Hose & Heater Control Valve Installation

NOTE: Vintage Air systems use 5/8" heater connections. On engines equipped with 3/4" hose nipples, these will need to be removed and replaced with 5/8" nipples (not supplied). For water pumps with a cast-in 3/4" heater outlet, a 3/4" x 5/8" reducer fitting (not supplied) or molded hose will need to be installed in the heater hose.

1. Route a length of heater hose from the lower heater hardline to the water pump fitting, then secure it using (2) hose clamps.
2. Cut a length of heater hose approximately 4" to 5" from the firewall cover, then install it onto the upper heater hardline. Install the heater control valve and secure it with (2) hose clamps. **NOTE: Ensure proper flow direction through the heater control valve. The flow direction follows the molded arrow on the valve (See Figure 1, below).**
3. Install another length of heater hose from the heater control valve to the intake, then secure it with (2) hose clamps.
4. Plug the heater control valve connector into the heater control valve connector wiring harness.

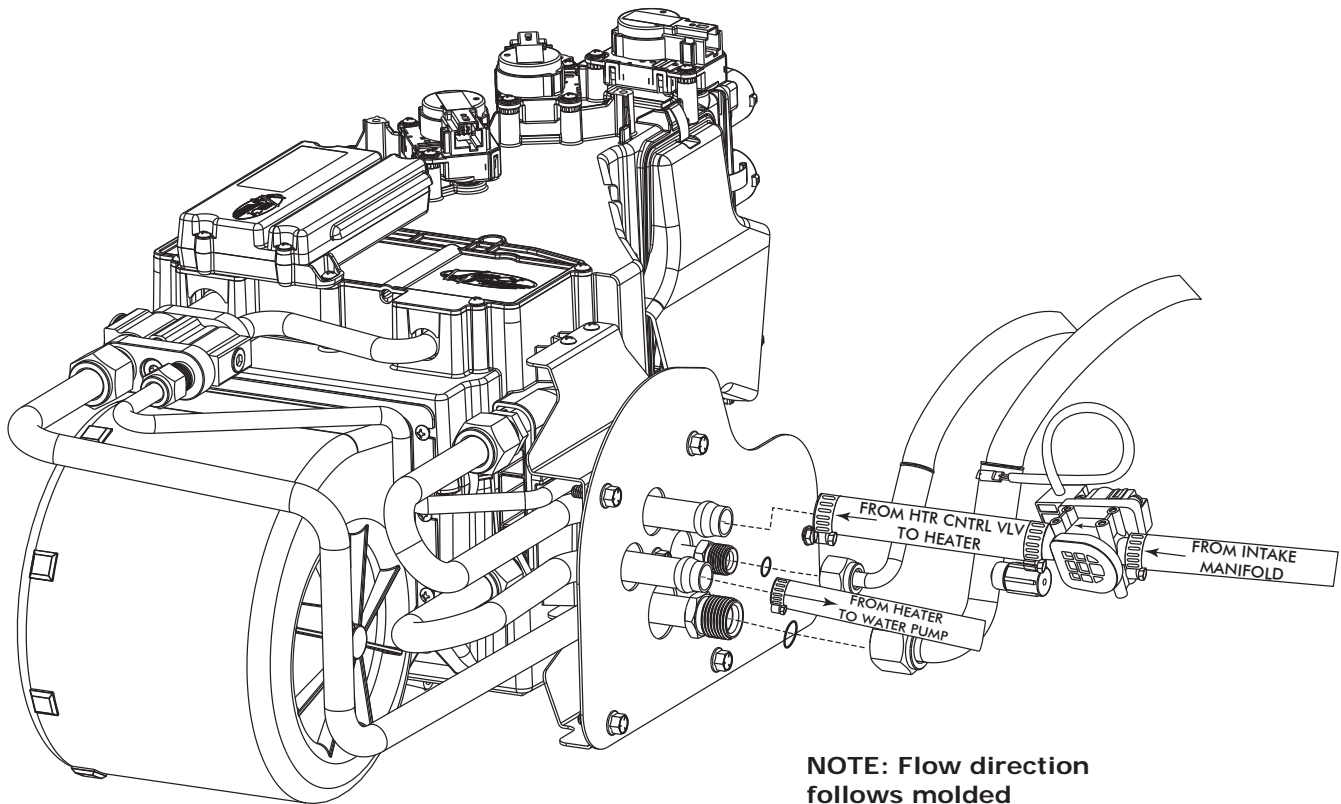

Figure 1

NOTE: Flow direction follows molded arrow on valve.



www.vintageair.com

Driver Side A/C and Heater Hose Routing

NOTE: Vintage Air Systems use 5/8" heater connections. On engines equipped with 3/4" hose nipples, these will need to be removed and replaced with 5/8" nipples (not supplied). For water pumps with a cast-in 3/4" heater outlet, a 3/4" x 5/8" reducer fitting (not supplied) or molded hose will need to be installed in the heater hose.

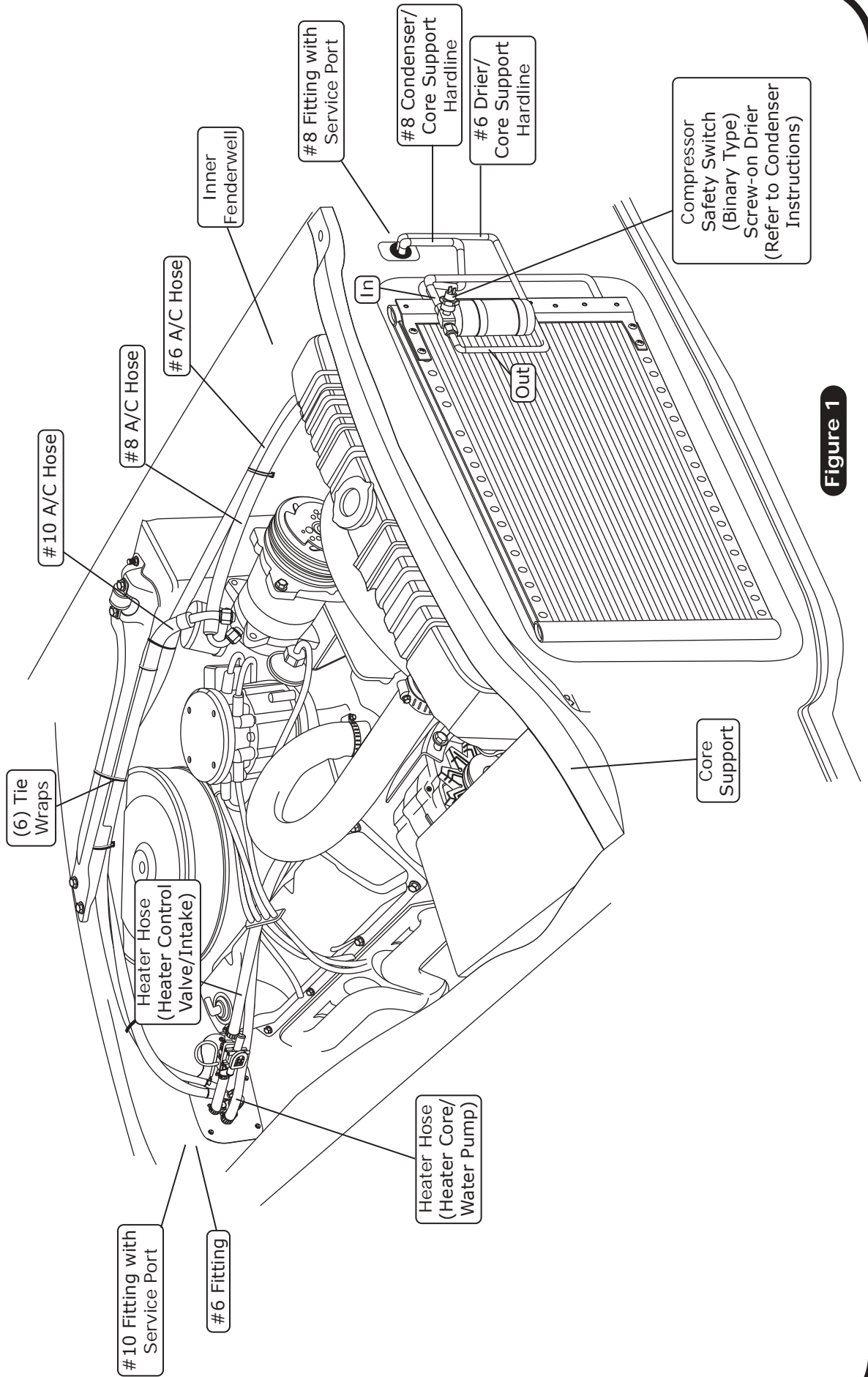

Compressor Safety Switch (Binary Type) Screw-on Drier (Refer to Condenser Instructions)

Figure 1



www.vintageair.com

Engine Compartment Wiring

1. Route power and ground wires toward the battery.
 2. Install the supplied heat shrink over the 12 AWG orange fuse holder assembly wire, and crimp it to the 12 AWG orange wire from the main wiring harness (See Photo 1, below and Quality Crimp Guidelines, Page 28).
 3. Install the supplied heat shrink over the 16 AWG black fuse holder assembly wire, and crimp it to the 16 AWG red wire from the main wiring harness (See Photo 2, below and Quality Crimp Guidelines, Page 28).
 4. Install fuses into the holders (See Photo 3, below).
 5. Install the supplied heat shrink over the white ground wires, then crimp on the supplied eyelets (See Photos 4 and 5, below and Quality Crimp Guidelines, Page 28)
 6. Connect the ground wiring eyelets to the negative battery terminal connector (See Photo 6, below).
 7. Connect the positive wiring eyelets to the positive battery terminal connector (See Photo 7, below).
- NOTE: Do not connect power until installation is completed.**

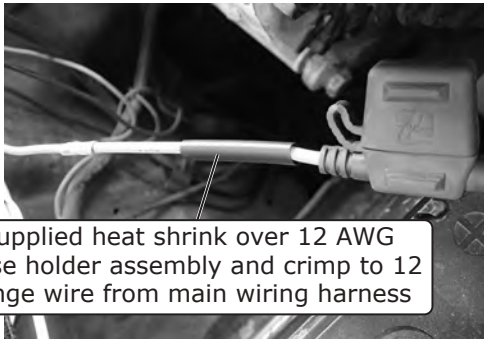

Install supplied heat shrink over 12 AWG orange fuse holder assembly and crimp to 12 AWG orange wire from main wiring harness

Photo 1

Install supplied heat shrink over 16 AWG black fuse holder assembly wire and crimp to 16 AWG red wire from main wiring harness



Photo 2

Install fuses into holders



Photo 3

Install supplied heat shrink over white ground wires and crimp on supplied eyelets

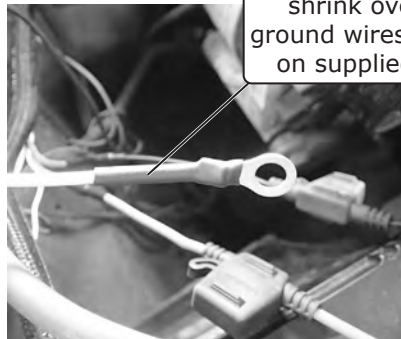

Photo 4

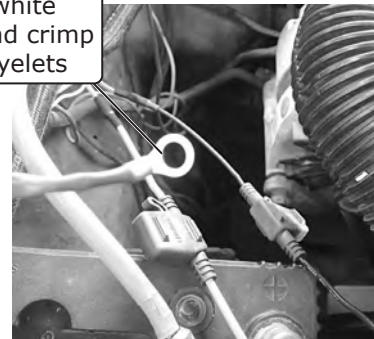

Photo 5

Connect ground wiring eyelets to negative battery terminal connector

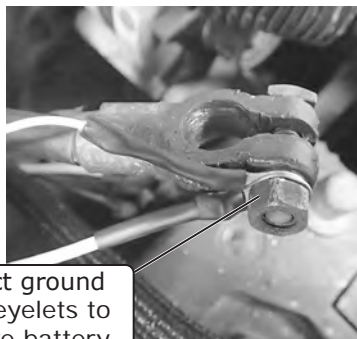

Photo 6

NOTE: Do not connect power until installation is completed.

Connect positive wiring eyelets to positive battery terminal connector



Photo 7



www.vintageair.com

Final Steps: Installation Check

Installation Check	
ITEM TO CHECK	Procedure
<input type="checkbox"/>	<p>ECU</p> <p>If no blinking is observed after 1 minute of turning the ignition on, go to the next check.</p> <p>If repetitive blinking is observed, go to the Advanced Diagnostics Section to diagnose.</p>
<input type="checkbox"/>	<p>Blower speed control</p> <p>Set the blower speed control to OFF, <u>confirm that the blower is off</u>.</p> <p>Position the blower speed control to LOW then MEDIUM and then HIGH. <u>At each setting confirm that the blower speed increases</u>, do this by feeling for the amount of air coming from the unit and hearing the blower speed increase.</p>
<input type="checkbox"/>	<p>Mode control</p> <p>Set the MODE control to the DASH position. <u>Confirm that air is being blown at the dash vents</u>.</p> <p>Set the MODE control to the FLOOR position. <u>Confirm that air is being blown at the floor vents</u>.</p> <p>Set the MODE control to the DEFROST position. <u>Confirm that all air is being blown from the defrost vents</u></p> <p>If heater lines are installed:</p> <p>Set the MODE control to the DASH position. Set the TEMP control to the MAX HEAT position. <u>Confirm that HOT air is coming from the dash vents</u>.</p>
<input type="checkbox"/>	<p>Temperature control</p> <p>If system is charged:</p> <p>Set the TEMP control to the MAX COOL position. <u>Confirm that COLD air is coming from the dash vents</u>.</p> <p>Also <u>confirm that the compressor "clicks" on</u> when adjusting the TEMP control from the MAX HEAT position to the MAX COOL position.</p>
<input type="checkbox"/>	<p>AC Indicator (If applicable)</p> <p>While the MODE control is set to the DASH position, and the TEMP control is set to the MAX COOL/MIN HEAT position, <u>confirm that the blue AC Indicator light is on</u>.</p>
<input type="checkbox"/>	<p>Backlight (If applicable)</p> <p>If your control panel has backlight capabilities and has been wired, turn the dash lamp on and <u>confirm that the AC panel's legend is lit</u>.</p>
<input type="checkbox"/>	<p>Fittings</p> <p>Verify AC and Heater fittings are all tight.</p>



www.vintageair.com

Final Steps: Completing the Install

1. Install the duct hoses as shown in Figure 1, Page 25.
2. Install the control panel assembly. **NOTE: Controls must be calibrated for proper operation. Refer to control panel instructions.**
3. Install the glove box.
4. Reinstall all previously removed items.
5. Fill radiator with at least a 50/50 mixture of approved antifreeze and distilled water. It is the owner's responsibility to keep the freeze protection at the proper level for the climate in which the vehicle is operated. Failure to follow antifreeze recommendations will cause heater core to corrode prematurely and possibly burst in A/C mode and/or freezing weather, voiding your warranty.
6. Double check all fittings, brackets and belts for tightness.
7. Vintage Air recommends that all A/C systems be serviced by a licensed automotive A/C technician.
8. Evacuate the system for a minimum of 45 minutes prior to charging, and perform a leak check prior to servicing.
9. Charge the system to the capacities stated on Page 4 of this instruction manual.
10. See Operation of Controls procedures on Page 29.



www.vintageair.com

Duct Hose Routing

NOTE: For the system to function optimally, the duct hoses must be routed as directly as possible, taking care to avoid kinks, sharp bends and unnecessary length. Vintage Air supplies duct hoses in continuous lengths that will need to be cut to size depending on application. Before cutting, familiarize yourself with the installation instructions and verify the routing will work with your application. For custom hose routing, additional hose may be needed and can be purchased from Vintage Air.

1. Stretch the duct hose until there is no slack, measure, mark and cut hose to size (See Photo 1, below).

Stretch, measure, mark and cut hose to size



Photo 1

Disclaimer: Before cutting duct hose to length, verify the routing will work for your application.

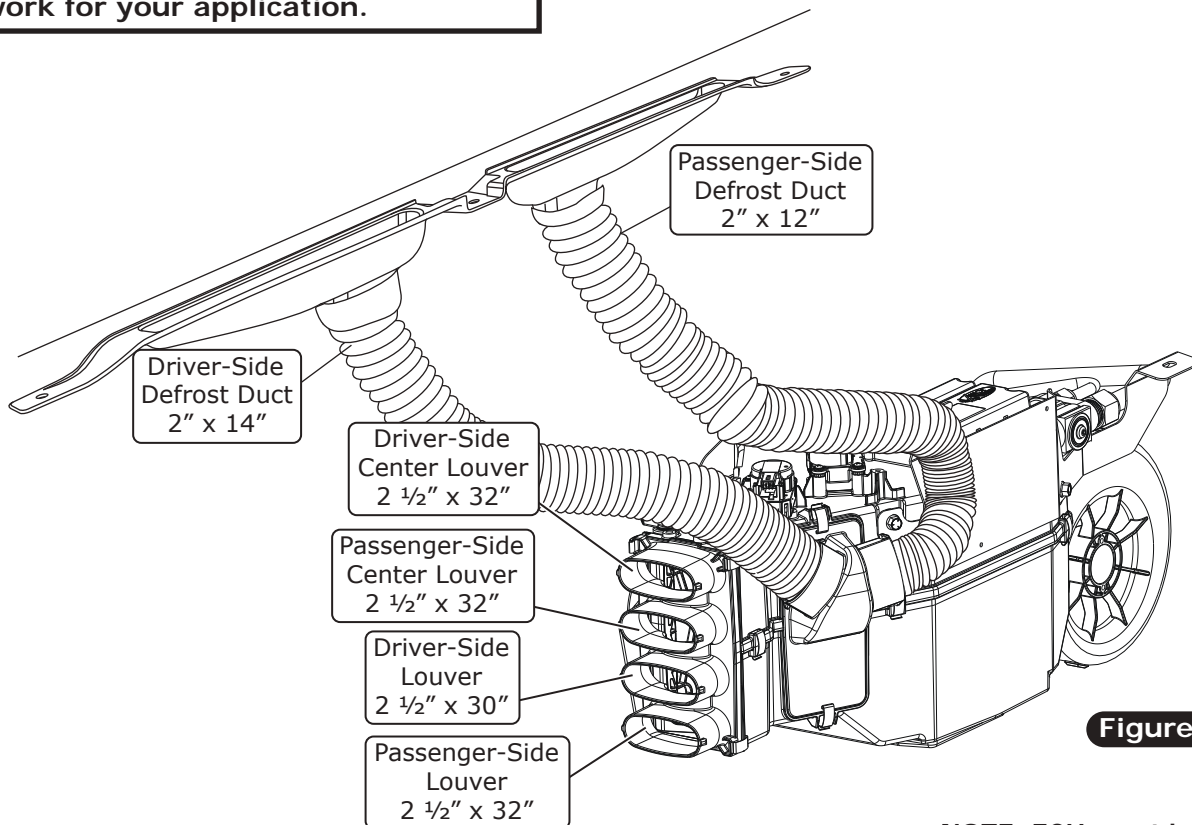

Figure 1



NOTE: ECU must be placed away from water and humidity, and also be accessible for servicing. If relocating, connectors must be positioned towards the bottom.

Position connectors towards bottom



www.vintageair.com

Quality Crimp Guideline

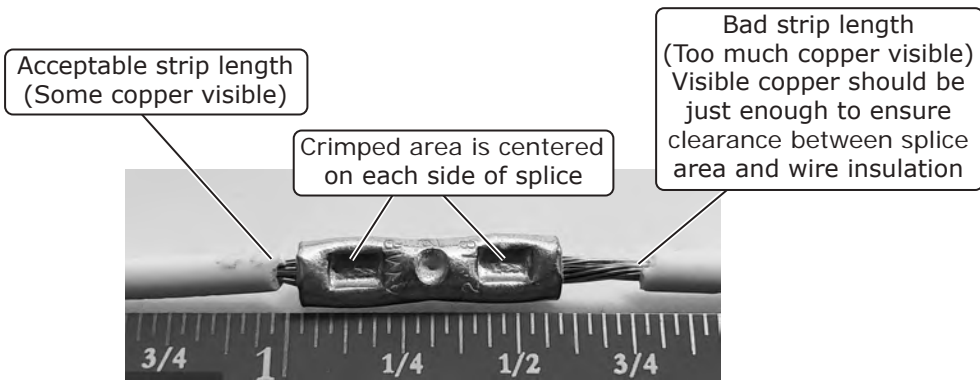

Photo 1

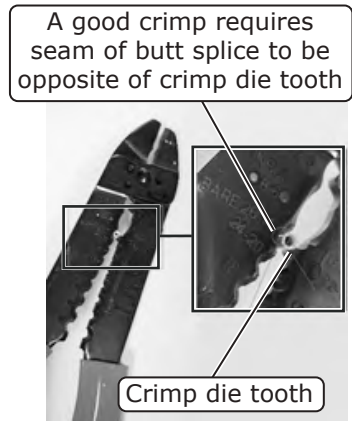

Photo 2

Good Ring Terminal Crimp Bad Ring Terminal Crimp



Photo 3

Crimp area is centered on barrel

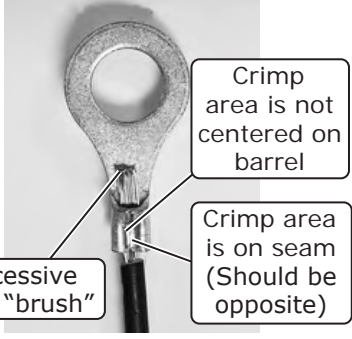

Photo 4

Excessive wire "brush"

Crimp area is not centered on barrel

Crimp area is on seam (Should be opposite)

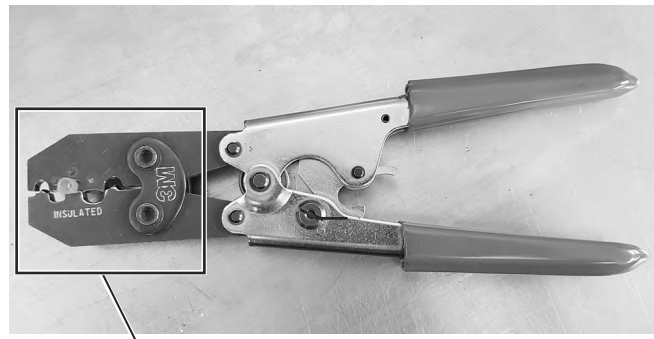

Photo 5

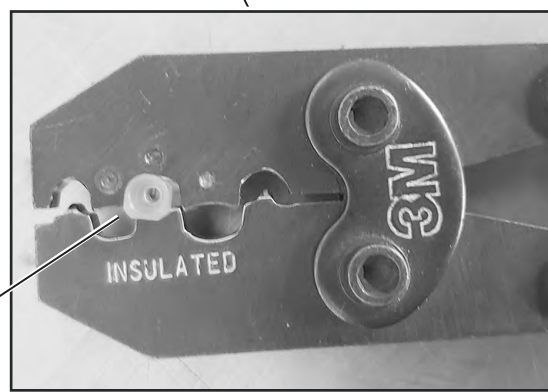

Photo 5a

Use a ratcheting crimp tool for insulated barrel terminals when crimping the provided female insulated terminal. Ensure terminal is inserted in appropriate position before crimping.



www.vintageair.com

Gen 5 Wiring Diagram

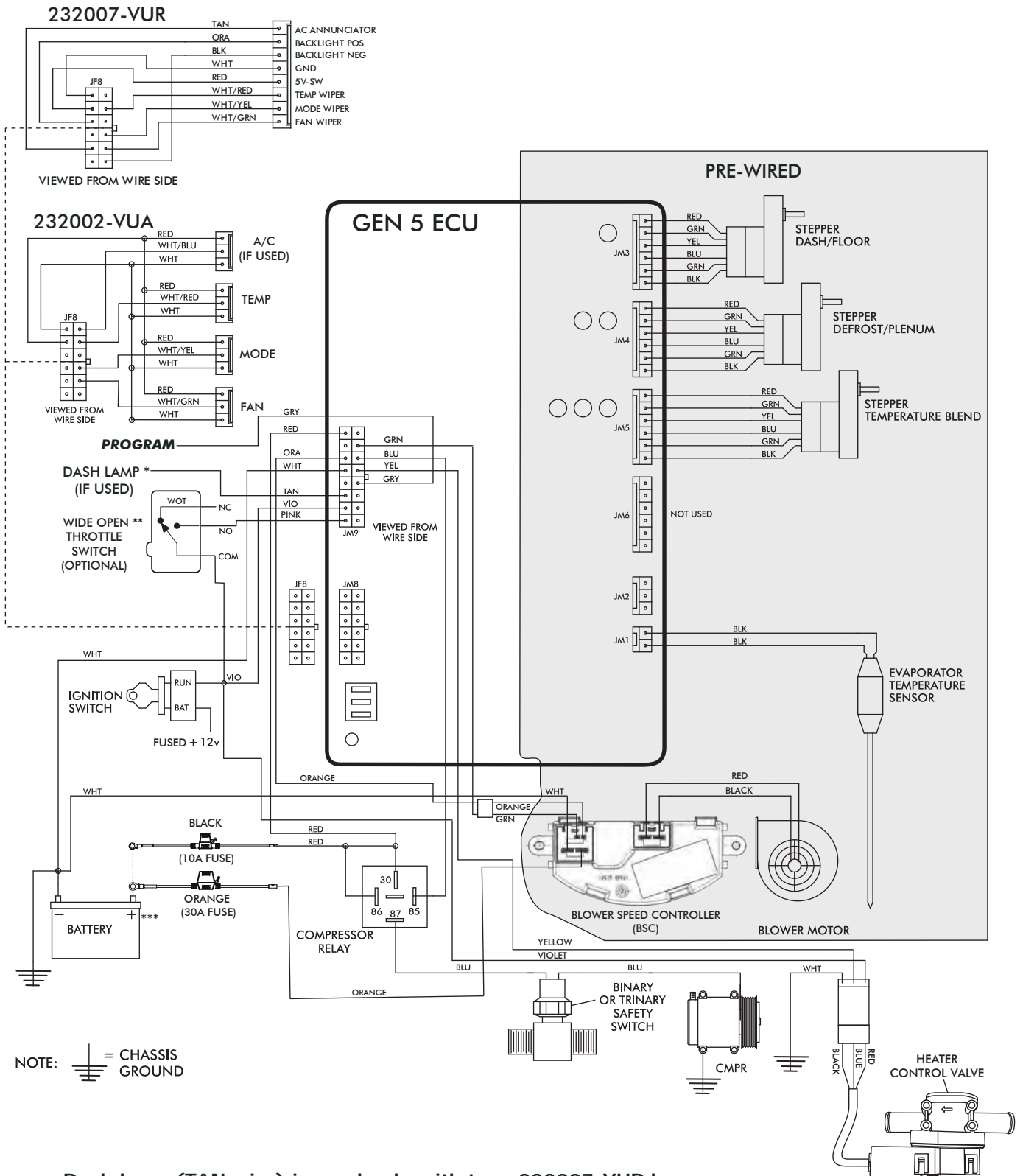

NOTE: = CHASSIS GROUND

- * Dash lamp (TAN wire) is used only with type 232007-VUR harness.
- ** Wide open throttle switch contacts close only at full throttle, which disables A/C compressor.
- *** Install fuse assemblies at or as near to the battery as possible.



www.vintageair.com

Gen 5 Wiring Instructions

WIRING HARNESS (231505) ↓

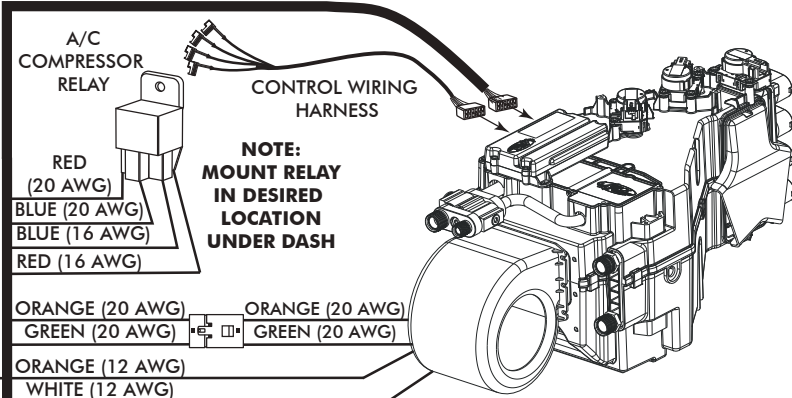

Ignition Switch:
Using provided butt splice (PN 226004), connect the 20 AWG violet wire to a 5A fused and switched 12V source such as Key On.

Wide Open Throttle Switch (Optional):
If a wide open throttle switch is required, connect the 20 AWG pink wire to a normally open switch that, when closed, connects a fused and switched 12V source to the pink wire. See Gen 5 wiring diagram for an example.

Dash Light (Optional):
If using a Vintage Air control panel with back light, connect the 20 AWG tan wire to the vehicle's dash back light 0-12V using provided butt splice (PN 226004).

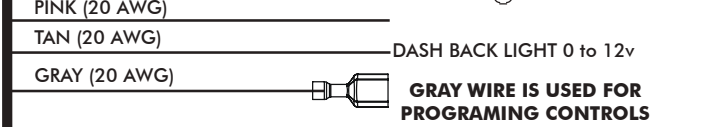

FIREWALL

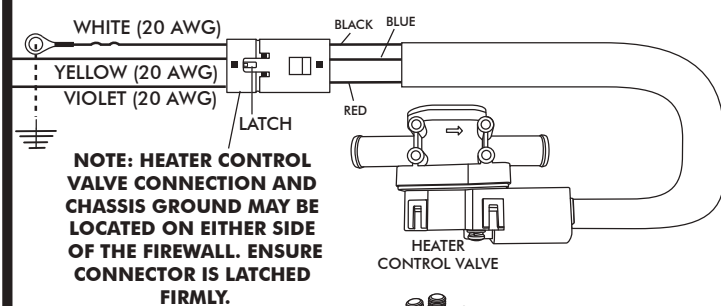

Heater Control Valve:
Connect the Violet/Yellow/White twisted branch with 3 position connector into the heater control valve connector. Ensure that the mating latch is fully seated.

Binary/Trinary & Compressor:
Binary Switch: Terminate provided insulated female terminal (PN 23172-VUW) to the blue 16 AWG wire. Connect as shown.
Trinary Switch: Connect according to trinary switch wiring diagram.

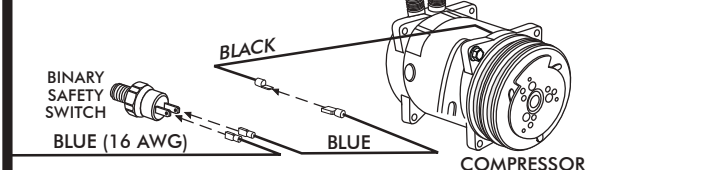

Battery Connections:
ECU Ground: Terminate provided ring terminal (PN 226110) to 20 AWG white wire from the 231505 wire assembly and install at battery.
ECU PWR: Terminate provided fuse assembly with black leads (PN 233012) to the 16 AWG red wire from the 231505 wire assembly. Install provided 10A Red Mini Fuse (PN 226118). Install at battery.
Blower Speed Controller (BSC) Ground: Terminate provided ring terminal (PN 226111) to 12 AWG white wire from the 232020 wire assembly and install at battery.
Blower Speed Controller (BSC) PWR: Terminate provided fuse assembly with orange leads (PN 233008) to the 12 AWG orange wire from the 232020 wire assembly. Install provided 30A Green ATO/ATC Fuse (PN 226125). Install at battery.

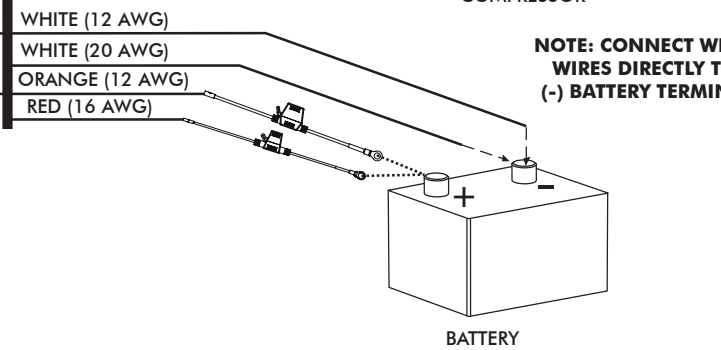



www.vintageair.com

Operation of Controls

On Gen IV or Gen 5 systems with three lever/knob controls, the temperature control toggles between heat and A/C operations. To activate A/C, move the temperature lever/knob all the way to cold and then back it off to the desired vent temperature. For heat operation, move the temperature lever/knob all the way to hot and then adjust to the desired vent temperature. The blower will momentarily change speed, each time you toggle in and out of heat and A/C operations, to indicate the change.

Blower Speed

This lever/knob controls blower speed, from OFF to HI.

Mode Control

This lever/knob controls the mode positions, from DASH to FLOOR to DEFROST, with a blend in between.

Temperature Control

This lever/knob controls the temperature, from HOT to COLD.

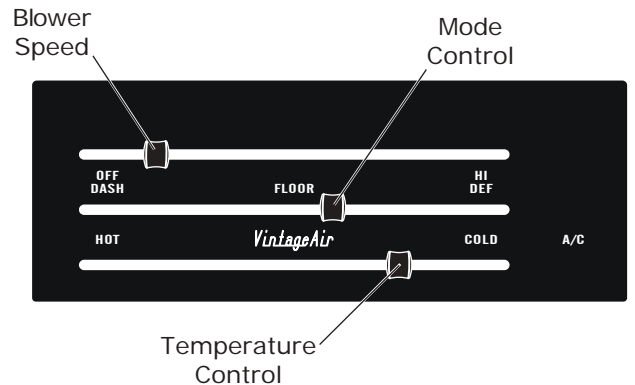

A/C Operation

Blower Speed

Adjust to desired speed.

Mode Control

Adjust to desired mode position (DASH position recommended).

Temperature Control

For A/C operation, adjust to coldest position to engage compressor (adjust between HOT and COLD to reach desired temperature).

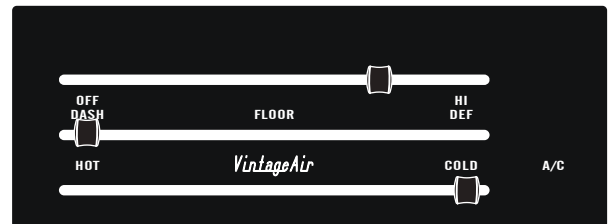

Heat Operation

Blower Speed

Adjust to desired speed.

Mode Control

Adjust to desired mode position (FLOOR position recommended).

Temperature Control

For maximum heating, adjust to hottest position (adjust between HOT and COLD to reach desired temperature).

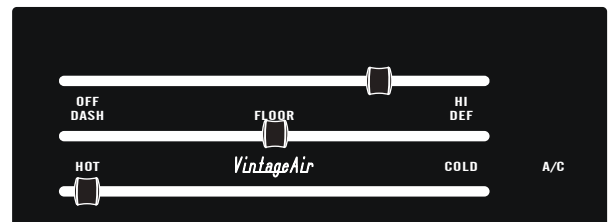

Defrost/De-fog Operation

Blower Speed

Adjust to desired speed.

Temperature Control

Adjust to desired temperature.

Mode Control

Adjust to DEFROST position for maximum defrost, or between FLOOR and DEFROST positions for a bi-level blend (Compressor is automatically engaged).





www.vintageair.com

Troubleshooting Guide

This printed troubleshooting guide is our basic guide that covers common installation problems. To see our advanced diagnostics and troubleshooting guide, please refer to the following page for instructions on how to download the complete guide.

WARNING: While troubleshooting the system, never probe connector terminals from the front mating side, only back probe.

WARNING: While troubleshooting the system, never use automotive check lights.

Symptom	Condition	Checks	Actions	Notes
1. Blower stays on high speed with ignition on.	No other functions work.	Check for damaged pins or wires in the control panel wire assembly and mating header at ECU.	If found damaged, replace wire assembly or ECU.	If fuse continues to blow, there is a serious problem in the wiring. Check all wiring and ensure the wire is not damaged and shorting out along its route.
	All other functions work.	Check for a bad ECU GND. Check for damaged pins or wires in the control panel wire assembly and mating header at ECU. Check if Blower power fuse is blown. Check for a bad ECU GND.	If found damaged, replace wire assembly or ECU. Replace fuse. Repair connection.	
2. Compressor will not turn on (All other functions work).	System is not charged.	System must be charged for compressor to engage.	Charge system.	Danger: Never bypass safety switch with engine running. Serious injury can result.
	System is charged.	Check for faulty A/C potentiometer or associated wiring (not applicable to 3-pot controls).	Check continuity to ground on white control head wire. Check for 5V on red control head wire.	To check for proper pot function, check voltage at white/red wire. Voltage should be between 0V and 5V, and will vary with pot lever position.
		Check for disconnected or faulty thermistor.	Check 2-pin connector at ECU housing.	Disconnected or faulty thermistor will cause compressor to be disabled.
3. Compressor will not turn off (All other functions work).	Compressor will not turn off (All other functions work).	Check for faulty A/C potentiometer or associated wiring.	Repair or replace pot/control wiring.	Red wire at A/C pot should have approximately 5V with ignition on. White wire will have continuity to chassis ground. White/Red wire should vary between 0V and 5V when lever is moved up or down.
		Check for faulty A/C relay.	Replace relay.	



www.vintageair.com

Troubleshooting Guide (Cont.)

Symptom	Condition	Checks	Actions	Notes
4. System will not turn on, or runs intermittently.	Works when engine is not running; shuts off when engine is started	Noise interference from either ignition or alternator.	Install capacitors on ignition coil and alternator. Ensure good ground at all points. Relocate coil and associated wiring away from ECU and ECU wiring. Check for burned or loose plug wires.	Ignition noise (radiated or conducted) will cause the system to shut down due to high voltage spikes. If this is suspected, check with a quality oscilloscope. Spikes greater than 16V will shut down the ECU. Install a radio capacitor at the positive post of the ignition coil (see radio capacitor installation bulletin). A faulty alternator or worn out battery can also result in this condition.
	Will not turn on under any conditions.	Verify connections on power lead, ignition lead, and both white ground wires. Verify battery voltage is greater than 10 volts and less than 16 while engine is running.	Check for power at ECU, and confirm ignition is being applied to ECU properly. Verify proper meter function by checking the condition of a known good battery.	
5. Loss of mode door function.	No mode change at all.	Check for damaged mode switch or potentiometer and associated wiring.		
	Blower turns on and off rapidly.	Battery voltage is at least 12V. Battery voltage is less than 12V.	Ensure all system grounds and power connections are clean and tight. Charge battery.	System shuts off blower at 10V. Poor connections or weak battery can cause shutdown at up to 11V.
7. Erratic functions of blower, mode, temp, etc.		Check for damaged switch or pot and associated wiring.	Repair or replace.	

Advanced Diagnostics and Troubleshooting Guide

If after referencing the Troubleshooting Guide, the issue is not resolved, move to The Advanced Diagnostics and Troubleshooting Guide that covers the following:

- ECU Diagnostics Codes
 1. **ECU Blink Sequence**
 2. **Firmware Version Number**
 3. **ECU Model Number**
 4. **ECU Start-Up Blink Sequence**
 5. Diagnostic Codes
- Complete Advanced Troubleshooting Guidelines

Access the latest version of the Advanced Diagnostics and Troubleshooting Guide by scanning the following QR code on your mobile device:



You can also access the guide by typing the following address into your web browser:

https://www.vintageair.com/instructions_pdf/905000.pdf



www.vintageair.com

Driver-Side Louver Template

NOTE: Due to printing variances, measure the line below before using this template. If template is scaled properly, the line should measure 6 inches.

Cut Along Dotted Line



Center Punch and Drill 2 3/4" Hole

1969-70 Mustang w/o AC
Driver Side Louver Template

Passenger-Side Louver Template

NOTE: Due to printing variances, measure the line below before using this template. If template is scaled properly, the line should measure 6 inches.

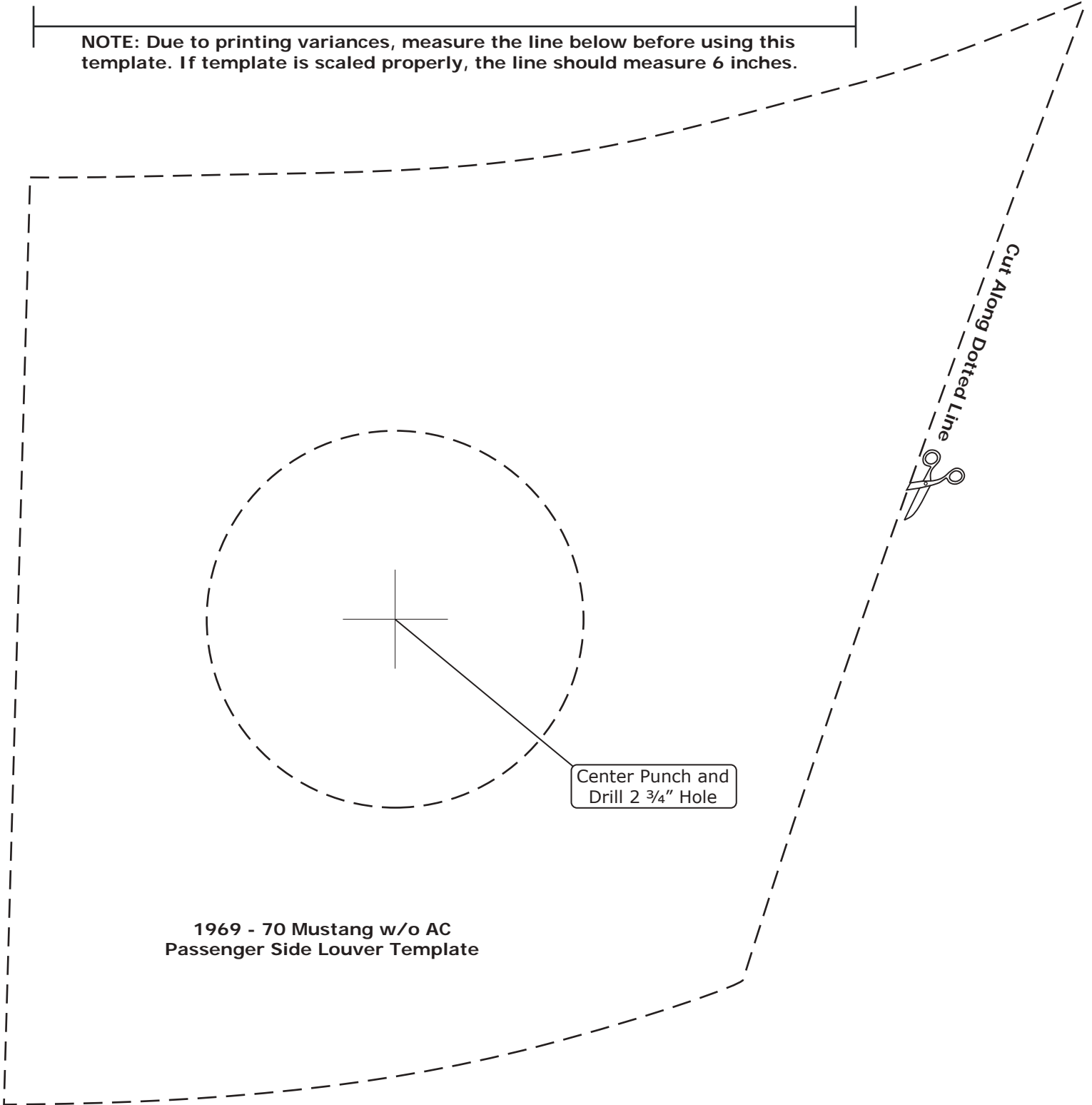

Center Punch and
Drill 2 3/4" Hole

1969 - 70 Mustang w/o AC
Passenger Side Louver Template



www.vintageair.com

Center Louver Template

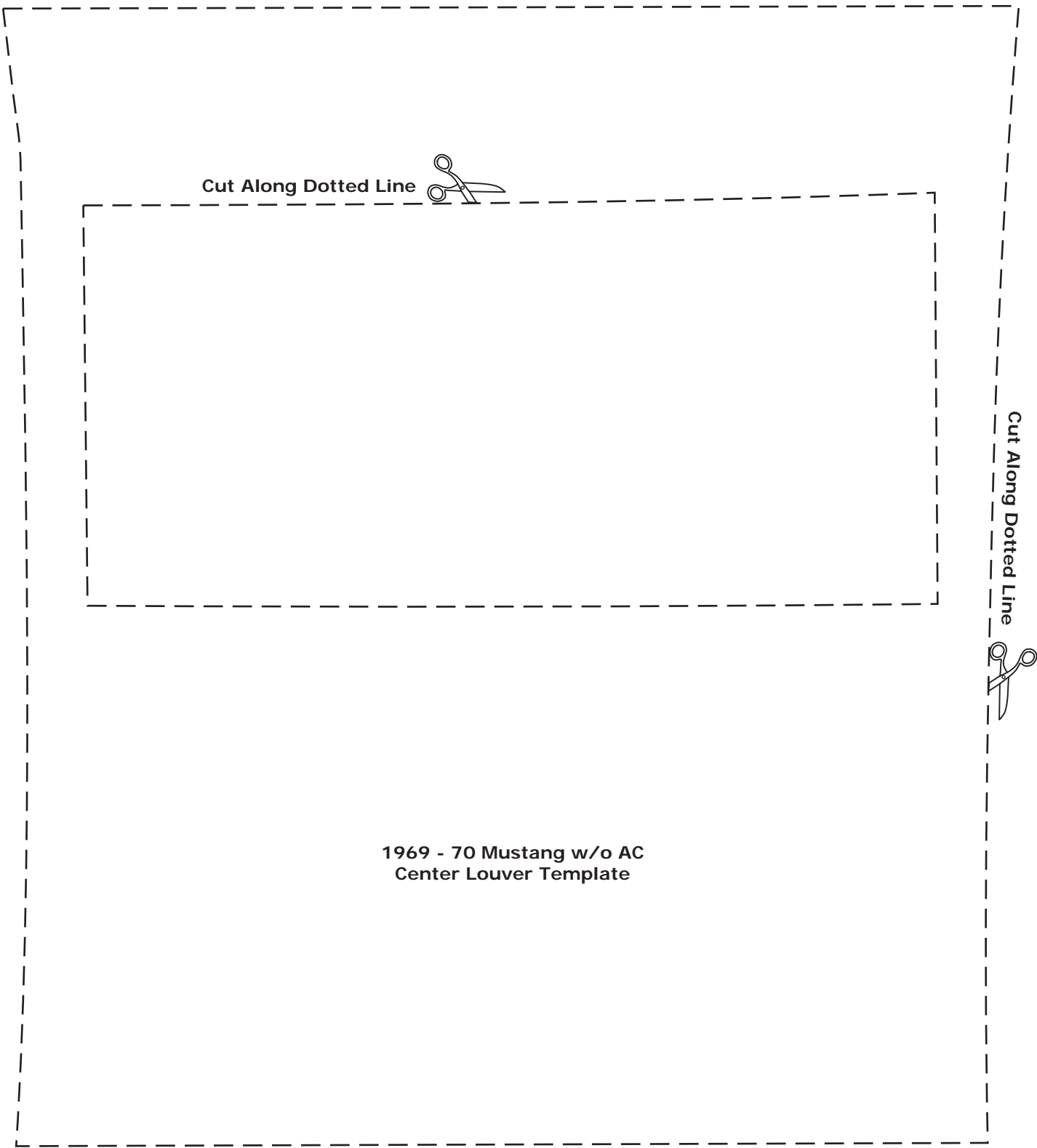

1969 - 70 Mustang w/o AC
Center Louver Template

NOTE: Due to printing variances, measure the line below before using this template. If template is scaled properly, the line should measure 6 inches.

1969 - 70 Mustang w/o AC
Firewall Cover Hole Template

Mark and drill
to 17/64"



Mark and drill
to 17/64"



Mark and drill
to 17/64"



Cut Along Dotted Line



Align to OEM blower
motor mounting hole



Align to OEM blower
motor mounting hole



Cut Along Dotted Line





www.vintageair.com

Packing List: Evaporator Kit (551967)

No.	Qty.	Part No.	Description
1.	1	765200	Gen 5 Magnum Max Module with 404 ECU
2.	1	781967	Accessory Kit

Checked By: _____
 Packed By: _____
 Date: _____

1



Gen 5 Magnum Max
Module with 404 ECU
765200

2

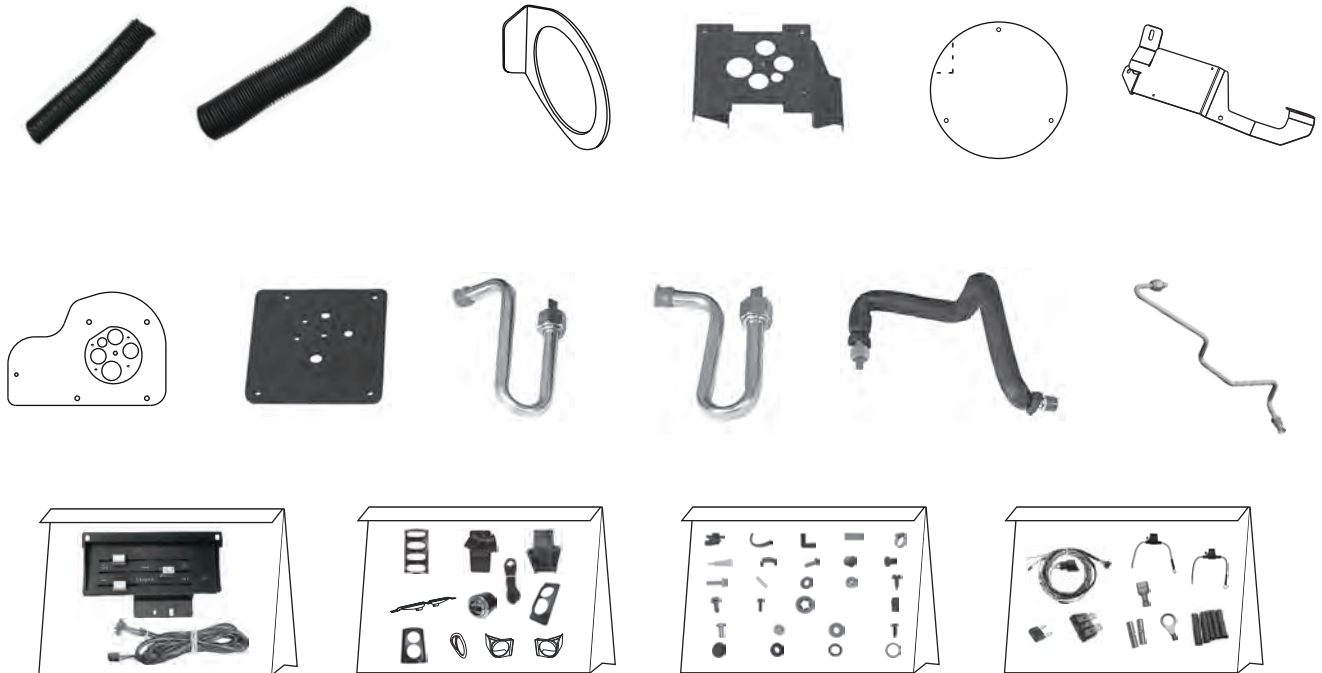

Accessory Kit
781967

**NOTE: Images may not depict actual parts and quantities.
 Refer to packing list for actual parts and quantities.**